

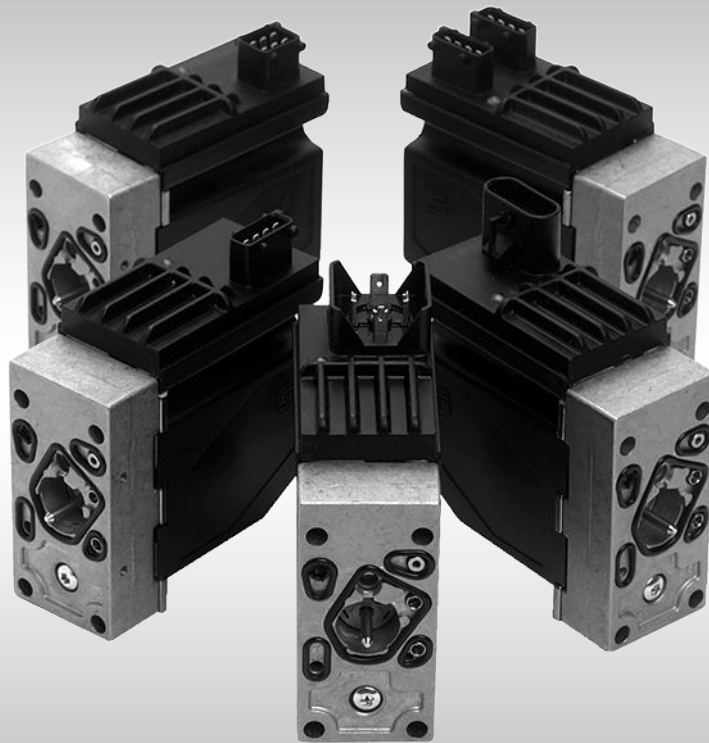

Service Manual
Electrohydraulic Actuators
PVE and PVHC



Revision history*Table of revisions*

Date	Changed	Rev
Apr 2014	Converted to Danfoss layout – DITA CMS	AB
May 2012		AA

Contents**Abbreviations Chart**

List of abbreviations for PVG/PVE.....	4
Danfoss Literature Reference.....	5

Warnings

PVE warnings.....	6
-------------------	---

General Information

Introduction.....	7
General instructions.....	7
Avoid injuries or material damage.....	7
Keep it clean.....	8
Replace all O-rings and gaskets.....	8
Safety precautions.....	8
PVG with the PVE overview.....	8
Trouble shooting.....	9
Hydraulic variants.....	11

Exchanging PVE or PVHC

Before replacing or dismantling a PVE or PVHC.....	13
Dismounting of PVE / PVHC.....	14
Mounting of Replacement.....	14
Test and use of PVG and Actuator.....	15
Returning Replaced Actuator for Customer Claims.....	15
Important note for digital actuators.....	15
Parameter transfer.....	15
Before disconnecting the failing PVED-CC from the system.....	15
After mounting the new PVED-CC on the PVG	15

Abbreviations Chart

List of abbreviations for PVG/PVE

Abbreviation	Description
ASIC	Application Specific Integrated Circuit - the part of the PVE where spool position is controlled to follow setpoint
ATEX	Certificated for use in explosive environment
AVC	Auxillary Valve Comand - ISOBUS/J1939 standard signal for valve control
AVCTO	Auxillary Valve Comand Time Out - Fault monitoring setting
AVEF	Auxillary Valve Estimated Flow - ISOBUS/J1939 standard signal for valve feedback
CAN	Controller Area Network - Communication method used by PVED
CLC	Closed Loop Circuit
CRC	Cyclic Redundancy Check - Method for ensuring validity of data.
-DI	PVE with Direction Indication
DM1	Diagnostic Message 1 - J1939 message informing about present fault
DM2	Diagnostic Message 2 - J1939 message informing about fault history
DM3	Diagnostic Message 3 - J1939 message clearing fault history
DSM	Device State Machine. Deterministic description of system process
ECU	Electronic Control Unit
EH	Electro Hydraulic
-F	PVE for Float spool. Two variants: 4 pin with float at 75%. 6 pin with separate float.
FMEA	Failure Mode Effect Analysis
ISOBUS	Communication standard for CAN
J1939	Communication standard for CAN
LED	Light Emitting Diode
LS	Load Sensing
LVDT	Linear Variable Differential Transducer - Position sensor
NC	Normally Closed solenoid valve in PVE
NC-H	Normally Closed standard solenoid valve in PVEH
NC-S	Normally Closed solenoid valve Super in PVES
NO	Normally Open solenoid valve in PVE
PLC	Programmable Logical Circuit
PLUS+1®	Trademark for Danfoss controllers and programming tool
POST	Power On Self Test. Boot up evaluation for PVED
Pp	Pilot Pressure. The oil gallery for PVE actuation
PVB	Proportional Valve Basic module - valve slice
PVBS	Proportional Valve Basic module Spool
PVBZ	Proportional Valve Basic module Zero leakage
PVE	Proportional Valve Electric actuator
PVEA	PVE variant with 2-6 % hysteresis
PVED	PVE variant Digital controlled via CAN communication
PVEH	PVE variant with 4-9% Hysteresis
PVEM	PVE variant with 25-35% hysteresis
PVEO	PVE variant with ON/OFF actuation

Abbreviations Chart

Abbreviation	Description
PVEP	PVE variant PWM controled
PVES	PVE variant with 0-2% hysteresis
PVEU	PVE variant with US 0-10V
PVG	Proportional multi-section Valve Group
PVHC	PV variant with High Current controlled valve actuator
PVM	Proportional Valve Manual control with handle
PVP	Proportional Valve Pump side module.Inlet
PVS	Proportional Valve end plate
PVSK	Proportional Valve end plate crane. Inlet module with Spool Control
PWM	Pulse Width Modulation
S4 DJ	Series 4 Digital J1939 service tool software for PVED-CC
SAE	Society Automotive Engineering
-R	PVE with Ramp function
-NP	PVE with solenoid disable in Neutral Position
-SP	PVE with Spool Position feedback
uC	Micro-controller
uCSM	Micro-controller State Machine
U _{DC}	Power supply Direct Current; also called V _{bat} for battery voltage
U _S	Steering voltage for the PVE control; also called V _S

Danfoss Literature Reference

Danfoss literature reference for PVG and PVE products

Title	Type	Order number
PVG 32 Proportional Valve Groups	Service Manual	11039167
PVG 100 Proportional Valve Groups	Service Manual	11048807
PVG 32 Proportional Valve Groups	Technical Information	520L0344
PVG 100 Proportional Valve Groups	Technical Information	520L0720
PVG 120 Proportional Valve Groups	Technical Information	520L0356
PVE Series 4 for PVG 32, PVG 100 and PVG 120	Technical Information	520L0553
PVED-CC Electro Hydraulic actuator	Technical Information	520L0665
PVED-CX Electro Hydraulic actuator	Technical Information	11070179
PVG 32 Metric ports	Technical Information	11051935

Warnings**PVE warnings** **Warning**

Not applying to the Operational Conditions can compromise safety.

All brands and all types of directional control valves – including proportional valves – can fail and cause serious damage. It is therefore important to analyze all aspects of the application. Because the proportional valves are used in many different operation conditions and applications, the machine builder/ system integrator alone is responsible for making the final selection of the products – and assuring that all performance, safety and Warning requirements of the application are met.

A PVG with PVE can only perform according to description if conditions in this Technical Information are met.

In particularly exposed applications, protection in the form of a shield is recommended.

When the PVE is in fault mode the quality of performance and validity of feedback is limited depending on the fault type.

Error pins from more PVEs may not be connected. Inactive error pins are connected to ground and will disable any active signal. Error pins are signal pins and can only supply very limited power consumption.

Deviation from recommended torque when mounting parts can harm performance and module.

Adjustment of the position transducer (LVDT) will influence calibration, and thereby also safety and performance.

When replacing the PVE, the electrical and the hydraulic systems must be turned off and the oil pressure released.

PVEA is not for use on PVG 100.

Hydraulic oil can cause both environmental damage and personal injury.

Module replacement can introduce contamination and errors to the system. It is important to keep the work area clean and components should be handled with care.

After replacement of modules or cables wiring quality must be verified by a performance test.

By actuation at voltage below nominal PVG will have reduced performance.

The PVE is not designed for use with voltage outside nominal.

Obstacles for the Pilot oil can have direct influence on spool control.

Reduced pilot oil pressure will limit spool control.

Too high pilot oil pressure can harm the PVE.

General Information

Introduction

This manual includes information for trouble shooting and servicing the PVE and PVHC PVG actuators. The actuators are used on PVG 32, PVG 100, PVG120 and some EH steerings. This manual does not cover the PVG in general nor any steering.

PVE actuators

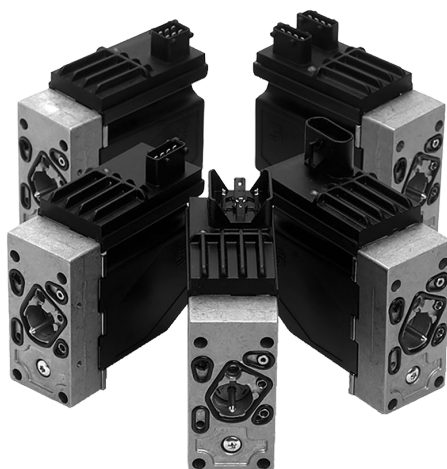

PVHC actuator

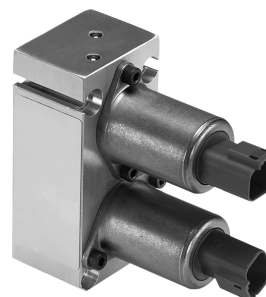

The PVE and PVHC for PVG 32 and PVG 100 are the same, for PVG 120 includes a special interface plate, has another LVDT-pin and allows larger spool travel. Service on the actuators is identical independent of valve size.

In general service on PVE and PVHC is limited to exchange of O-rings and connectors or whole actuator. For digital PVE, PVED-CC and PVED-CX service also can be parameter reading, parameter change and change of software.

Performing service, trouble shooting and repair may require removal of valve and valve parts from the application. This can easily introduce misplaced parts and contamination and thereby thread performance and safety. Following cleanliness requirements is a prerequisite for service.

For general description, specifications and operating parameters on PVG valves and actuators please see the relevant Technical Information listed in reference list. Danfoss technical literature is available on www.danfoss.com.

A worldwide network of Danfoss Global Service Partners is available for major repairs. Danfoss trains and certifies Global Service Partners on a regular basis. You can locate your nearest Global Service Partner using the distributor locator at www.danfoss.com.

⚠ Warning

Do not attempt to service PVG valves without build sheet specifications for reference.

General instructions

Follow these general procedures when servicing PVG 32 valves:

Avoid injuries or material damage



Plan the process thoroughly. Block wheels and other moving parts to prevent undesired movement. Secure against leakage of hydraulic fluid. Hydraulic fluid can cause contamination, cause burns due to temperature and other injuries due to high pressure. Follow all instructions from machine builder.

General Information

Keep it clean



Cleanliness is the primary mean of assuring long lifetime for the application. Clean the outside of the valve thoroughly before any disassembly. Cap ports and hoses when opening. Avoid contamination by both dirt and chemical agents. Clean parts using a clean solvent wash and air dry.

Replace all O-rings and gaskets



Danfoss recommends inspection of O-rings and gaskets and replacement if wear or contamination could be relevant. Dried out O-rings and gaskets must be replaced.

Safety precautions

Always consider safety precautions before beginning a service procedure. Protect yourself and others from injury. Follow instructions from machine manufacture carefully. Read and include the warnings from the relevant PVG literature in your work planing.



Warning

Ensure stable conditions

Manipulation on a mechanical, hydraulic and electrical system can potentially create dangerous situations. Please ensure that all necessary precautions are taken to prevent dangerous situations.



Warning

Release hydraulic pressure in system

Shut down pump and release pressure in all work functions, in tank and pilot pressure if not released by previous operations



Warning

Disengage electrical system

Disengage power supply and system control. If relevant for application, disengage system output e.g. error pin, direction indicator.

PVG with the PVE overview

The PVG is a sectional spool valve stack with up to 12 individually controlled proportional valves. The PVG with the PVE can be operated as single valves or several valves in cooperation. The oil flow out of the work section (A- or B-port) can be controlled by a combination of the following:

- PVE controlling the spool position using pilot oil pressure.
- A handle (PVM) in mechanical interface with the spool.

General Information

PVG 32 structural lay-out with naming

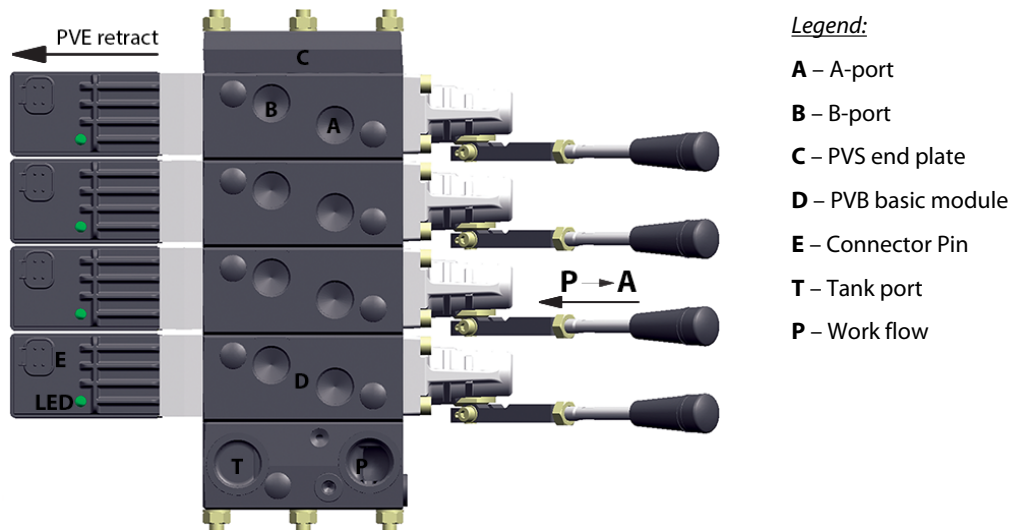

Valve section - standard mounted - seen from PVP with naming

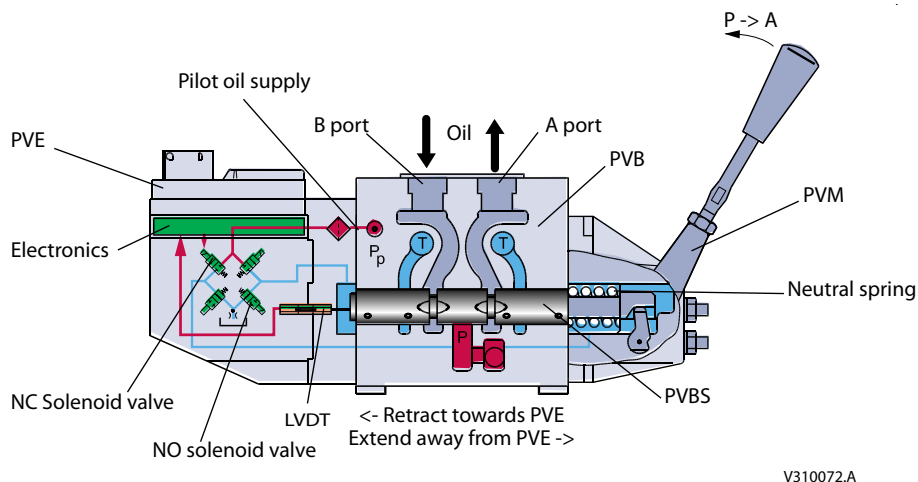

Oil out of A-port → PVM pushed towards PVB → retract → LVDT moves into PVE

Trouble shooting

The Service Manuals for PVG 32 and PVG 100 have a thoroughly description of system trouble shooting and parts trouble shooting. Please look for descriptions there before starting with the actuator. The actuator is an electrohydraulic subsystem used for moving the spool and thereby opens the valve for work flow.

General Information

All PVE variants, connector options: Deutsch, AMP and DIN/Hirschmann (PVEO and PVEO-R are without LVDT)

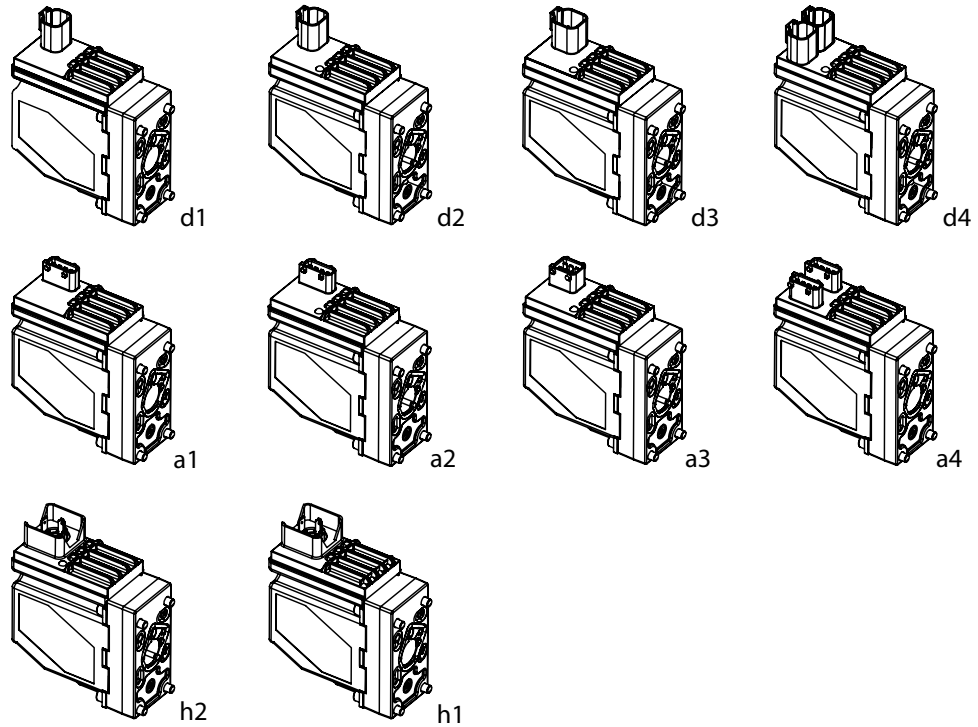

Principle for PVED/ PVEH/ PVEM/ PVEO/ PVEP/ PVES/ PVEU (PVEO is without LVDT)

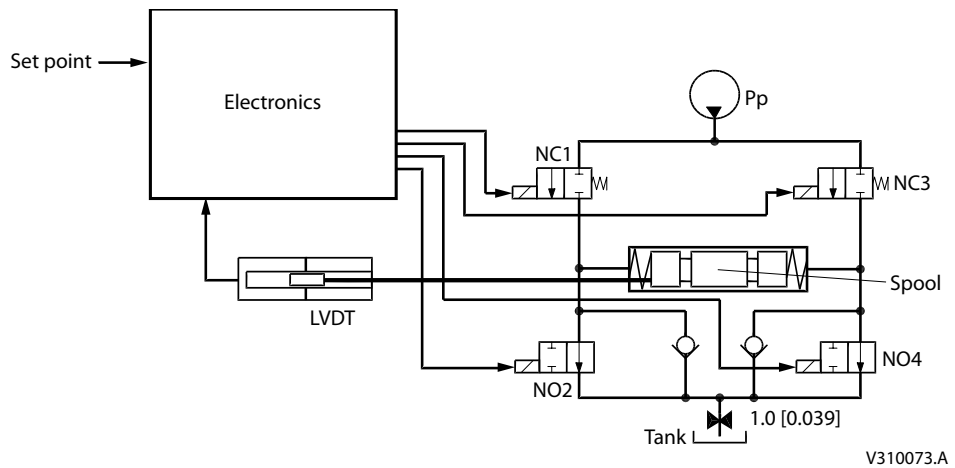

V310073.A

General Information

Hydraulic variants

Principle for PVEA

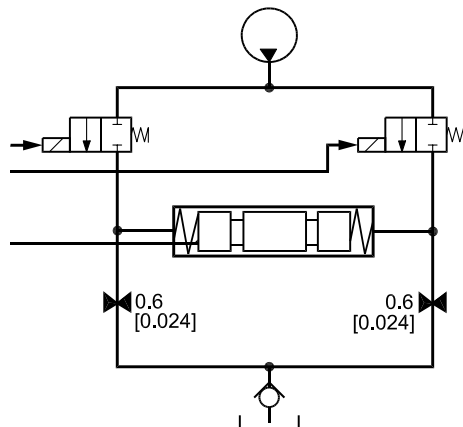

157-338

NO2 and NO4 are replaced with orifices.

Principle for PVE with ramp

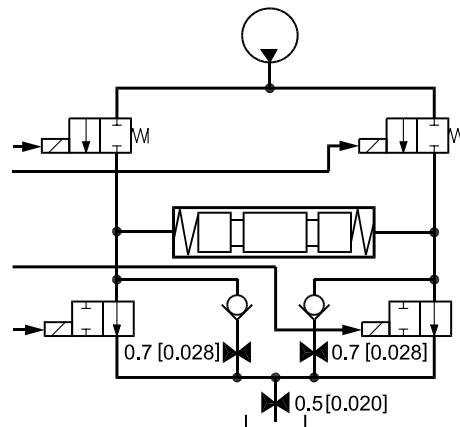

157-469

Tank orifice has smaller diameter.

Principle for PVHC

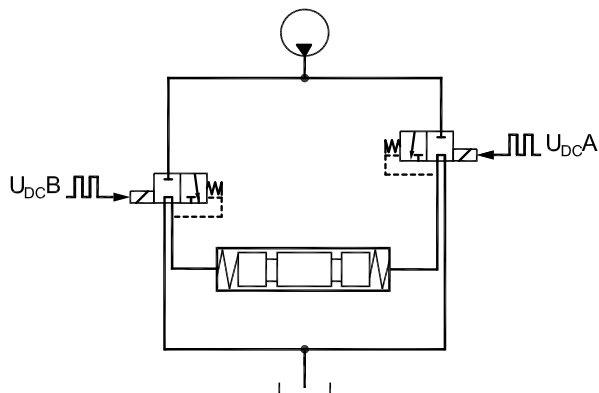

V310374.A

PVHC AMP

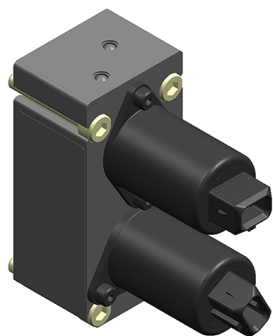

PVHC Deutsch

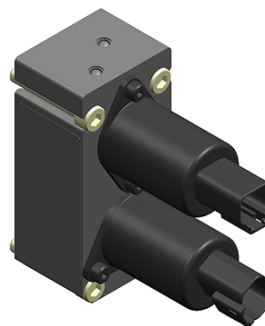

By warranty claim please verify and describe before replacing actuator.

General Information

- Function of external parts
 - Can spool move as expected when activated by PVM
 - Is pilot pressure available
 - Can control signal activate other PVE/PVHC
 - Is cabling undamaged
 - Are connectors dry and with sealing
- Function of PVE
 - Failure is temporary/continues
 - Failure is in one direction (A or B) or both
 - Visible damage

Exchanging PVE or PVHC

These guidelines are only meant to point out issues that could be related to the application, the PVG and its actuator. Danfoss can and will not give directives how work has to be planed and supervised.

Before replacing or dismantling a PVE or PVHC

1. Ensure that the actuator has to be dismantled. Follow the trouble shooting procedure to make sure that the failure is not elsewhere in the application. See Service Manual for PVG32 and PVG100.

Digital actuators contain parameters. These parameters must also be in the replacing PVED and must be backed up before removing the old PVED.
See description for parameter transfer for PVED later.

2. Clean surroundings on PVG for dirt and rust/oxidations; and do not use cleaning agents or methods that require higher IP than the actuator supports.

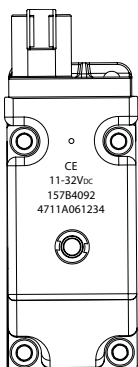

3. Have a clean area to put new PVE/PVHC before mounting.
4. Have a clean area to put old PVE/PVHC before eventually returning for investigation.
5. Have the right tools at hand.
6. Ensure that spare part is the correct actuator .
7. Unpack replacing actuator:
 - a) If actuator has LVDT avoid mishandling and bending of it
 - b) Ensure all O-rings are in place
 - c) Ensure new bolts are present
 - d) Ensure presence of eventually electrical connector sealing
 - e) Eventually clean off excessive oil with a soft tissue. PVE must still be coated with a thin oil film
 - f) Keep actuator protected from a pollution during the whole process. Keep in a bag.

Mounting of PVE variants

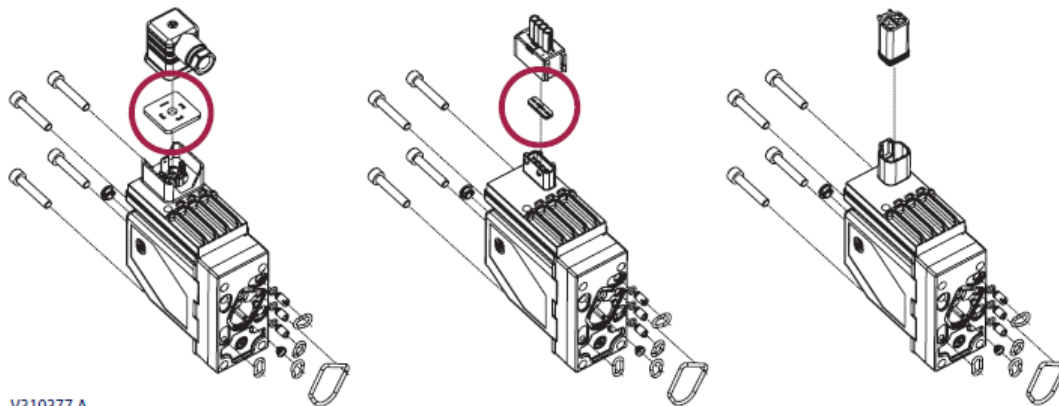

V310377.A

Exchanging PVE or PVHC

Dismounting of PVE / PVHC

1. Remove connector(s) from PVE:
 - a) Pull connector, not cable.
 - b) Verify if cable and connectors can be reused or must be replaced e.g. isolation, lock.
2. Loosen and unscrew bolts counter clockwise. Be aware of leaking oil.
3. Remove PVE/PVHC carefully:
 - a) Don't introduce pollution to PVB nor actuator. Marked areas are especial sensible to pollution "cover".
 - b) Ensure O-rings are removed with actuator.
 - c) Place removed actuator safe best in a bag.

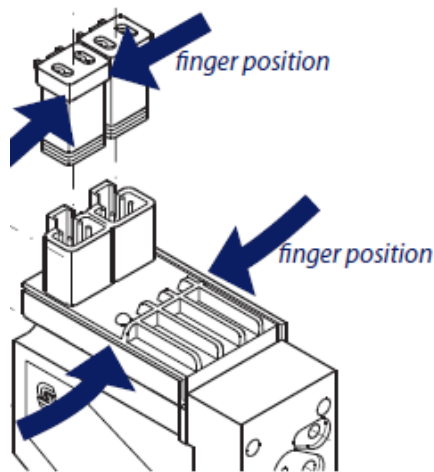

4. Eventually clean PVB carefully with a soft tissue to have clean interface for replacing actuator.

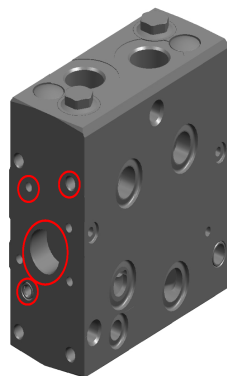

Mounting of Replacement

1. Avoid contamination - also oil in connectors.
2. Avoid harming LVDT pin.
3. Depending on PVB – actuator orientation place one or all bolts in actuator bolt holes.
4. Reassure that O-rings are in place on actuator.
5. Place actuator on PVB and screw bolts lose and clockwise.
6. Tighten bolts to torque indicated in instruction.
7. Connect wiring.

Exchanging PVE or PVHC

Test and use of PVG and Actuator

After replacement of actuator the system must be tested after manufactures guidelines.

After service the PVG must be tested according to manufactures guidelines. Ensure that safety functions and performance apply to demands.

Before restart bleed system. PVG can be bleed through PVM. Let application run for In worst cases air must be washed out by oil in up to 5 minutes activation.

Returning Replaced Actuator for Customer Claims

If replaced actuator is returned to Danfoss for analysis description of malfunction and application must be submitted too. See form in section "returning claims".

Important note for digital actuators

Before replacing a PVED-CC or a PVED-CX you must ensure to have the right parameters for the replacing module.

If you replace a PVED-CC with another PVED-CC without preset parameters and the application don't support automatic parameter setting you must upload the relevant data to your PC before exchanging and then download them to the new PVED-CC.

To perform this, you need:

- PVED-CC PLUS+1® S4 DJ Service Tool. Available for free on www.danfoss.com.
- CG150 CAN bus interface
- Service cable

Follow the instructions following the download of the service tool to have the tool installed.

Parameter transfer

Before disconnecting the failing PVED-CC from the system

1. Start the PVED-CC PLUS+1 S4 DJ service tool, connect to the CAN bus (PVED-CC) and turn on power.
2. Select the ID for the PVED-CC that must be exchanged.
3. Go to OEM Data screen:
 - a) Upload parameters from ECU (F2)
 - b) Save to file. Use unique name.
4. Go to Spool Data screen:
 - a) Upload parameters from ECU (F2)
 - b) Save to file. Use unique name.
5. Go to Process Data screen:
 - a) Upload parameters from ECU (F2)
 - b) Save to file. Use unique name.
6. Disconnect the PVED-CC from the CAN bus.

After mounting the new PVED-CC on the PVG

1. Connect to the PVED-CC to the CAN bus (turn on power).
2. In the service tool Scan the connected system (F8)
3. Select Node ID 128 (assuming you are using a standard spare part PVED-CC)
4. Go to the Process Data Screen. Press align to file:
 - a) Choose the Process Data file just saved.
 - b) Align to 128.

Exchanging PVE or PVHC

- c) Press Load file to Service tool. Choose the Process Data file just saved.
- d) Download parameters to ECU (F2).
- 5.** Go to the Spool Data Screen. Press align to file:
 - a) Choose the Spool Data file just saved.
 - b) Align to 128.
 - c) Press Load file to Service tool. Choose the Spool Data file just saved.
 - d) Download parameters to ECU (F2).
- 6.** Go to the OEM Data Screen. Press align to file:
 - a) Choose the OEM Data file just saved
 - b) Align to 128
 - c) Press Load file to Service tool. Choose the OEM Data file just saved
 - d) Download parameters to ECU (F2)
- 7.** Reboot PVED-CC
- 8.** In the service tool Scan the connected system (F8)
- 9.** Select the ID for the PVED-CC that was exchanged
- 10.** Go to the Process Data Screen
- 11.** Verify that data are like they were initially before exchange
- 12.** Go to the Spool Data Screen
- 13.** Verify that data are like they were initially before exchange
- 14.** Go to the OEM Data Screen
- 15.** Verify that data are like they were initially before exchange



Products we offer:

- Bent Axis Motors
- Closed Circuit Axial Piston Pumps and Motors
- Displays
- Electrohydraulic Power Steering
- Electrohydraulics
- Hydraulic Power Steering
- Integrated Systems
- Joysticks and Control Handles
- Microcontrollers and Software
- Open Circuit Axial Piston Pumps
- Orbital Motors
- PLUS+1® GUIDE
- Proportional Valves
- Sensors
- Steering
- Transit Mixer Drives

Danfoss Power Solutions is a global manufacturer and supplier of high-quality hydraulic and electronic components. We specialize in providing state-of-the-art technology and solutions that excel in the harsh operating conditions of the mobile off-highway market. Building on our extensive applications expertise, we work closely with our customers to ensure exceptional performance for a broad range of off-highway vehicles.

We help OEMs around the world speed up system development, reduce costs and bring vehicles to market faster.

Danfoss – Your Strongest Partner in Mobile Hydraulics.

Go to www.powersolutions.danfoss.com for further product information.

Wherever off-highway vehicles are at work, so is Danfoss.

We offer expert worldwide support for our customers, ensuring the best possible solutions for outstanding performance. And with an extensive network of Global Service Partners, we also provide comprehensive global service for all of our components.

Please contact the Danfoss Power Solution representative nearest you.

Comatrol

www.comatrol.com

Schwarzmueller-Inverter

www.schwarzmueller-inverter.com

Turolla

www.turollaocg.com

Valmova

www.valmova.com

Hydro-Gear

www.hydro-gear.com

Daikin-Sauer-Danfoss

www.daikin-sauer-danfoss.com

Local address:

Danfoss Power Solutions US Company
2800 East 13th Street
Ames, IA 50010, USA
Phone: +1 515 239 6000

Danfoss Power Solutions GmbH & Co. OHG
Krokamp 35
D-24539 Neumünster, Germany
Phone: +49 4321 871 0

Danfoss Power Solutions ApS
Nordborgvej 81
DK-6430 Nordborg, Denmark
Phone: +45 7488 2222

Danfoss Power Solutions (Shanghai) Co., Ltd.
Building #22, No. 1000 Jin Hai Rd
Jin Qiao, Pudong New District
Shanghai, China 201206
Phone: +86 21 3418 5200

Danfoss can accept no responsibility for possible errors in catalogues, brochures and other printed material. Danfoss reserves the right to alter its products without notice. This also applies to products already on order provided that such alterations can be made without changes being necessary in specifications already agreed.. All trademarks in this material are property of the respective companies. Danfoss and the Danfoss logotype are trademarks of Danfoss A/S. All rights reserved.