

Technical Information

# Electrohydraulic Actuators PVE, Series 4 and PVHC

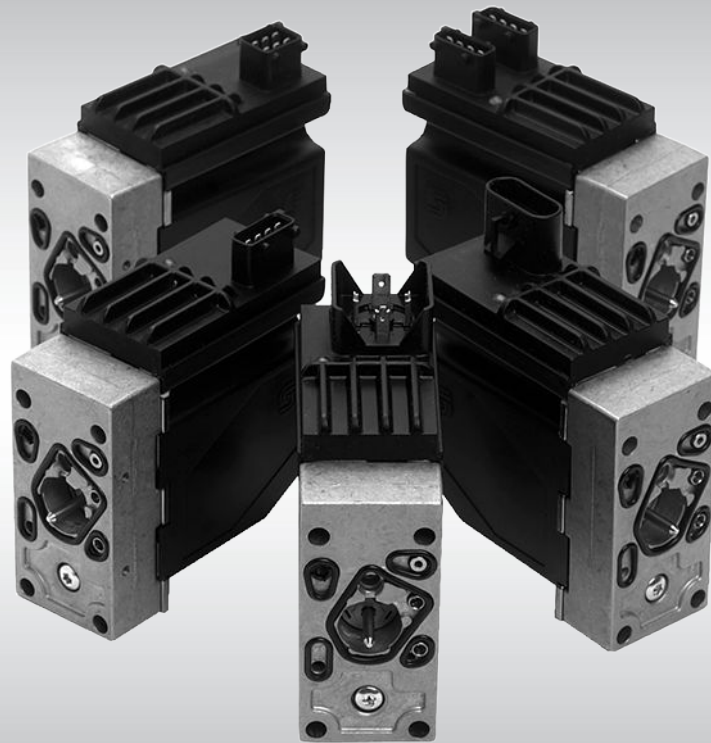

**Revision history***Table of revisions*

<b>Date</b>	<b>Changed</b>	<b>Rev</b>
February 2015	Oil consumption corrected	GE
January 2014	Converted to Danfoss layout – DITA CMS	GD
March 2013	Back page matter change	GC
August 2012	Various changes, new articles about NP	GB
May 2012	Major update	GA

**Contents**
**General Information**

List of abbreviations for PVG/PVE.....	5
Literature reference for PVG products.....	6
Standards for PVE.....	7
PVE with connector variants.....	7
Warnings.....	7
PVE series 4 introduction.....	7
PVE stands for PVE actuator .....	8
PVG with the PVE overview.....	9

**Functionality**

PVG functionality.....	10
PVE functionality.....	10
Hydraulic subsystems.....	10
Variant of hydraulic subsystem: PVEA.....	11
Variant of hydraulic subsystem: PVE with ramp.....	12
Variant of hydraulic subsystem: PVHC.....	12
Mechanical subsystem.....	13
Electronic subsystem.....	14

**Safety and monitoring**

Fault monitoring and reaction.....	15
Active fault reaction is activated after 500 ms of error (PVEA: 750 ms). .....	15
Passive fault reaction is activated after 250 ms of error (PVEA: 750 ms).....	15
The solenoid valves are disabled when:.....	16
Spool position feedback (-SP).....	16
Direction indication feedback (-DI).....	17
Solenoid disabling function (-NP).....	18

**Safety in application**

Control system example.....	20
Examples of wiring block diagram.....	22

**PVE control**

PVE control by voltage.....	24
PLUS+1 <sup>®</sup> Compliant.....	25
ATEX PVE.....	25
PVEU–PVE with fixed control signal range.....	25
PVE controlled with PWM signal.....	25
PVEP.....	26
PVEO.....	27
PVE ON/OFF activation.....	27
PVE for float spool.....	27
There are two variants of float spool PVBS.....	27
PVHC control.....	30
PVE hysteresis.....	30
Example of PVE use.....	31

**Technical Data**

PVE operating parameters .....	33
PVHC control specification.....	34
PVEO and PVEM control specification.....	35
PVEA, PVEH, PVES and PVEU control specification .....	35
PVEP control specification.....	36
PVE dimensions for PVG 32 and PVG 100.....	37
PVE dimensions for PVG 120.....	38
PVEO pinout.....	40
PVEO connection.....	40
PVE standard connection data / pinout .....	41
PVE standard connections.....	42
Standard PVE with DI.....	42

**Contents**

Standard PVE with SP.....	43
Standard PVE with NP.....	43
PVHC connection.....	43
PVE with separate float pin.....	44
PVEP with controlled PWM.....	44

**PVE warnings**

PVE warnings.....	46
-------------------	----

**PVE code numbers**

PVE code numbers for PVG 32 and PVG 100 use.....	47
PVE code numbers for use on PVG 120.....	48
PVE accessories.....	49
Connector code numbers at other suppliers .....	50
PVED-CC code numbers for use on PVG 32 and PVG 100.....	50

**General Information**
**List of abbreviations for PVG/PVE**

Abbreviation	Description
ASIC	Application Specific Integrated Circuit - the part of the PVE where spool position is controled to follow setpoint
ATEX	Certificated for use in explosive environment
AVC	Auxillary Valve Comand - ISOBUS/J1939 standard signal for valve control
AVCTO	Auxillary Valve Comand Time Out - Fault monitoring setting
AVEF	Auxillary Valve Estimated Flow - ISOBUS/J1939 standard signal for valve feedback
CAN	Controller Area Network - Communication method used by PVED
CLC	Closed Loop Circuit
CRC	Cyclic Redundancy Check - Method for ensuring validity of data.
-DI	PVE with Direction Indication
DM1	Diagnostic Message 1 - J1939 message informing about present fault
DM2	Diagnostic Message 2 - J1939 message informing about fault history
DM3	Diagnostic Message 3 - J1939 message clearing fault history
DSM	Device State Machine. Deterministic description of system process
ECU	Electronic Control Unit
EH	Electrohydraulic
-F	PVE for Float spool. Two variants: 4 pin with float at 75%. 6 pin with separate float.
FMEA	Failure Mode Effect Analysis
ISOBUS	Communication standard for CAN
J1939	Communication standard for CAN
LED	Light Emitting Diode
LS	Load Sensing
LVDT	Linear Variable Differential Transducer - Position sensor
NC	Normally Closed solenoid valve in PVE
NC-H	Normally Closed standard solenoid valve in PVEH
NC-S	Normally Closed solenoid valve Super in PVES
NO	Normally Open solenoid valve in PVE
PLC	Programmable Logical Circuit
PLUS+1®	Trademark for Danfoss controllers and programming tool
POST	Power On Self Test. Boot up evaluation for PVED
Pp	Pilot Pressure. The oil gallery for PVE actuation
PVB	Proportional Valve Basic module - valve slice
PVBS	Proportional Valve Basic module Spool
PVBZ	Proportional Valve Basic module Zero leakage
PVE	Proportional Valve Electric actuator
PVEA	PVE variant with 2-6 % hysteresis
PVED	PVE variant Digital controlled via CAN communication
PVEH	PVE variant with 4-9% Hysteresis
PVEM	PVE variant with 25-35% hysteresis
PVEO	PVE variant with ON/OFF actuation
PVEP	PVE variant PWM controled
PVES	PVE variant with 0-2% hysteresis
PVEU	PVE variant with US 0-10V
PVG	Proportional multi-section Valve Group

**General Information**

Abbreviation	Description
PVHC	PV variant with High Current controlled valve actuator
PVM	Proportional Valve Manual control with handle
PVP	Proportional Valve Pump side module.Inlet
PVS	Proportional Valve end plate
PVSK	Proportional Valve end plate crane. Inlet module with Spool Control
PWM	Pulse Width Modulation
S4 DJ	Series 4 Digital J1939 service tool software for PVED-CC
SAE	Society Automotive Engineering
-R	PVE with Ramp function
-NP	PVE with solenoid disable in Neutral Position
-SP	PVE with Spool Position feedback
uC	Microcontroller
uCSM	Microcontroller State Machine
U <sub>DC</sub>	Power supply Direct Current; also called V <sub>bat</sub> for battery voltage
U <sub>S</sub>	Steering voltage for the PVE control; also called V <sub>S</sub>

**Literature reference for PVG products**
*Literature reference*

Literature title	Type	Order number
PVG 32 Proportional valve group	Technical Information	520L0344
PVG 100 Proportional valve group	Technical Information	520L0720
PVG 120 Proportional valve group	Technical Information	520L0356
PVG 32 Metric ports	Technical Information	11051935
PVE series 4	Technical Information	520L0553
PVED-CC Electro-hydraulic actuator	Technical Information	520L0665
PVED-CX Electro-hydraulic actuator	Technical Information	11070179
Basic module for PVBZ	Technical Information	520L0721
PVSK module with integrated diverter valve and P-disconnect function	Technical Information	520L0556
PVPV / PVPM pump side module	Technical Information	520L0222
Combination module PVGI	Technical Information	520L0405
PVSP/M Priority module	Technical Information	520L0291
Hitch Control	System Description User Manual	11036124 11033753
PVBZ	Data sheet	520L0681
PVBZ-HS	Data sheet	520L0956
PVBZ-HD	Data sheet	11035599
MC024-010 and MC024-012 Controllers	Data sheet	520L0712

**General Information**
**Standards for PVE**

- International Organization for Standardization ISO 13766 Earth moving machinery - *Electromagnetic compatibility*.
- EN 50014:1997 +A1, A2: 1999
- EN 50028: 1987. For ATEX approved PVE
  - IEC EN 61508
  - ISO 12100-1 / 14121
  - EN 13849 (Safety related requirements for control systems)
  - Machinery Directive 2006/42/EC" (1<sup>st</sup> Edition December 2009)

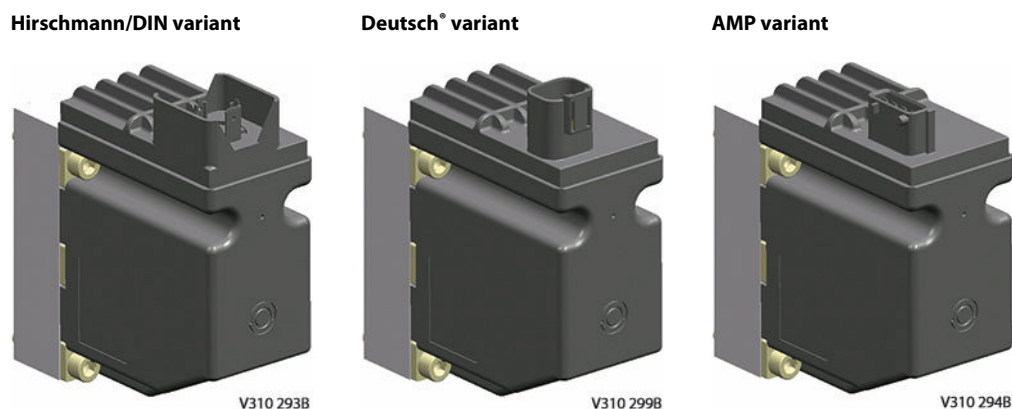
**PVE with connector variants**

**Warnings**

Please work through all warnings before implementing actuators in any application. The list of warnings must not be seen as a full list of potential dangers. Depending on application and use other potential dangers can occur.

Warnings are listed next to the most relevant section and repeated in a special section at the end of technical data. See [Product warnings](#) for more information.

** Warning**

---

All brands and all types of directional control valves – including proportional valves – can fail and cause serious damage. It is therefore important to analyze all aspects of the application. Because the proportional valves are used in many different operation conditions and applications, the machine builder/ system integrator alone is responsible for making the final selection of the products – and assuring that all performance, safety and warning requirements of the application are met.

---

**PVE series 4 introduction**

PVE Series 4 is the common name for the Danfoss PVG electrical actuator. This technical information covers our voltage controlled PVE and our current controlled PVHC actuator. For the PVHC please see in the PVHC section. The digital actuators PVED-CC and PVED-CX are covered in their special technical information.

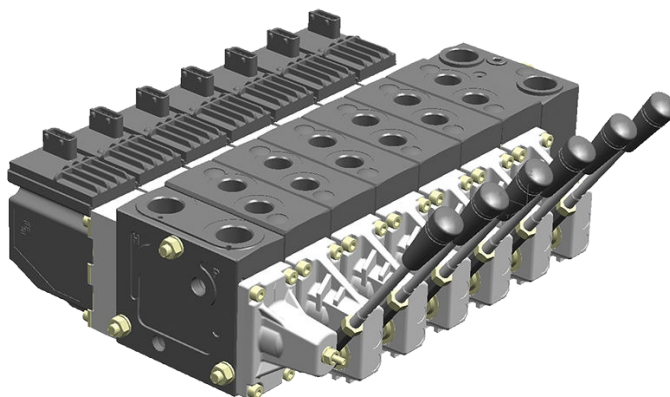
**General Information**
*PVE controlled PVG with PVSK*

**PVE stands for PVE actuator**

The Danfoss PVE is built on more than thirty years experience of electrical valve control and is the perfect fit for our high performance proportional valves PVG 32, PVG 100 and PVG 120, as it is for our EH steering.

All our products are developed in close cooperation with system manufacturers from the mobile hydraulic market. That is the reason for our high performance in all market segments

The PVE can be controlled from a switch, a joystick, a PLC, a computer or a Danfoss PLUS+1<sup>®</sup> microcontroller. The PVE is available in multiple variants. A short list here just gives the main variations.

*Available PVE variants*

Actuation	On/Off
	Proportional - Closed loop controlled
	Proportional - Direct control
Control signal	Voltage
	PWM
	Current (PVHC)
Precision	Standard precision
	High precision
	Super high precision
Feedback	Spool position
	Direction indicator
	Error
	None
Connectors	Deutsch <sup>®</sup>
	AMP
	DIN/Hirschmann
Fault detection and reaction	Active
	Passive
	None
Power supply	11 V – 32 V multi-voltage
	12 V
	24 V



**General Information**

**PVG with the PVE overview**

The PVG is a sectional spool valve stack with up to 12 individually controlled proportional valves. The PVG with the PVE can be operated as single valves or several valves in cooperation. The oil flow out of the work section (A- or B-port) can be controlled by a combination of the following:

- PVE controlling the spool position using pilot oil pressure.
- A handle (PVM) in mechanical interface with the spool.

*PVG 32 structural lay-out with naming*

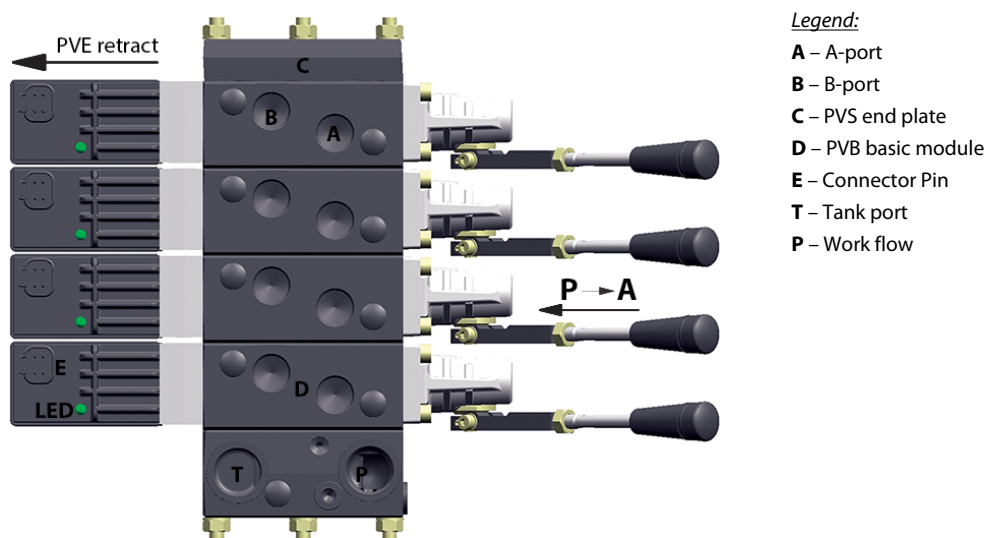

*Valve section - standard mounted - seen from PVP with naming*

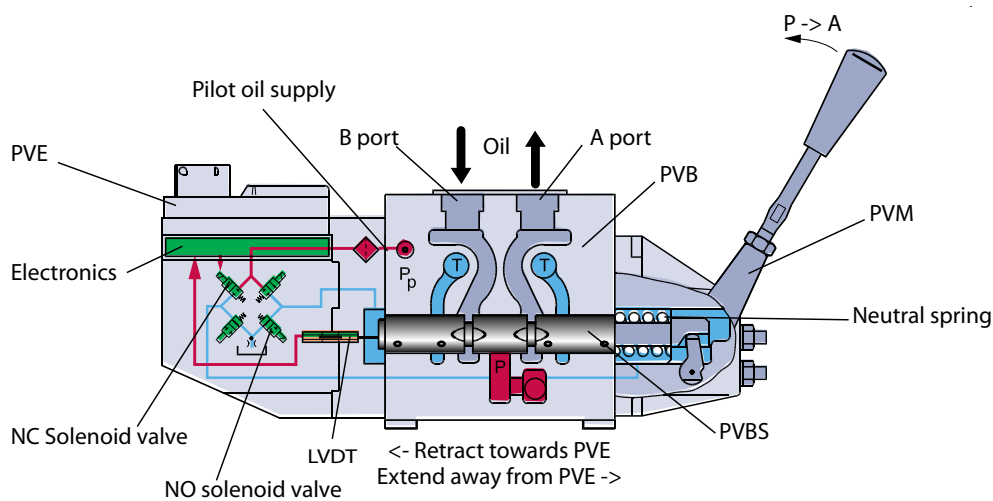

V310072.A

Oil out of A-port → PVM pushed towards PVB → retract → LVDT moves into PVE

**Functionality**
**PVG functionality**

The PVG valve distributes oil from pump flow to a particular work function in the application via a specific valve section. This is done by moving the spool (PVBS).

Depending on the choice of components the oil work flow enters the PVG through the PVP (proportional valve pump side module), a PVSK, a mid inlet or other system interface and enters the PVB (proportional valve basic module) via the P gallery and leaves through the T gallery.

The PVP/PVSK also supplies the Pilot oil pressure (Pp) for the PVE to activate the spool (PVBS). Special designed float spools also allow oil flow in both directions between A- and B-port not opening to pump nor tank.

When looking at the figure you see the valve section from PVP towards PVS with the PVM and PVE standard mounted. When PVM and PVE are interchanged it's called option mounted.

*Valve section with naming - standard mounted - seen from PVP*

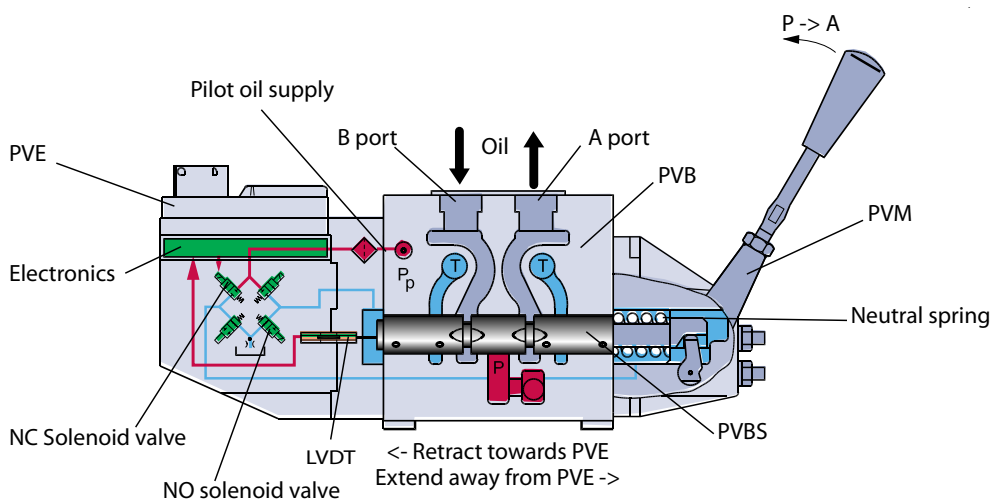

V310072.A

**Oil out of A-port = PVM pushed towards PVB = retract = LVDT moves into PVE.**

With the spool in neutral, default position when held by the neutral spring, the connection to the application via ports is blocked. Moving the PVBS towards the PVE, as in the figure, opens a connection between P and A and also between B and T. This is done by either pushing the PVM or activating the PVE. The PVE moves the PVBS by letting Pilot Oil Pressure (Pp) push on the right end of the PVBS and releasing pressure from the left end. For details on PVG 32 please see *PVG 32 Proportional Valve Groups, Technical Information, 520L0334*.

**PVE functionality**

This section has focus on how the PVE works and interacts. The description here is general and variant specific descriptions will all refer to this.

The PVE is an electro mechanical device, meaning that functionality is depending on mechanical, hydraulic, electrical and control conditions given by PVE, PVG, application and vehicle. The result of this is that implementing operation and safety conditions also must include vehicle specific considerations.

**Hydraulic subsystems**

The hydraulic subsystem is used for moving the spool and thereby open the valve for work flow.

Functionality

Pilot oil diagram

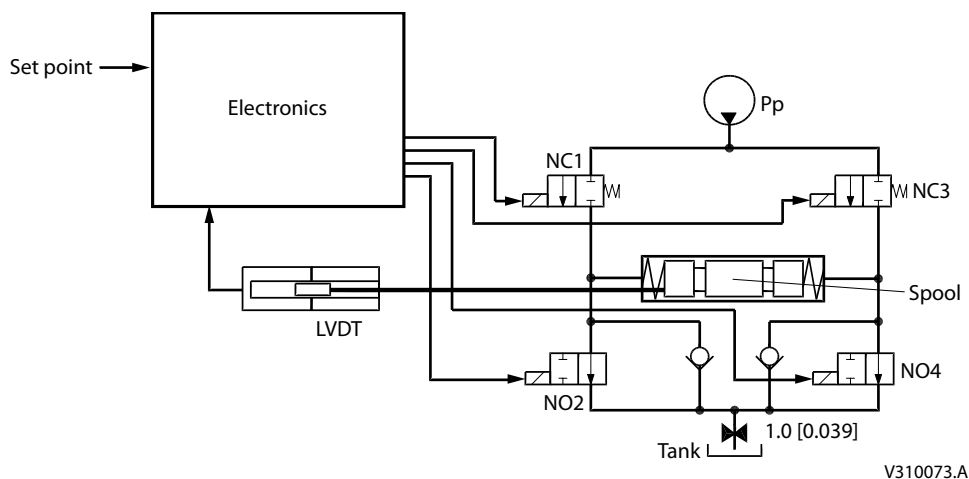

The hydraulic subsystem moves the spool and thereby opens the valve for work flow. The heart in the hydraulic subsystem is the solenoid valve bridge which controls the Pilot Pressure (Pp) on spool ends. It consist of four poppet valves, the two upper are normally closed (NC) and the two lower are normally open (NO).

The Pp will work against the PVBS neutral spring when the spool is moved out of blocked (neutral) and together with the spring when going in blocked. This combined with a larger opening in the NO than in the NC will give a faster movement towards blocked than out of blocked.

When the PVE is powered the solenoids are all put in closed state. To move the PVBS to the right NC1 and NO4 are opened and NC3 and NO2 are kept closed.

The activation of the solenoid valves represents oil consumption and thereby also a pressure drop in the pilot oil gallery. By simultaneous use of multiple PVE the Pp can fall and result in performance problems.

The two check valves next to the NO are anti-cavitation valves. The orifice to tank reduces tank pressure spikes and can also be used for ramp function.

**Warning**

Obstacles for the Pilot oil pressure (Pp) can have direct influence on spool control. Reduced Pp will limit spool control. Too high Pp can harm the PVE.

**Variant of hydraulic subsystem: PVEA**

Hydraulic variant: PVEA

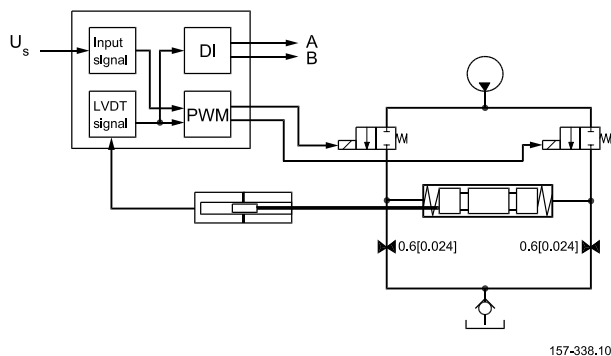

Functionality

NO2 and NO4 are replaced with orifices.

**Warning**

PVEA is not for use on PVG 100.

**Variant of hydraulic subsystem: PVE with ramp**

Hydraulic subsystem variant: PVE with ramp

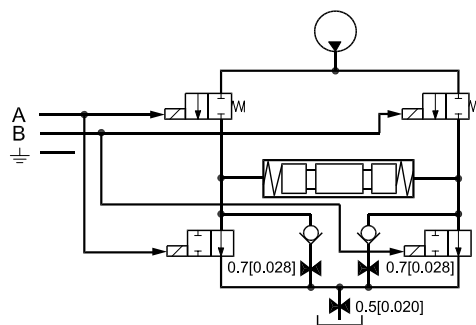

157-469.10

Tank orifice has smaller diameter.

With electrical proportional actuation, the main spool position is adjusted so that its position corresponds to an electrical control signal.

The control signal is converted into a hydraulic pressure signal that moves the main spool in the PVG. This is done by means of two proportional pressure-reducing valves. The electrical actuator can be controlled either by a current amplifier card, or directly from a programmable microcontroller.

For more information see these technical informations:

- PVG 32 Proportional Valve Groups **520L0344**,
- PVG 100 Proportional Valve Groups **520L0720** and
- PVG 120 Proportional Valve Groups **520L0356**.

**Variant of hydraulic subsystem: PVHC**

The PVHC does not work as a PVE and does not have transducer, anti cavitation nor protection against tank pressure spikes. It is necessary to use the PVHC in combination with 25 bar [362.6 psi] pilot pressure, and standard FC spools fitted for hydraulic actuation. Because of the 25 bar pilot pressure, it is not possible to combine PVHC with PVE on a PVG.

**Functionality**

Hydraulic subsystem variant: PVHC

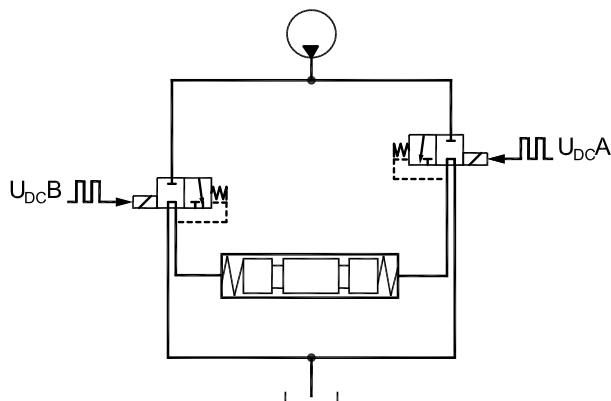

V310374.A

With electrical proportional actuation, the main spool position is adjusted so that its position corresponds to an electrical control signal. The control signal is converted into a hydraulic pressure signal that moves the main spool in the PVG. This is done by means of two proportional pressure-reducing valves. The electrical actuator can be controlled either by a current amplifier card, or directly from a programmable microcontroller.

For more information see these technical informations:

- PVG 32 Proportional Valve Groups **520L0344**,
- PVG 100 Proportional Valve Groups **520L0720** and
- PVG 120 Proportional Valve Groups **520L0356**.

**Mechanical subsystem**

The mechanical subsystem gives interface to valve and control system and provides protection to hydraulic and electrical/electronic subsystem. The LVDT, not used on all variants, gives feed back to electronics on spool position. The LVDT is calibrated in production and recalibration should only be done in special cases. The standard PVE has an aluminum block for distributing pilot oil. PVE with anodized block are available.

The connector gives the electrical interface to power and control system. Danfoss have a variety of connectors. We know that tradition and the aspects of serviceability are important when our customers choose. We have chosen the Deutsch connector as our main solution. The quality of wiring has direct influence on water integrity and signal quality therefore disturbance or changes in cabling can influence safety and performance.

PVE connectors: Hirschmann/DIN, AMP and Deutsch

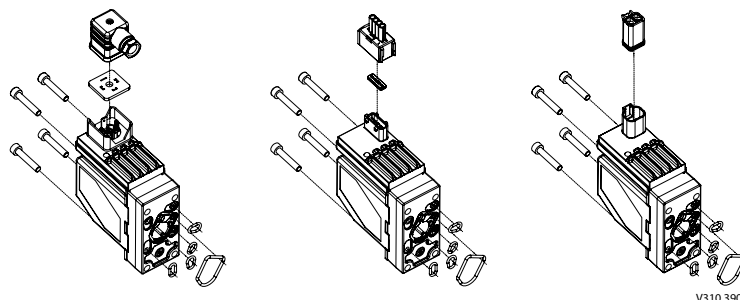

V310 390B

## Functionality

### Electronic subsystem

The PVE (A/ H/ M/ S/ U) control signal is a low current voltage, a PWM can also be used. The PVEP has build-in a PWM evaluation and cannot be controlled by proportional voltage. The control signal is referred to as  $U_5$ .

*Function blocks for electronics*

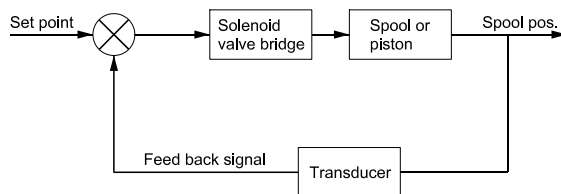

157-503.10

The PVE features Closed Loop Control (CLC). This is made possible by on board electronics and an integrated feedback transducer that measures spool movement. The integrated electronics compensate for flow forces on the spool, internal leakage, changes in oil viscosity, pilot pressure, etc. This results in lower hysteresis and better resolution.

In principle the set-point determines the level of pilot pressure which moves the main spool. The position of the main spool is sensed in the LVDT which generates an electric feed-back signal registered by the electronics. The variation between the set-point signal and feed-back signal actuates the solenoid valves. The solenoid valves are actuated so that hydraulic pilot pressure drives the main spool into the correct position.

The **LVDT (Linear Variable Differential Transducer)** is an inductive transducer with very high resolution. When the LVDT is moved by the main spool a voltage is induced proportional to the spool position. The use of LVDT gives contact-free connection between mechanics and electronics. This means an extra long lifetime and no limitation as regards the type of hydraulic fluid used.

The PVEO and PVHC do not have embedded control electronics and do not support closed loop control.

## Safety and monitoring

The choice of PVE also decides the level of feedback and safety. PVE are available with fault monitoring, spool direction indication, spool position feedback and separate float control.

The fault monitoring is available in PVEA/H/S/P/U and is a utilization of the ASIC.

Direction Indication is available in PVEO/A/H and they are dual powered PVE where separate pins give an active feedback for spool movement.

Spool position is available in PVES and is a precise feedback on a separate pin for actual spool position.

The separate float control is a protection against unintended float activation.

---

The PVEM, PVEO and PVHC do not have fault monitoring.

---

## Fault monitoring and reaction

The fault monitoring system is available in two versions:

- Active fault monitoring provides a warning signal and deactivates the solenoid valves. A reboot of the PVE is required to reactivate.
- Passive fault monitoring provides a warning signal only. A reboot is not required.

Both active and passive fault monitoring systems are triggered by the same four main events:

### 1. Control signal monitoring

The Control signal voltage (US) is continuously monitored. The permissible range is between 15% and 85% of the supply voltage. Outside this range the section will switch into an error state. A disconnected US pin (floating) is recognized as neutral set point.

### 2. Transducer supervision

The internal LVDT wires are monitored. If the signals are interrupted or short-circuited, the PVE will switch into an error state.

### 3. Supervision of spool position

The actual position must always correspond to the demanded position ( $U_S$ ). If the actual spool position is further out from neutral than the demanded spool position ( $>12\%$ , PVEA:  $>25\%$ ) or in opposite direction, the PVE will switch into an error state. With neutral/blocked setpoint the tolerance is  $\pm 0,5$  mm relative the calibrated neutral position. Spool position closer to neutral and in same direction will not cause an error state. The situation is considered "in control".

### 4. Float monitoring

Float must be entered or left within a time limit. On the six pin float PVE too high delay will cause an error state. The float Time Outs has own thresholds. Only relevant for the six pin PVEH-F.

### Active fault reaction is activated after 500 ms of error (PVEA: 750 ms).

- The solenoid valve bridge is disabled and the PVBS is released to spring control
- The error pin is powered\*
- The LED change color
- The state is memorized and continues until PVE reboot

### Passive fault reaction is activated after 250 ms of error (PVEA: 750 ms)

- The solenoid valve bridge is NOT disabled and the PVBS is NOT released
- The error pin is powered ( for PVE with direction indication both DI pins goes low by fault.)
- The LED change color
- The state is active for minimum 100 ms and is reset when error disappears

**Safety and monitoring**
 **Warning**

Error pins from more PVEs may not be interconnected. Not activated error pins are connected to ground and will disable any active signal. Error pins are signal pins and can only supply very limited power consumption.

To avoid the electronics in undefined state a general supervision of power supply ( $U_{DC}$ ) and internal clock frequency is implemented. This function applies to PVEA, PVEH, PVEP, PVES and PVEU independently of fault monitoring version and PVEM - and will not activate fault monitoring.

**The solenoid valves are disabled when:**

- the supply voltage exceeds 36 V
- the supply voltage falls below 8.5 V
- the internal clock frequency fails

*PVE fault monitoring overview*

PVE type	Fault monitoring	Delay before error out	Error mode	Error output status	Fault output on PVE <sup>1)</sup>	LED light	Memory (reset needed)
PVEO PVEM PVHC	No fault monitoring	-	-	-	-	-	-
PVEA PVEH PVEP PVES PVEU	Active	500 ms (PVEA: 750 ms)	No fault	Low	< 2 V	Green	-
			Input signal faults	High	$\sim U_{DC}$	Flashing red	Yes
			Transducer (LVDT)			Constant red	
			Close loop fault				
	Passive	250 ms (PVEA: 750 ms)	No fault	Low	< 2 V	Green	-
			Input signal faults	High	$\sim U_{DC}$	Flashing red	No
			Transducer (LVDT)			Constant red	
			Close loop fault				
PVE Float six pin	Active	500 ms	Float not active	High	$\sim U_{DC}$	Constant red	Yes
		750 ms	Float still active				

<sup>1)</sup> Measured between fault output pin and ground.

 **Warning**

It's up to the customer to decide on the required degree of safety for the system.

For PVE with direction indication:

- both DI pins go low when error is active.
- when  $U_{DC1}$  is disabled,  $U_S$  is not monitored and defined as 50%.

**Spool position feedback (-SP)**

The -SP functionality is a 0.5 V to 4.5 V feedback, inverted in direction relative to  $U_S$  with 2.5 V as neutral value.

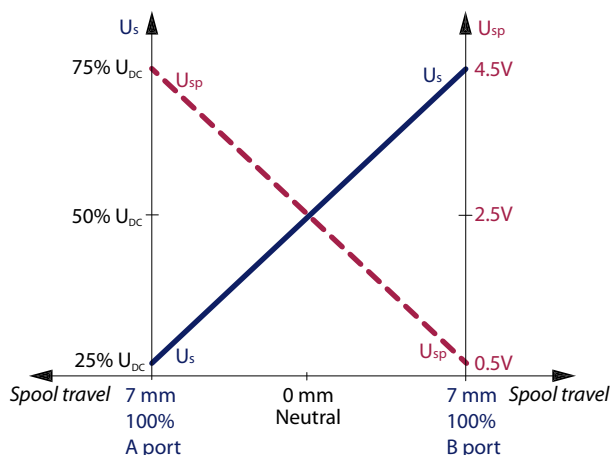

**Safety and monitoring**
*Spool position feedback (-SP)*

**Direction indication feedback (-DI)**

PVE with build in indication for spool movement direction are available.

The PVE-DI has dual power supply.  $U_{DC1}$  only supplies solenoid valves.  $U_{DC2}$  supplies electronics and feed back. The PVE does not work without  $U_{DC2}$ . DI-A and DI-B are relative standard mounting. The input signal fault monitoring is disabled if  $U_{DC1}$  is disabled. DI-A and DI-B are relative standard mounting.

The DI has two direction feedback signals with output high (close to  $U_{DC}$ ) when the spool is in neutral position. If the spool moves out of neutral position, the direction signal switches to low ( $< 0.2 V$ ). One of the signals goes low by spool  $\sim 0.8$  mm out of neutral and high by spool within  $0.4$  mm out of neutral.

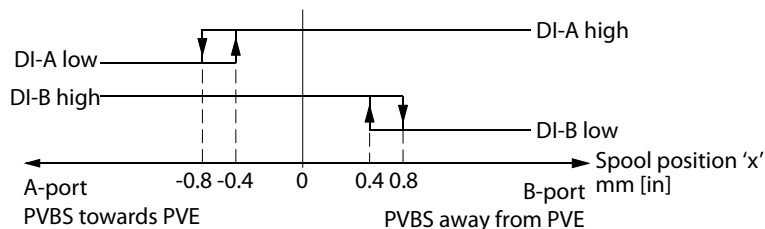
**Both direction indication signals go low when the error indicator goes high.**

*Direction indication feedback*

157-435.10

As shown in the figure, both "DI-A" and "DI-B" signals are "High" when the spool is in neutral position. When the spool is moving in the A direction, the "DI-A" signal goes "Low" and the "DI-B" signal stays "High". The reverse is true when the spool is moved in the B direction.

*Values for both Direction Indicators, pin A and pin B*

Transition to low from high	$0.8 \pm 1$ mm [0.031 in]
Transition to high from low	$0.4 \pm 1$ mm [0.015 in]
Transition to low both pins	error pin goes high
Maximum load of "DI-A", "DI-B"	50 mA
Voltage DI high by load 20 mA	$> U_{DC} - 1.5 V$
Voltage DI high by load 50 mA	$> U_{DC} - 2.0 V$
Voltage DI low	$< 0.2 V$

**Safety and monitoring**
**Solenoid disabling function (-NP)**

PVEH-NP and PVEA-NP have a build in feature that disables the solenoids by US at 50% and gives a feedback on the solenoid status. This is done to facilitate application monitoring. The fault monitoring is still activated but the closed loop will remain passive until the control signal shifts.

US disable range		48 % $U_{DC}$ to 52 % $U_{DC}$
Solenoid disable reaction time	From active to passive	750 ms <-> 1000 ms
	From passive to active	0 ms <-> 50 ms
Solenoid feedback signal	Maximum load	50 mA
	Voltage if solenoid active by load 20 mA	$> U_{DC} - 1.5 V$
	Voltage if solenoid active by load 50 mA	$> U_{DC} - 2.0 V$
	Voltage if solenoid passive	$< 1 V$

PVEH-F (six pin) has also the disable function but not the feedback. Our general recommendation is disabling of PVE that are not in active use.

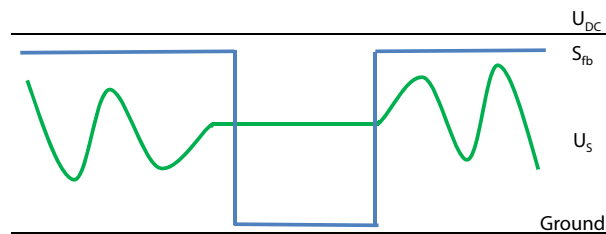
*Solenoid disabling function (-NP) curves*

## Safety in application

All makes and all types of control valves (incl. proportional valves) can fail, thus the necessary protection against the serious consequences of function failure should always be built into the system. For each application an assessment should be made for the consequences of pressure failure and uncontrolled or blocked movements.

To determine the degree of protection that is required to be built into the application, system tools such as an FMEA (Failure Mode and Effect Analysis) and Hazard and Risk Analysis can be used.

### **FMEA – IEC EN 61508**

FMEA (Failure Mode and Effect Analysis) is a tool used for analyzing potential risks. This analytical technique is utilized to define, identify, and prioritize the elimination or reduction of known and/or potential failures from a given system before it is released for production. Please refer to IEC FMEA Standard 61508.

### **Hazard and risk analysis ISO 12100-1 / 14121**

This analysis is a tool used in new applications as it will indicate whether there are special safety considerations to be met according to the machine directives EN 13849. Dependent on the determined levels conformity this analysis will determine if any extra requirements for the product design, development process, production process or maintenance, i.e. the complete product life cycle.

### **Warning**

---

All makes/brands and types of directional control valves – inclusive proportional valves – can fail and cause serious damage. It is therefore important to analyze all aspects of the application.

Because the proportional valves are used in many different operation conditions and applications, the manufacturer of the application is alone responsible for making the final selection of the products – and assuring that all performance, safety and warning requirements of the application are met.

The process of choosing the control system – and safety levels – is governed by the machine directives EN 13849 (Safety related requirements for control systems).

---

**Safety in application**

**Control system example**

*Example of a control system for manlift using PVE Fault monitoring input signals and signals from external sensors to ensure the PLUS+1® main controllers correct function of the manlift.*

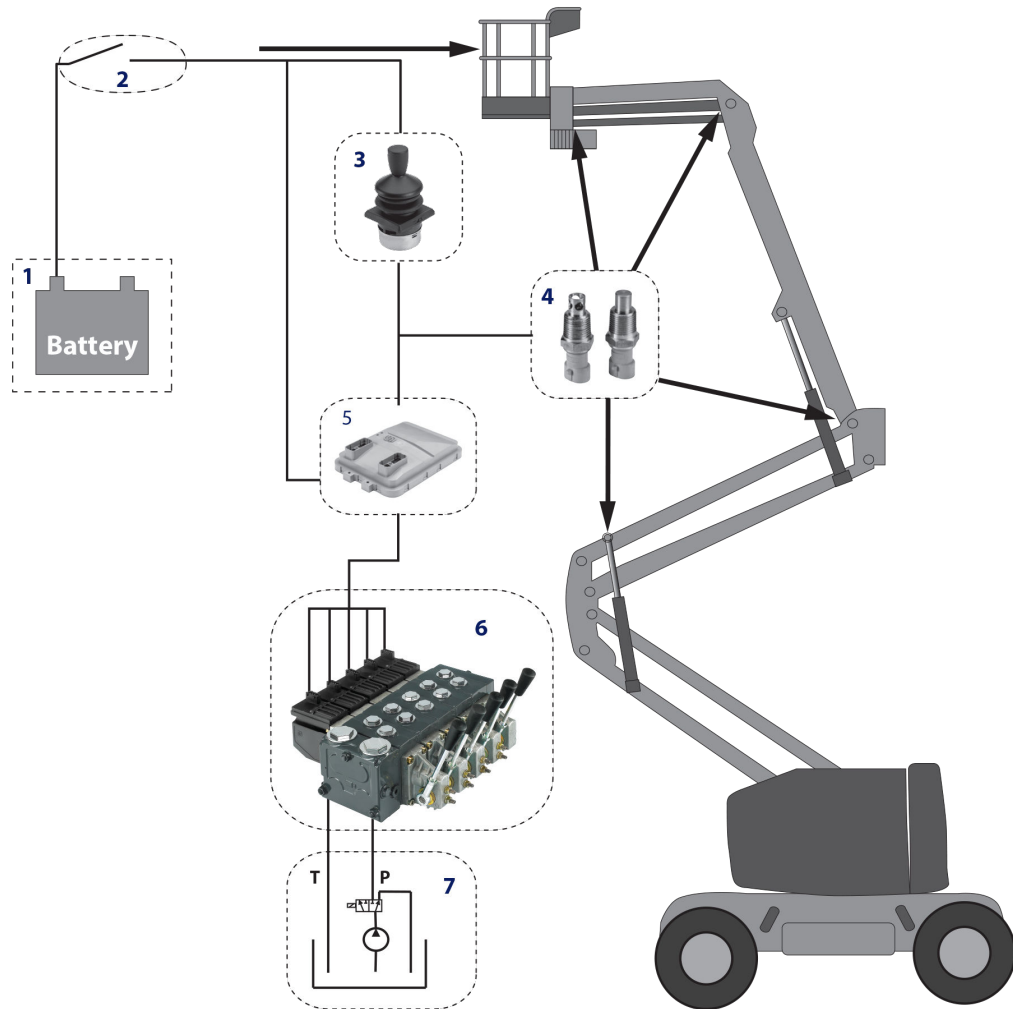

Legend:

- 1 – Main power supply
- 2 – Emergency stop/man present switch
- 3 – HMI/Joystick control
- 4 – Movement detection sensors
- 5 – Main controller
- 6 – PVG control valve
- 7 – Hydraulic deactivation

**Safety in application**

*Electrical block diagram for the above illustration*

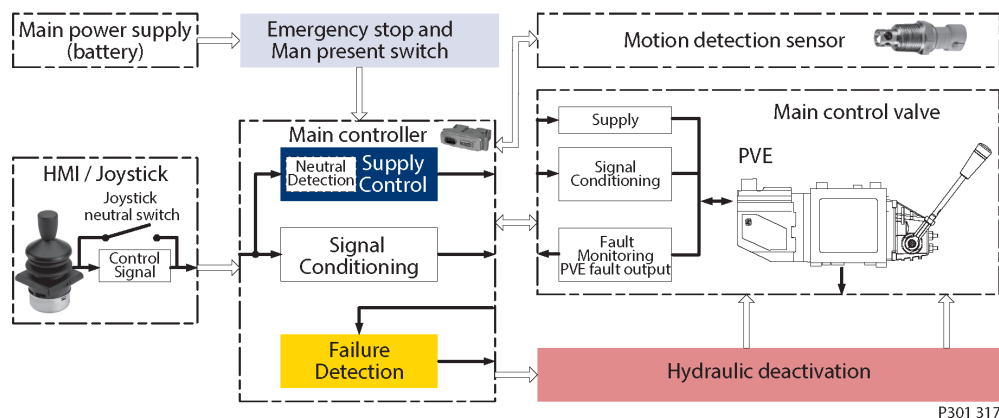

**⚠ Warning**

It is the responsibility of the equipment manufacturer that the control system incorporated in the machine is declared as being in conformity with the relevant machine directives.

**PVG 32 – mainly used in system with fixed displacement pumps:**

- PVSK, commonly used in crane application - full flow dump
- PVPX, LS dump to tank

**PVG 100 – alternative LS dump or pilot supply disconnect:**

- PVPP, pilot oil supply shut off
- External cartridge valve connecting LS pressure or main pressure to tank

**PVG 120 – pump disconnect / block for variable pumps:**

- PVPE, full flow dump for the PVG 120
- External cartridge valve connecting LS pressure to tank

Safety in application

Examples of wiring block diagram

Example of a typical wiring block diagram using PVEH with neutral power off switch and fault monitoring output for hydraulic deactivation.

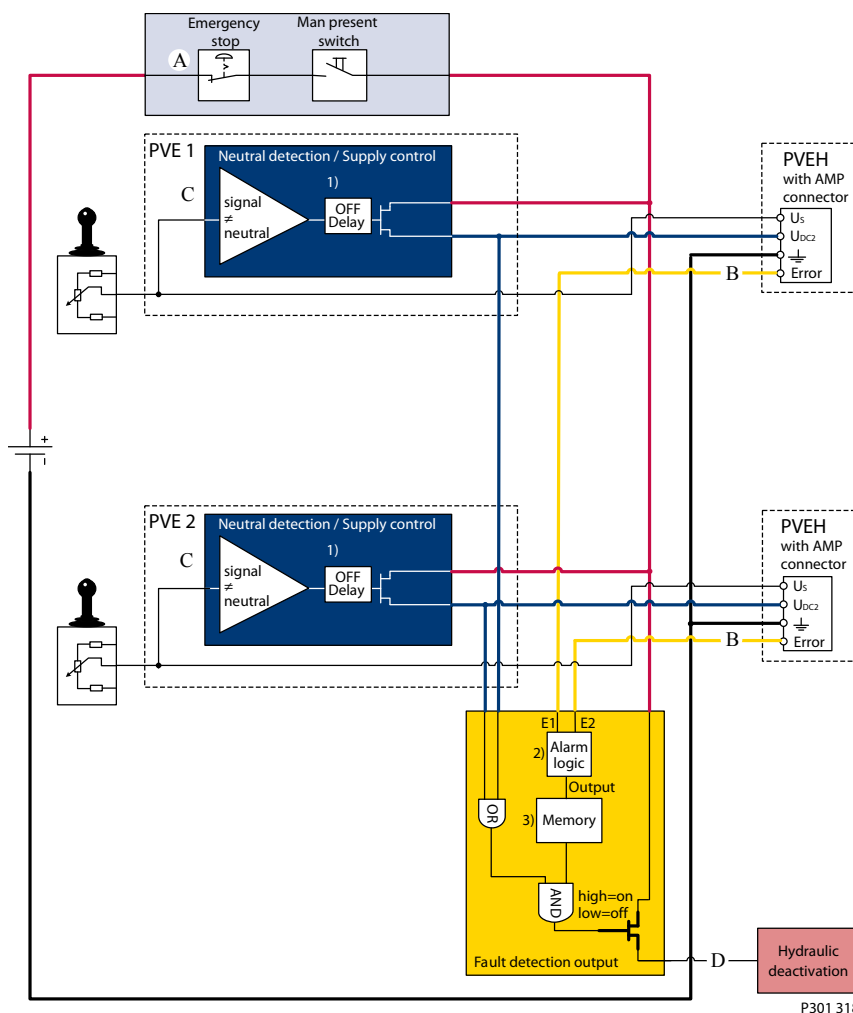

A– Emergency stop / man present switch

B– PVE Fault monitoring signals

C– Neutral signal detection.

D– Hydraulic deactivation

System Control Logic e.g. PLUS+1® for signal monitoring and triggering signal for deactivation of the hydraulic system.

**Warning**

It is the responsibility of the equipment manufacturer that the control system incorporated in the machine is declared as being in conformity with the relevant machine directives.

Safety in application

Example of fault monitoring for deactivation of the hydraulic system with extra fault inputs using the PVE's with DI (Direction Indication) function.

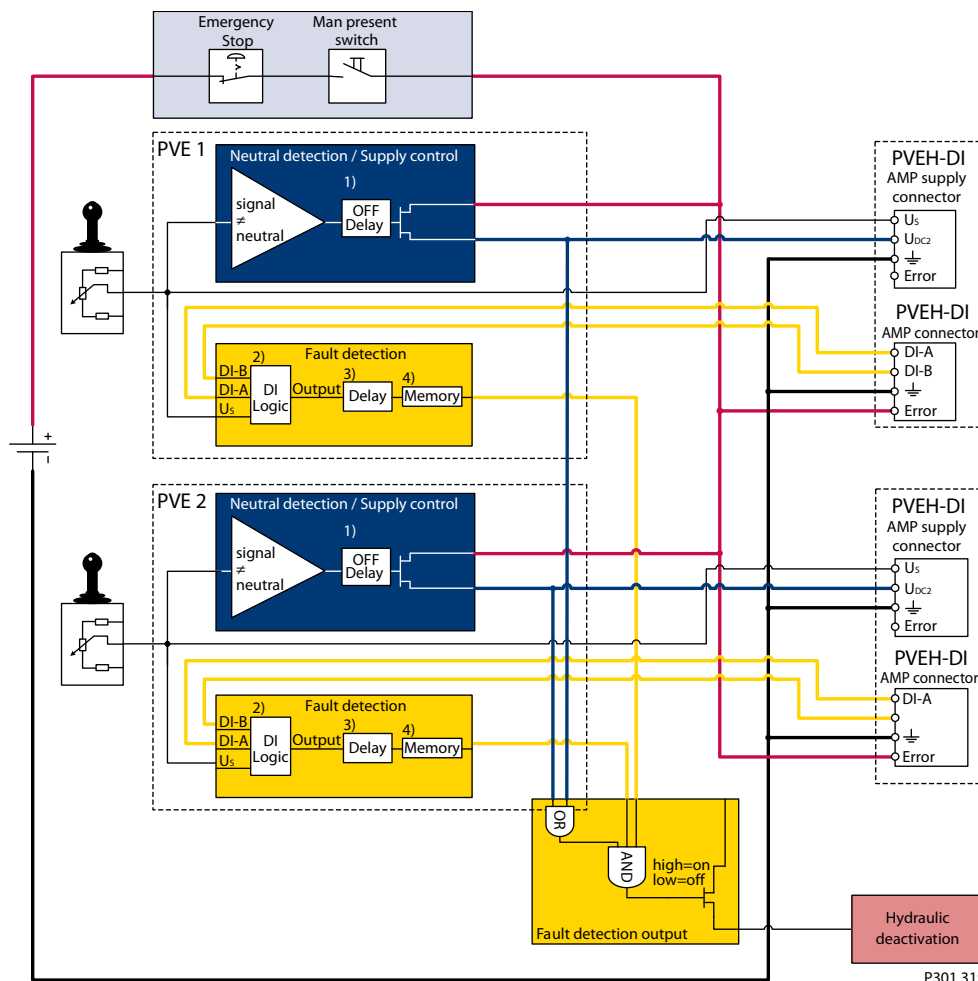

System Control Logic e.g. PLUS+1® for signal monitoring and triggering signal for deactivation of the hydraulic system.

**Warning**

It is the responsibility of the equipment manufacturer that the control system incorporated in the machine is declared as being in conformity with the relevant machine directives.

PVE control

PVE control by voltage

- The PVE is controlled with a low current voltage signal.
- The spool stroke is proportional to the control voltage ( $U_S$ ).
- The power is supplied via the supply wire ( $U_{BAT}$  or  $U_{DC}$ ).
- The ratio  $U_S/U_{DC}$  defines the actuation. For PVEU a defined voltage.
- A not connected  $U_S$  pin (floating) is recognized as  $U_S = \frac{1}{2} U_{DC}$ .

PVE characteristic – control by voltage

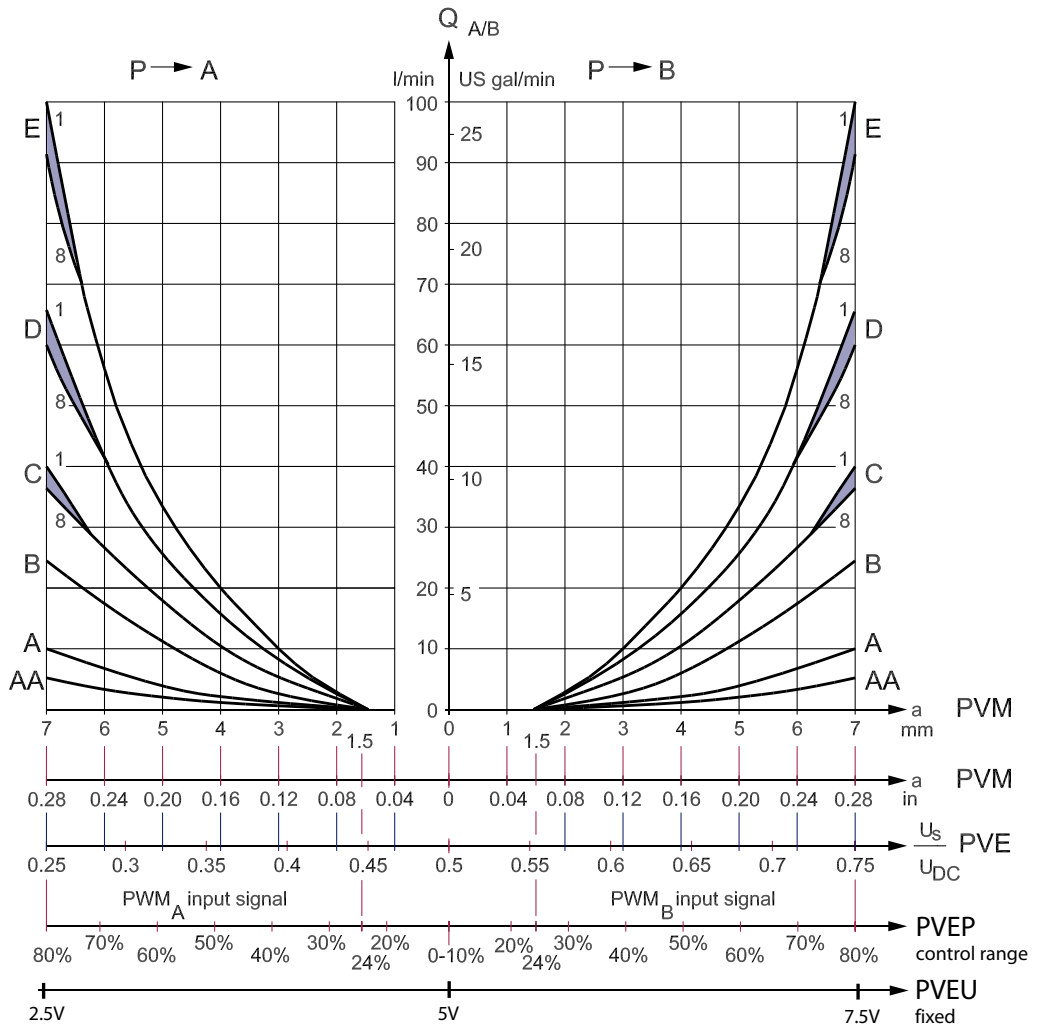

Values for standard mounted PVE (PVEA/M/H/S)

Function	Signal voltage ( $U_S$ )
Neutral	$U_S = 0.5 \cdot U_{DC}$
Q: P $\rightarrow$ A	$U_S = (0.5 \rightarrow 0.25) \cdot U_{DC}$
Q: P $\rightarrow$ B	$U_S = (0.5 \rightarrow 0.75) \cdot U_{DC}$



**PVE control**
**PLUS+1° Compliant**

PVEA, PVEH, PVES, PVEO, PVEP and PVED can be controlled by PLUS+1°

The  $U_{DC}$  has a capacitance of 2.2  $\mu$ F which can give problems with some micro-controller power supply. Danfoss has designed a special resistance supply and control cable to eliminate this problem.

**Warning**

PVEM is not PLUS+1° Compliant.

**ATEX PVE**

The Danfoss PVE ATEX portfolio has the same monitoring and control characteristics as the equivalent standard PVE.

**PVEU–PVE with fixed control signal range**

The PVEU (PVE 0-10V) is designed for PLC/ microcontroller(uC) control hence the U. The control signal  $U_s$  is fixed 0 V to 10 V independent of supply voltage  $U_{DC}$ .

*Signal voltage - PVEU*

Function	Signal voltage PVEU
Neutral	5 V
Q: P → A	5 V → 2,5 V
Q: P → B	5 V → 7,5 V

**PVE controlled with PWM signal**

The standard PVE, PVEA/M/H/S, can also be controlled by a pulse with modulated PWM signal.

The V1 and V2 for PWM must be symmetrically located around  $U_{DC2}$  and  $V1 \leq U_{DC}$ .

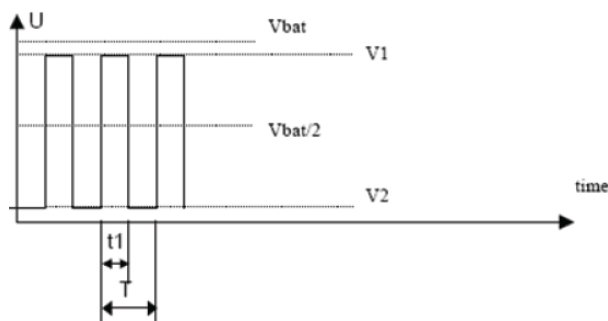

*Duty cycles for PVEA/PVEM/PVEH/PVES/PVEU*

Function	Duty cycle (dc) for PVEA/PVEM/PVEH/PVES/PVEU
Neutral	50% dc
Q: P → A	50% dc → 25% dc
Q: P → B	50% dc → 75% dc

*Recommended PWM frequency for PVE*

PVE type	PWM frequency
PVEM	> 200 Hz
PVEA/H/S/U	> 1 kHz

PVE control

**Warning**

The PWM is not evaluated by the PVE so variance/failure in period (T) will not be detected.

**PVEP**

The PVEP is designed for PWM control signals only.

*PVEP schematic and characteristic*

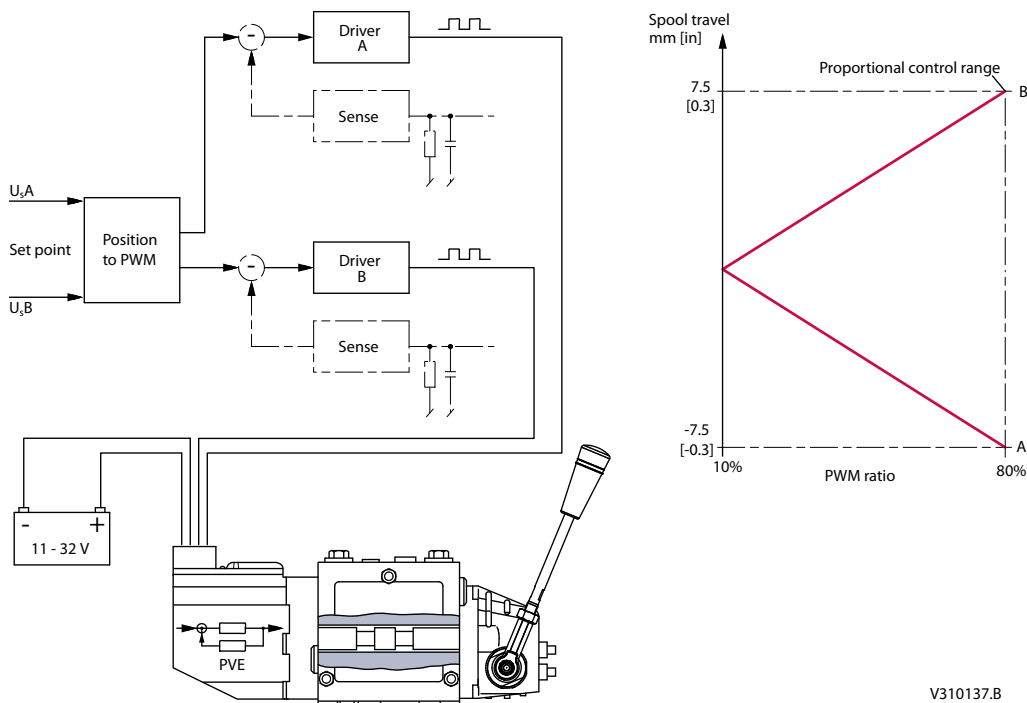

V310137.B

**Warning**

It is important that the power supply ( $U_{DC}$ ) is connected before the PWM signal.

PWM signals are low power voltage signals; hence no current drivers are needed.

PWM frequency can be chosen between 100 to 1000 Hz.

Current control is not possible with PVEP. The PVEP can also be connected to a control signal like used for PVHC.

The PVEP performs a true time difference measurement on the PWM input, thus there is no filtering or conversion involved.

*PVEP signals*

Duty cycle A-signal (pin 1)	Duty cycle B-signal (pin 2)	Function	Error Pin output (pin 3)
0%	0%	Neutral	Low
10%	0%		
0%	10%		
$\geq 10\%$	$\geq 10\%$	Fault (Error)	High
$< 10\%$	10 $\rightarrow$ 80%	B-port flow	Low

**PVE control**
*PVEP signals (continued)*

Duty cycle A-signal (pin 1)	Duty cycle B-signal (pin 2)	Function	Error Pin output (pin 3)
10 → 80%	< 10%	A-port flow	Low
A > 86%	B > 86%	Fault (Error)	High

**PVEO**
**PVE ON/OFF activation**

The PVEO has two independent powered sets of solenoids. By powering a set of pins the actuator is activated. By standard mounted PVE the A set gives full flow on A port and B gives on B port. Both directions activated at same time will keep the spool in neutral.

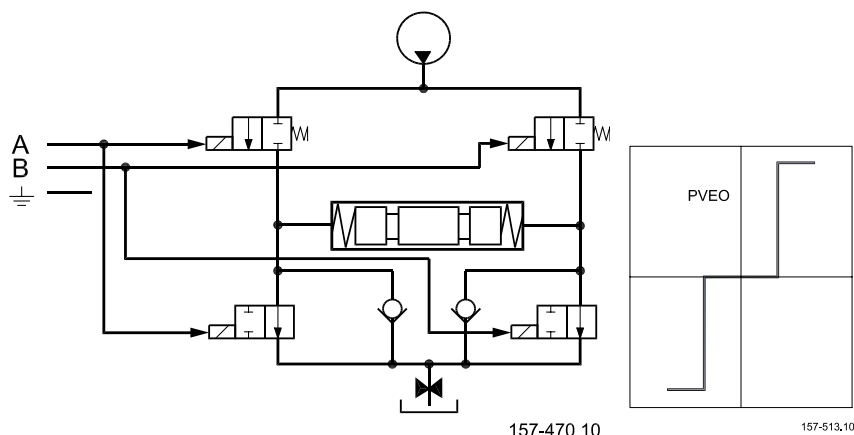
*PVEO schematic and characteristic*

**Warning**

The PVEO is designed to have  $U_{DC}=12\text{ V}$  or  $U_{DC}=24\text{ V}$ .  
The solenoids might be activated by voltage down to 6 V.

**PVE for float spool**

Danfoss has developed two PVE variants to support the float spool. The float spool is a 4/4 spool, where as the standard is a 4/3 spool giving another characteristic and maximum stroke. These variations are covered by the built-in electronics. PVE for float spools are not designed for standard 4/3 spools.

**There are two variants of float spool PVBS**

- Float A – 0.8 mm dead band, max flow at 5.5 mm. Float at A = 8 mm, from 6.2 mm partial float.  
(PVEH-F with six pin connector gives protection against entering float by using low  $U_s$ . The float signal has priority to the  $U_s$  in the PVEH-F six pin.)
- Float B – 1.5 mm dead band, max flow at 4.8 mm. Float at B = 8 mm, from 6 mm partial float.  
(PVEM-F and PVEH-F with four pin connectors give no built-in protection against entering float.)

PVE control

Variants of the float spool PVBS

Float	PVE	PVBS	Progressive control	Float control
A	PVEH-F (6 pin)	Dead band 0.8 mm Max float at 5.5 mm	$U_S$ : 25% -> 75% $U_{DC}$	$U_{DC}$ to float pin Has priority
B	PVEH-F (4 pin)	Dead band 1.5 mm Max float at 4.8 mm	$U_S$ : 35% -> 65% $U_{DC}$	$U_S = 75% U_{DC}$

PVE characteristic – Float A

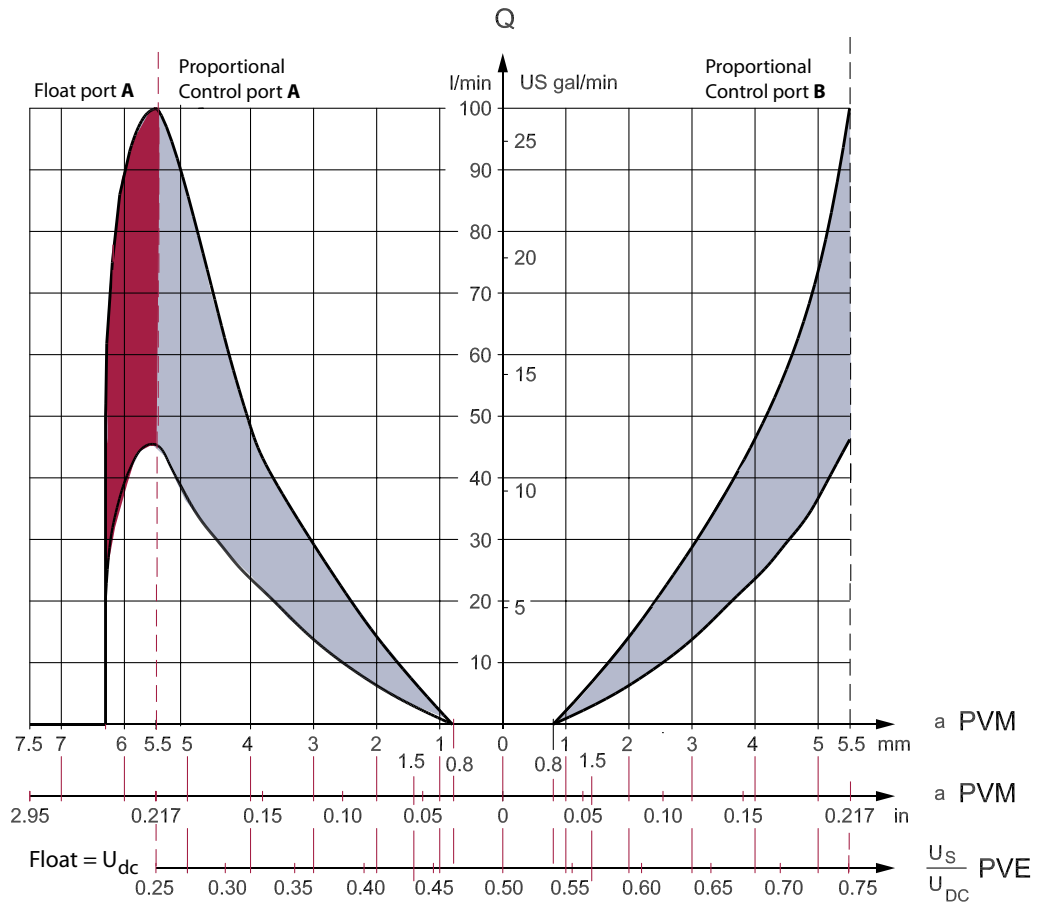

PVBS maximum float is 5.5 mm [0.22 in].

PVE has six pins.

Float when special pin powered at  $U_{DC}$ .

PVE control

PVE characteristic – Float B

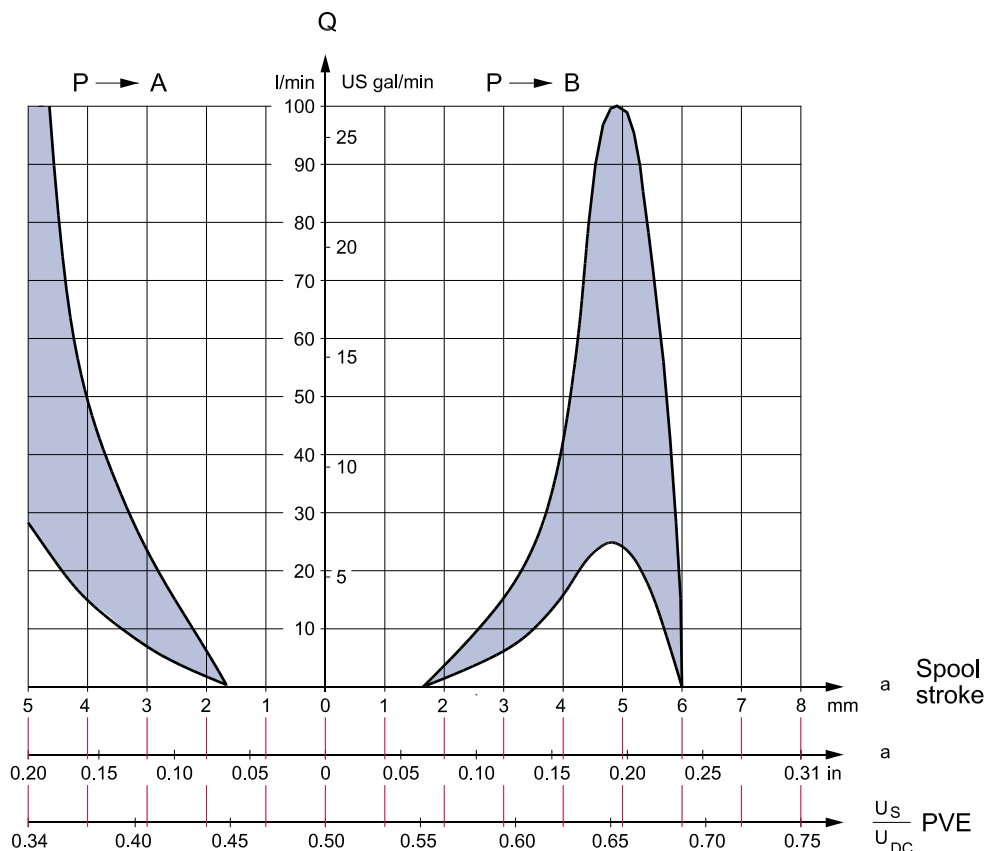

157-507.11

PVBS maximum float is 4.8 mm [0.19 in].

PVE has four pins.

Float at  $U_s / U_{DC} = 0.75$

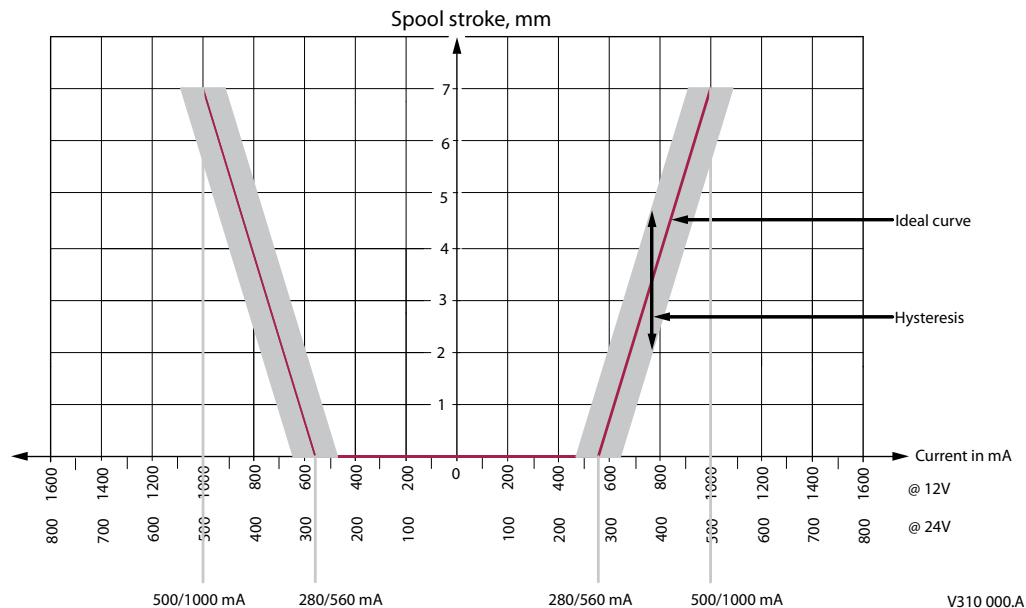
**PVE control**
**PVHC control**
*PVHC characteristic*

PVHC current response and hysteresis @ 25 bar Pp, 21 ctS, 25 °C. The PVHC control is done by dual Pulse Width Modulated (PVM) high current supply 100-400 Hz PWM control signals.

The PVHC does not have fault monitoring and internal closed loop control of the spool.

The PVHC has high hysteresis. The hysteresis is affected by viscosity, friction, flow forces, dither frequency and modulation frequency.

The spool position will shift when conditions are changed e.g. temperature change.

For PVG controlled by PVHC hysteresis is influenced by lever (PVM).

**PVE hysteresis**

The controllability of the PVE depends on the solenoid valve bridge and the electronic capacity of the module. Hysteresis is a measurement on spool position precision and repeatability. Hysteresis is not a description of position maintaining.

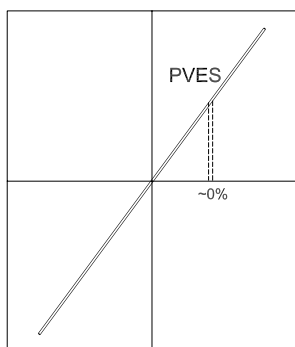
**PVE control**
**PVES Series 4**
*PVES voltage, position diagram*

157-775.10

The PVES has an ASIC closed loop circuit and the NC-S solenoids.

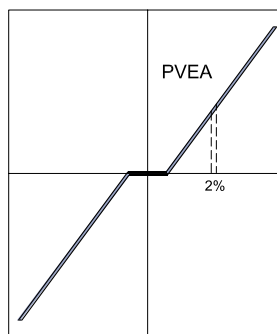
**PVEA Series 4**
*PVEA voltage, position diagram*

157-510.10

The PVEA has an ASIC closed loop circuit, standard NC solenoids and orifice instead of NO solenoids.

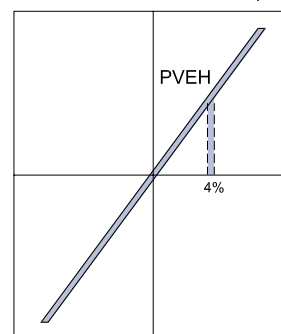
**PVEH Series 4**
*PVEH voltage, position diagram*

157-511.10

The PVEH has an ASIC closed loop circuit and the standard NC solenoids.

**Caution**

PVEA is not for use on PVG 100.

*PVE hysteresis overview*

PVE	S	A	H	M
Maximum	2 %	6 %	6 %	35 %
Typical	<1/2 %	2 %	4 %	25 %

- PVEP has the PVES characteristic.
- PVEU is available with both standard PVEH and super fine PVES characteristic.
- PVHC has hysteresis like PVEM at fixed temperature and viscosity. (For PVHC temperature and viscosity shifts control signal effect.)

**Example of PVE use**

Signal leads must not act as supply leads at the same time unless the distance between the actuator module PVE and terminal board is less than 3 m [3.3 yards] and the lead cross-section is min. 0.75 mm<sup>2</sup> [AWG 18].

**PVE control**

25 pin SUB-D connector with M3 screws (MIL-DTL-24308)

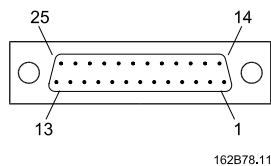
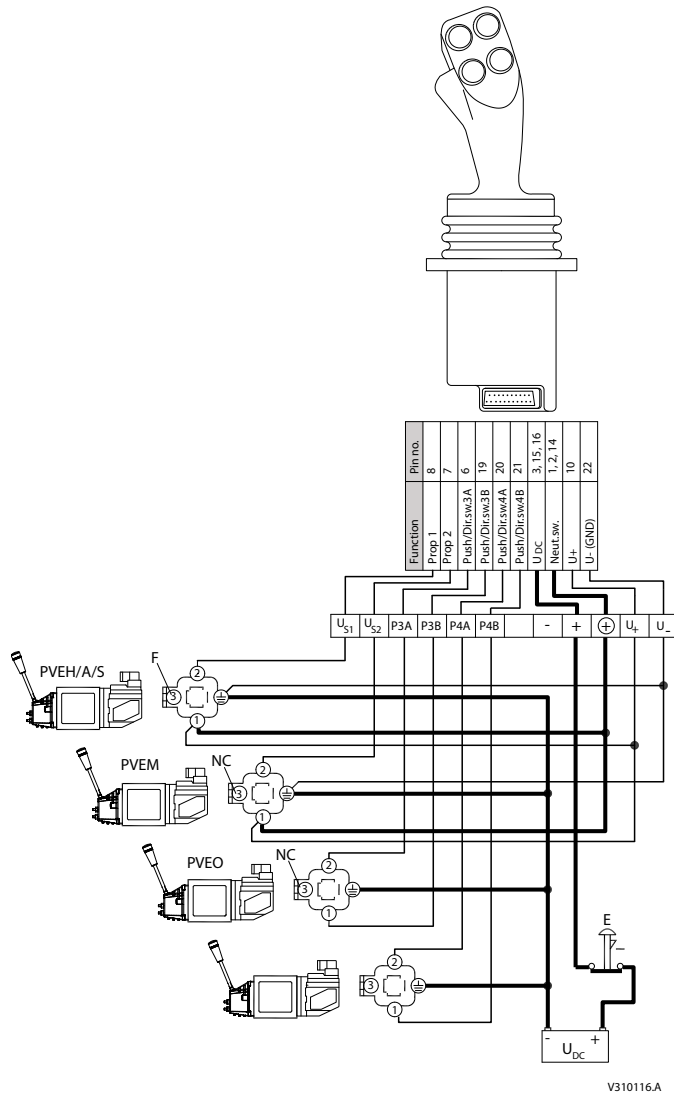

- E** – Emergency stop
- F** – Signal output, fault monitoring
- NC** – Not connected



**Technical Data**
**PVE operating parameters**
**Declaration of conformity**

The PVEA/H/P/S/U have CE marking according to the EU directive EMC Directive 2004/108/EC. The declarations are available at Danfoss.

The PVEO/M and PVHC are not subject to this directive.

**⚠ Warning**

The PVE is designed for use with pilot oil supply. Use without oil supply can harm the system. The PVE is designed for use with pilot pressure range 10 to 15 bar [145 to 220 psi]. Intermittent pressure peaks up to 50 bar [725 psi] can be accepted. Intermittent is no longer than 5 seconds and not more than once per minute.

The technical data are from typical test results. For the hydraulic system mineral based hydraulic oil with a viscosity of 21 mm<sup>2</sup>/s [102 SUS] and a temperature of 50 °C [122 °F] was used.

*Oil consumption*

Function		Supply voltage	PVEA	PVEH/ M/ O/ U–PVHC prop. high	PVEP /S / U prop. super
Pilot oil flow for PVE	neutral*	OFF	0 l/min [0 US gal/min]	0 l/min [0 US gal/min]	0.3 l/min [0.106 US gal/min]
	locked*	ON	0.4 l/min [0.106 US gal/min]	0.1 l/min [0.026 US gal/min]	0.1 l/min [0.026 US gal/min]
	continuous actuations*		1.0 l/min [0.264 US gal/min]	0.7 l/min [0.185 US gal/min]	0.8 l/min [0.211 US gal/min]

\* 12 bar [174 psi] and 21 mm<sup>2</sup>/s [102 SUS]

*Oil viscosity*

Oil viscosity	range	12 → 75 mm <sup>2</sup> /s [65 ÷ 347 SUS]
	min.	4 mm <sup>2</sup> /s [39 SUS]
	max.	460 mm <sup>2</sup> /s [2128 SUS]

*Oil temperature*

Oil temperature	range	30 → 60°C [86 ÷ 140°F]
	min.	-30°C [-22°F]
	max.	90°C [194 °F]

*Pilot pressure*

Pilot pressure		PVE (relative to T pressure)	PVHC (over tank)**
	nom.	13.5 bar [196 psi]	25 bar [363 psi]
	min.	10.0 bar [145 psi]	21 bar [305 psi]
	max.	15.0 bar [220 psi]	25 bar [363 psi]

\* Designed to be used with hydraulic activated spools

*Operating temperature*

	Minimum	Maximum
Ambient	-30°C [-22°F]	60°C [140°F]

**Technical Data**
*Operating temperature (continued)*

	Minimum	Maximum
<b>Stock</b>	-40°C [-40°F]	90°C [194°F]
<b>Recommended long time storage in packaging</b>	10°C [50°F]	30°C [86°F]

*Filtering in the hydraulic system*

<b>Required operating cleanliness level</b>	18/16/13 (ISO 4406, 1999 version)
---	-----------------------------------

For further information see Danfoss documentation *Hydraulic Fluids and Lubricants - Technical Information - 520L0463*.

*Enclosure and connector versions*

Version of connector	Hirschmann connector	AMP JPT connector	Deutsch® connector
<b>Grade of enclosure**</b>	IP 65	IP 66	IP 67

\* According to the international standard IEC 529 NB: In particularly exposed applications, protection in the form of screening is recommended.

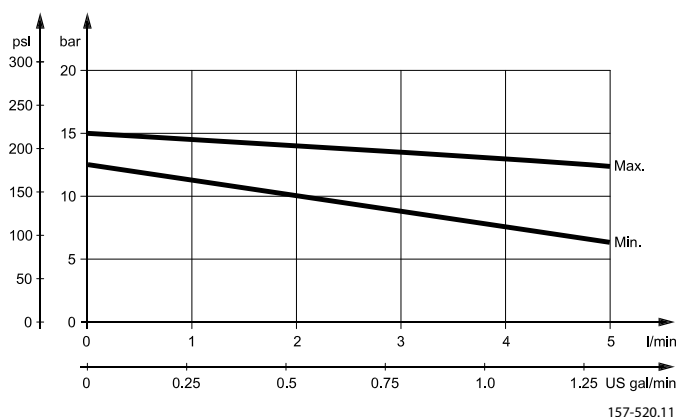
*PVP modules, Pilot pressure curves*

**PVHC control specification**
*PVHC control specification*

Supply voltage $U_{DC}$	12 V <sub>DC</sub>	24 V <sub>DC</sub>
Controller output current	0 – 1500 mA	0 – 750 mA
Pilot pressure	20 – 25 bar [290-363 psi]	
Resistance	4.75 Ω ± 5%	20.8 Ω ± 5%
Response time	150 – 200 ms	
PWM frequency	100 → 400 Hz	

*PVHC reaction time*

From neutral position to max. spool travel at power on	max.	0.235s
	rated	0.180s
	min.	0.120s

**Technical Data**
*PVHC reaction time (continued)*

From max. spool travel to neutral position at power off	max.	0.175s
	rated	0.090s
	min.	0.065s

**PVEO and PVEM control specification**
*PVEO and PVEM control specification*

Supply voltage $U_{DC}$	rated	12 V <sub>DC</sub>	24 V <sub>DC</sub>
	range	11 → 15 V	22 → 30 V
	max. ripple	5%	
Current consumption	typical	740 mA	365 mA
	minimum	550 mA	290 mA
	maximum	820 mA	420 mA
Current via DI	maximum	100 mA	

*PVEO and PVEM reaction time*

Reaction time in seconds		PVEO	PVEO-R	PVEM
From neutral position to max. spool travel at power on	max.	0.235s	0.410s	0.700s
	rated	0.180s	0.350s	0.450s
	min.	0.120s	0.250s	0.230s
From max. spool travel to neutral position at power off	max.	0.175s	0.330s	0.175s
	rated	0.090s	0.270s	0.090s
	min.	0.065s	0.250s	0.065s
From neutral position to max. spool travel by constant power	max.	–		0.550s
	min.	–		0.210s
From max. spool travel to neutral position by constant power	max.	–		0.150s
	min.	–		0.040s

**PVEA, PVEH, PVES and PVEU control specification**
*PVEA, PVEH, PVES and PVEU control specification*

Supply voltage $U_{DC}$	rated	11 → 32 V
	max. ripple	5 %
Current consumption at rated voltage	0.57 (33) A @ 12 V 0.3 (17) A @ 24 V	
Signal voltage	neutral	0.5 x $U_{DC}$ (PVEU 5V)
	A-port ↔ B-port	0.25 → 75 • $U_{DC}$
Signal current at rated voltage	0.25 → 70 mA	
Input impedance in relation to 0.5 • $U_{DC}$	12 k $\Omega$	
Power consumption	7 (3.5) W	
Error pin max current	100 mA	

**Technical Data**
*PVEA, PVEH, PVES and PVEU reaction time in sec. (minus PVG 120)*

Supply voltage	Function		PVEA Prop. fine	PVEH, PVEP, PVES, PVEU
Disconnected by means of neutral switch	Reaction time from neutral position to max. spool travel	max.	0.500	0.230
		rated	0.320	0.150
		min.	0.250	0.120
	Reaction time from max. spool travel to neutral position	max.	0.550	0.175
		rated	0.400	0.090
		min.	0.300	0.065
Constant voltage	Reaction time from neutral position to max. spool travel	max.	0.500	0.200
		rated	0.320	0.120
		min.	0.250	0.050
	Reaction time from max. spool travel to neutral position	max.	0.250	0.100
		rated	0.200	0.090
		min.	0.150	0.065

**PVEP control specification**
*PVEP control specification*

Supply voltage $U_{DC}$	range	11 → 32 V
	max. ripple	5%
	over voltage (max. 5 min)	36 V
PWM control range (duty cycle)		10 → 80%
PWM frequency		100 → 1000 Hz
PWM input voltage swing		0 → $U_{DC}$
PWM Trigger point		70% of $U_{DC}$
Input impedance (standard pull down)		5 k $\Omega$
Input capacitor		---
Power consumption		7 W
Error voltage:	Fault	$U_{DC}$
	No Fault	< 2 V

All connector terminals are short-circuit protected, protected against reverse connection and their combinations. Connecting error pins from two or more PVE's will cause the surveillance system to malfunction.

**Technical Data**

**PVE dimensions for PVG 32 and PVG 100**

*PVE with Hirschmann connector*

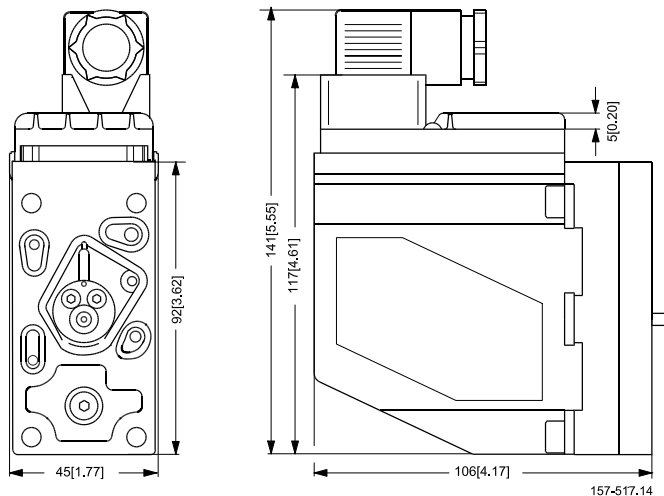

*PVE with AMP connector*

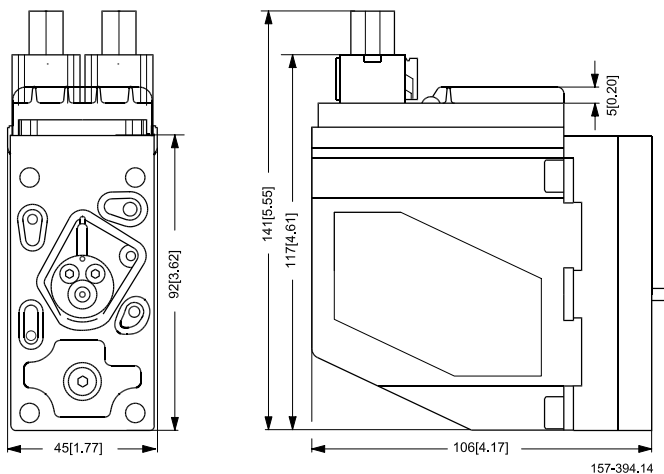

**Technical Data**

*PVE with Deutsch® connector*

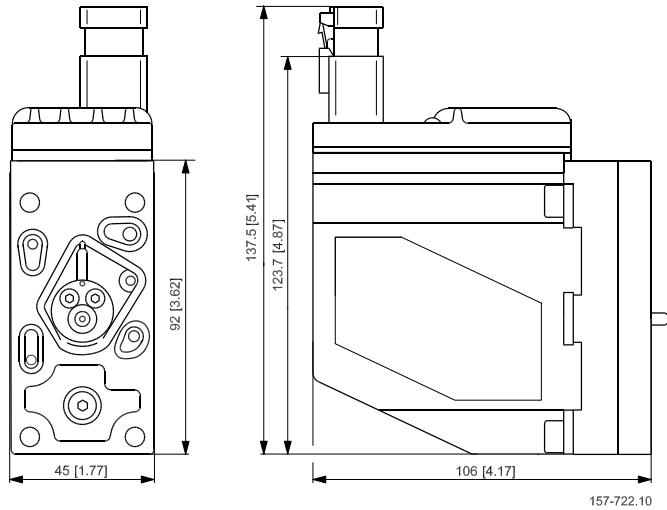

**PVHC with Deutsch® connector**

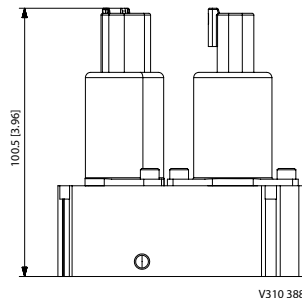
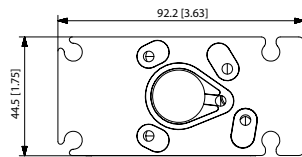

**PVHC with AMP connector**

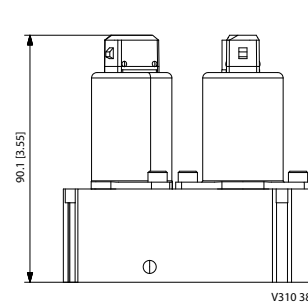
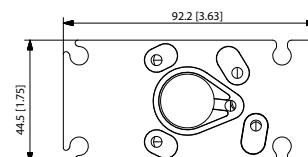

**PVE dimensions for PVG 120**

*PVE with AMP connector for PVG 120*

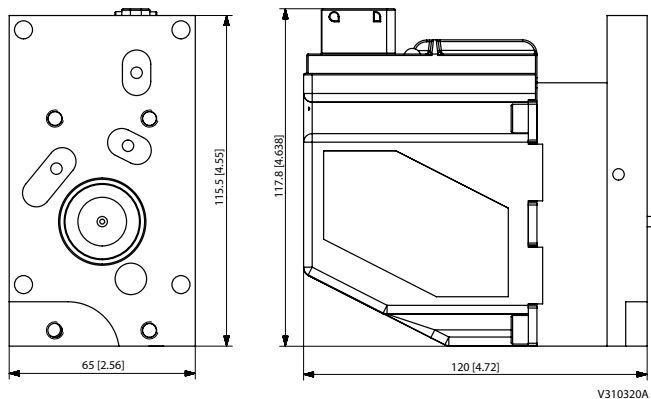

**Technical Data**

*PVE with Deutsch® connector for PVG 120*

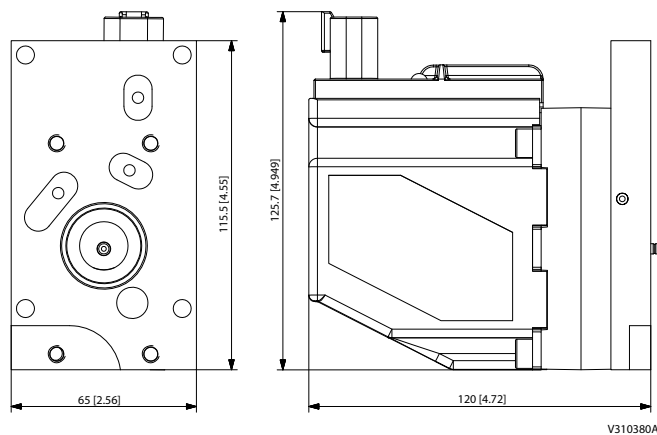

Please notice that connector needs extra space for mounting.

*PVHC with Deutsch® connector for PVG 120*

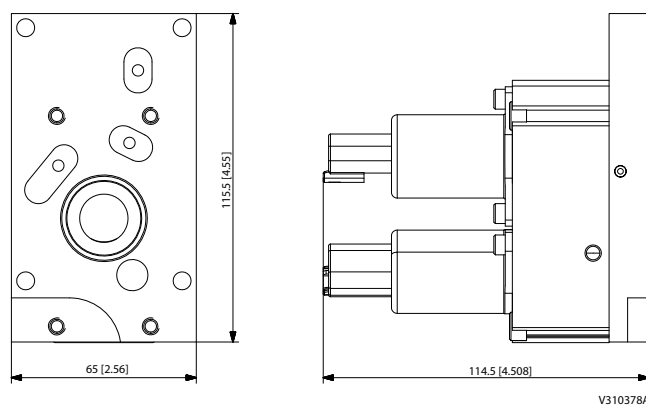

*PVG 120 and PVG 32 combo with Deutsch® connector*

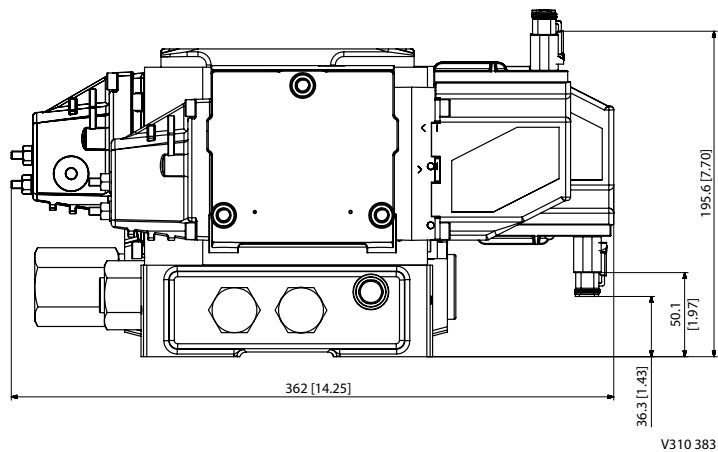

**Technical Data**
**PVEO pinout**
*PVEO with direction indication (DI) connection*

Connector 1	A $U_{DC}$	B $U_{DC}$	Gnd	Gnd
AMP (gray)	p 1	p 2	p 3	p 4

Connector 2	DI-B	DI-A	Gnd	$U_{DC2}$
AMP (black)	p 1	p 2	p 3	p 4

*PVEO standard connection*

Connector	A	B
AMP/Hirschmann/DIN	pin 1	pin 2
Deutsch*	pin 1	pin 4

Function	A (pin 1)	B (pin 2)
Neutral	0	0
Q: P → A	$U_{DC}$	0
Q: P → B	0	$U_{DC}$

*All PVEO Connections*

Connector	A	B
AMP/Hirschmann/DIN	pin 1	pin 2
Deutsch*	pin 1	pin 4

- Ground pins are internally connected.
- Pin 3 is not connected on Hirschmann/DIN version of PVEO.
- $U_{DC2}$  supplies electronics for feedback signal on PVEO-DI.

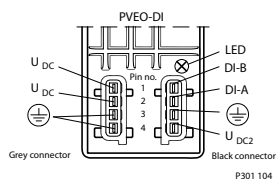
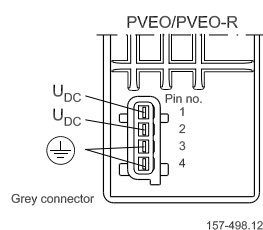
**PVEO connection**
**AMP version of PVEO-DI**

**AMP version of PVEO/PVEO-R**

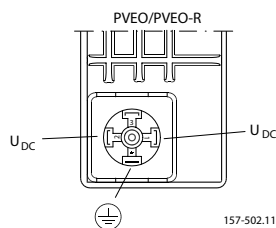
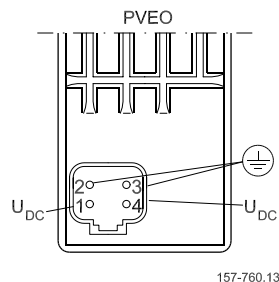

**Technical Data**
**Hirschmann/DIN version of PVEO / PVEO-R**

**Deutsch® version of PVEO**

**PVE standard connection data / pinout**

*PVEA / PVEH / PVEM / PVES / PVEU connection (also with float B, 4-pin)*

Connector	$U_S$	$U_{DC}$	Gnd	Error
AMP	pin 1	pin 2	pin 3	pin 4
Hirschmann/DIN	pin 2	pin 1	gnd	pin 3
Deutsch®	pin 1	pin 4	pin 3	pin 2

On PVEM the error pin is not used and not connected (pin 3 Hirschmann/DIN). Ground pins are internally connected.

*Control ( $U_S$ ) for standard mounted PVEA / PVEH / PVEM / PVES*

Function	Voltage relative	PWM
Neutral	$0.5 \cdot U_{DC}$	50%
Q: P → A	$0.5 \rightarrow 0.25 \cdot U_{DC}$	50% → 25%
Q: P → B	$0.5 \rightarrow 0.75 \cdot U_{DC}$	50% → 75%

*Control ( $U_S$ ) for standard mounted PVEU*

Function	PVEU
Neutral	5 V
Q: P → A	5 V → 2.5 V
Q: P → B	5 V → 7.5 V

*Control ( $U_S$ ) for standard mounted PVEH / PVEM float B, 4-pin version*

Function	Voltage relative	PWM
Neutral	$0.5 \cdot U_{DC}$	50%
Q: P → A	$0.5 \rightarrow 0.34 \cdot U_{DC}$	50% → 34%
Q: P → B	$0.5 \rightarrow 0.65 \cdot U_{DC}$	50% → 65%
Float	$0.75 \cdot U_{DC}$	75%

**PVEM is not PLUS+1® Compliant.**

Technical Data

**PVE standard connections**

**AMP version**

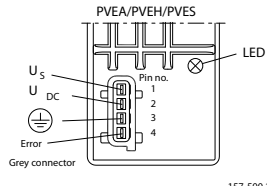

Used for PVEA/PVEH/PVES/PVEU.

**Hirschmann/DIN**

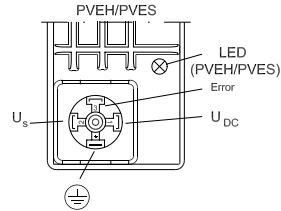

Used for PVEH/PVEM/PVES/PVEH float B/PVEM float B.

**Deutsch® version**

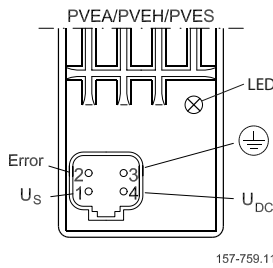

Used for PVEA/PVEH/PVES/PVEU/PVEH float B.

**Standard PVE with DI**

Connection PVE with direction indication (DI)

Connector 1	$U_s$	$U_{DC1}$	Gnd	Error
AMP (gray)	p 1	p 2	p 3	p 4
Deutsch®	p 1	p 4	p 3	p 2

Connector 2	DI-B	DI-A	Gnd	$U_{DC2}$
AMP (black)	p 1	p 2	p 3	p 4
Deutsch®	p 4	p 3	p 2	p 1 Ground pins are internally connected.

- $U_{DC2}$  only supplies electronics for feedback signal and error pin on PVEA-DI / PVEH-DI. Two separate power sources can be used.

**AMP version: PVEA-DI/PVEH-DI**

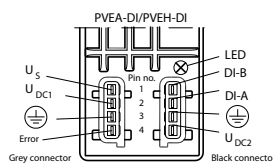

**Deutsch® version: PVEA-DI/PVEH-DI**

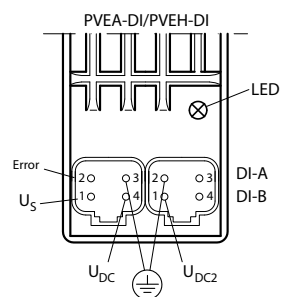

**Technical Data**
**Standard PVE with SP**

Connection PVE with Spool Position (SP)

Connector	$U_S$	Error	SP	Gnd	$U_{DC}$
Deutsch	p 1	p 2	p 4	p 5	p 6

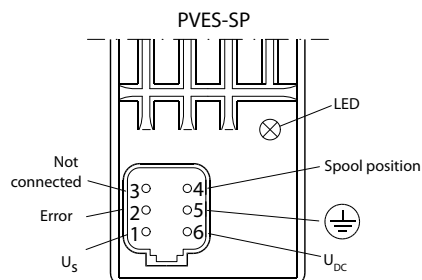
*Deutsch version: PVES-SP*

**Standard PVE with NP**

Connection PVE with Neutral Power off (NP)

Connector	$U_S$	Error	Sfb	Gnd	UDC
Deutsch*	p 1	p 2	p 4	p 5	p 6

*Control ( $U_S$ ) for standard mounted PVEA-DI/ PVEH-DI, PVES-SP, PVEA-NP, PVEH-NP*

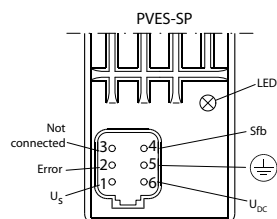
Function	$U_S$	PWM
Neutral	$0.5 \cdot U_{DC}$	50%
Q: P → A	$0.5 \rightarrow 0.25 \cdot U_{DC}$	50% → 25%
Q: P → B	$0.5 \rightarrow 0.75 \cdot U_{DC}$	50% → 75%

*Deutsch\* version: PVES-NP*

**PVHC connection**

- 100-400 Hz PWM control signals.
- Each connector controls one direction and must have  $U_{DC}$  and ground
- No constraints on pin for  $U_{DC}$  and ground.

**Technical Data**
*Input control*

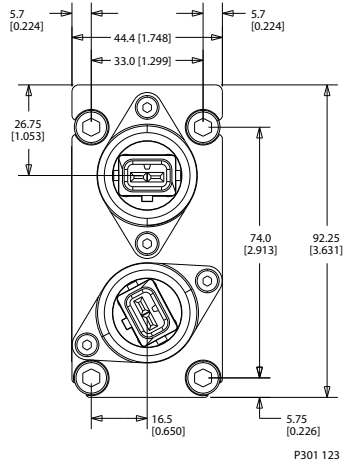
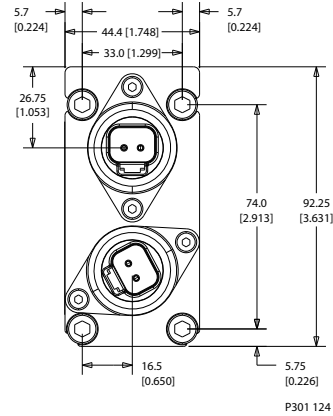
Parameter	Control range	
	12 V	24 V
Controller output current range	0 - 1500 mA	0 - 750 mA

**PVHC with AMP version**

**PVHC with Deutsch® version**

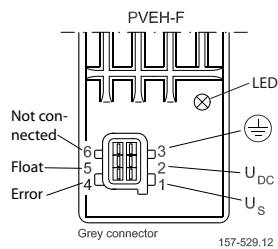
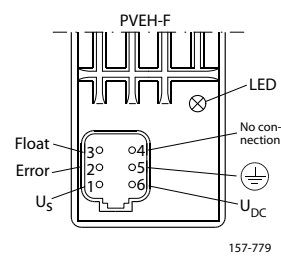
**PVE with separate float pin**
*PVEH with float A, 6-pin connection*

Connector	$U_S$	$U_{DC}$	Float	Ground	Error
AMP	pin 1	pin 2	pin 5	pin 3	pin 4
Deutsch®	pin 1	pin 6	pin 3	pin 5	pin 2

**AMP with separate float pin**

**Deutsch® version with separate float pin**

**PVEP with controlled PWM**
*PVEP connection*

Connector	PWM A	Error	PWM B	Gnd	$U_{DC}$
Deutsch®	p 1	p 2	p 3	p 5	p 6

**Technical Data**

*Control (U<sub>c</sub>) for standard mounted PVEP*

<b>Function</b>	<b>Voltage relative</b>	<b>PWM</b>
Neutral	< 10%	< 10%
Q: P → A	10% → 80%	< 10%
Q: P → B	< 10%	10% → 80%

**PVE warnings****PVE warnings**** Warning**

---

Not applying to the Operational Conditions can compromise safety.

All brands and all types of directional control valves – including proportional valves – can fail and cause serious damage. It is therefore important to analyze all aspects of the application. Because the proportional valves are used in many different operation conditions and applications, the machine builder/ system integrator alone is responsible for making the final selection of the products – and assuring that all performance, safety and Warning requirements of the application are met.

A PVG with PVE can only perform according to description if conditions in this Technical Information are met.

In particularly exposed applications, protection in the form of a shield is recommended.

When the PVE is in fault mode the quality of performance and validity of feedback is limited depending on the fault type.

Error pins from more PVEs may not be connected. Inactive error pins are connected to ground and will disable any active signal. Error pins are signal pins and can only supply very limited power consumption. Deviation from recommended torque when mounting parts can harm performance and module.

Adjustment of the position transducer (LVDT) will influence calibration, and thereby also safety and performance.

When replacing the PVE, the electrical and the hydraulic systems must be turned off and the oil pressure released.

PVEA is not for use on PVG 100.

Hydraulic oil can cause both environmental damage and personal injury.

Module replacement can introduce contamination and errors to the system. It is important to keep the work area clean and components should be handled with care.

After replacement of modules or cables wiring quality must be verified by a performance test.

By actuation at voltage below nominal PVG will have reduced performance.

The PVE is not designed for use with voltage outside nominal.

Obstacles for the Pilot oil can have direct influence on spool control.

Reduced pilot oil pressure will limit spool control.

Too high pilot oil pressure can harm the PVE.

---

**PVE code numbers**
**PVE code numbers for PVG 32 and PVG 100 use**
*Deutsch® connector code numbers*

Feature		S	std.	float A	float B	DI	NP	SP	Fast-no memory	ramp
Connector			1x4	1x6	1x4	2x4	1x6	1x6	1x4	
PVEA*	active	-	157B4792			157B4796	11105542			
	passive		11107365							
PVEH	active		157B4092	157B4398		157B4096	11105543			
	passive		157B4093		157B4392					
PVES	active	S	157B4892						157B4894	
	passive	S	11089276					11108994		
PVEP	active	S	11034832*							
PVEU	passive	S	11089090							
PVEO	12V	-	157B4291							11109080
	24V		157B4292							11109092

\* 1x6 = one plug six pins

S = super fine hysteresis, 1x4 = one plug four pins

*AMP connector code numbers*

Feature		S	std.	float A	DI	anodized	ramp-ano	ramp
Connector			1x4	1x6	2x4	1x4	1x4	1x4
PVEA*	active	-	157B4734		157B4736			
	passive		157B4735		157B4737	157B4775		
PVEH	active		157B4034	157B4338	157B4036	157B4074		
	passive		157B4035		157B4037	157B4075		
PVES	active	S	157B4834					
	passive	S	157B4835			157B4865		
PVEU	active	S	11089091					
	active	-	157B4044					
	passive		157B4045					
PVEO	12V		157B4901		11157283			157B4903
	24V		157B4902		11157282	157B4272	157B4274	157B4904

\* 1x6 = one plug six pins

S = super fine hysteresis, 1x4 = one plug four pins

**Warning**

PVEA is not for use on PVG 100.

*Hirschmann/DIN connector code numbers*

Feature		S	std.	float B	anodized	ramp
Connector			1x4	1x4	1x4	1x4
PVEH	active		157B4032	157B4332		
	passive		157B4033		157B4073	

**PVE code numbers**
*Hirschmann/DIN connector code numbers (continued)*

Feature		S	std.	float B	anodized	ramp
Connector			1x4	1x4	1x4	1x4
PVES	active	S	157B4832			
	passive	S	157B4833			
PVEM	12 V		157B4116	157B4416		157B4516
	24 V		157B4128	157B4428		157B4528
PVEO	12 V		157B4216		157B4266	157B4217
	24 V		157B4228		157B4268	157B4229

S = super fine hysteresis, 1x4 = one plug four pins

*ATEX (24 V) connector code numbers*

Cable type		S	PFOP	PFOP	PFOP, cable dir PVB	BFOU
Flying wire			5 m	10 m	5 m	5 m
PVEH	passive		11084101	11084109	11084092	11084098
PVES		S	11084102	11084110	11084093	11084099
PVEO			11084100	11084108	11084051	11084097

S = super fine hysteresis

*AMP/Deutsch® code numbers for PVHC*

Connector		Code Number
PVHC AMP	12 V	11112037
	24 V	11112036
PVHC Deutsch®	12 V	11112038
	24 V	11112039

**PVE code numbers for use on PVG 120**
*AMP code numbers*

Feature		anodized
Connector		1x4 = one plug x four pins
PVEH	active	155G4094
	passive	155G4095
PVEO	12 V	155G4282
	24 V	155G4284

*Hirschmann/DIN code numbers*

Feature		anodized
Connector		1x4 = one plug x four pins
PVEH	active	155G4092
	passive	155G4093
PVES	passive	11111210



**PVE code numbers**
*Hirschmann/DIN code numbers (continued)*

Feature		anodized
Connector		1x4 = one plug x four pins
PVEO	12 V	155G4272
	24 V	155G4274

*Deutsch code numbers*

Feature		anodized
Connector		1x4 = one plug x four pins
PVEH	passive	11111206
PVES	passive	11111207
PVEO	12 V	11110601
	24 V	11110652
PVHC	12 V	11110597
	24 V	11110598

*ATEX (24 V) connector code numbers*

Cable type		PFOP	PFOP	PFOP, cable dir PVB	BFOU
Flying wire		5 m	10 m	5 m	5 m
PVEH	passive	11084104	11084112	11084096	11084107
PVEO		11084103	11084111	11084095	11084106

**PVE accessories**
*Connector code numbers*

Code number	Description	
157B4992	AMP CONNECTING KIT (GREY)	4 pin with housing, contact and wire sealing
157B4993	AMP CONNECTING KIT (BLACK)	4 pin with housing, contact and wire sealing
984L3156	EL-PLUG, ON-OFF black	Hirschmann DIN connector set*

*Set of seals code numbers*

Code number	Description	Actuator
157B4997	Set of seals	PVE for PVG 32/ PVG 100
155G8519		PVE for PVG 120 (also interface plate/PVB for PVHC)
11061235		PVHC for PVG 32/ PVG 100

**Technical Information PVE, Series 4 for PVG 32/100/120 and PVHC**
**PVE code numbers**
*Cables code numbers*

Feature		Wire colors						Length	Code number
Connector		pin 1	pin 2	pin 3	pin 4	pin 5	pin 6		
Deutsch	4 pin	white	blue	yellow	red	—	—	4 m	11007498
	4 pin	white	blue	yellow	red	—	—	4 m	11099720 *24V
	6 pin	white	blue	yellow	red	black	green	4 m	11007513
AMP	4 pin	white	blue	yellow	red	—	—	4 m	157B4994
	4 pin	white	blue	yellow	red	—	—	4 m	11099719 *24V
	6 pin	white	red	black	yellow	green	blue	5 m	157B4974
AMP/black coding	4 pin	white	blue	yellow	red	—	—	4 m	157B4995 **-DI

Cables are with oil resistant coating.

\* 24 V Special cable for use with PLUS+1<sup>®</sup> micro-controller in 24 V systems.

\*\* -DI additional cable for PVE with direction indication.

**Connector code numbers at other suppliers**
*Connector part numbers for purchase at other suppliers*

Connector		House	wire sealing (blue)	JPT contact (loose piece)	sealing mat between male-female part
Deutsch <sup>®</sup> female	4 pin	DT06-4S	—	—	—
	6 pin	DT06-6S			
AMP female/gray	4 pin	2-967059-1	828904-1	929930-1	963208-1
	6 pin	2-963212-1			963205-1
AMP female/black	4 pin	1-967059-1	—	—	—
AMP crimp tool		169400-1			
AMP die set for crimp tool		734253-0			

[These connector code numbers are not Danfoss numbers.](#)

**PVED-CC code numbers for use on PVG 32 and PVG 100**
*Cables code numbers for PVED-CC*

Feature		Wire colors				Description	Code number
Connector		pin 1	pin 2	pin 3	pin 4		
Deutsch <sup>®</sup>	4 pin	white	blue	yellow	red	4 m cable	11007498
AMP	4 pin	white	blue	yellow	red	4 m cable	157B4994
AMP/black	4 pin	white	blue	yellow	red	4 m cable	157B4995

*Cables code numbers for PVED-CC (continued)*

Feature		Description	Code number
Connector			
Service tool interface cable/ AMP		4 m cable	157B4977
AMP		0.1m loop cable	157B4987
AMP/black		Terminator	157B4988

---

**Technical Information PVE, Series 4 for PVG 32/100/120 and PVHC**

---

**PVE code numbers**

*Cables code numbers for PVED-CC (continued) (continued)*

<b>Feature</b>	<b>Description</b>	<b>Code number</b>
<b>Connector</b>		
Deutsch*	0.1m loop cable	11007531
Deutsch*	Terminator	11007561
Deutsch*	Terminator dummy	11007563

*CAN Interface*

10104136	CG 150 CAN USB interface
----------	--------------------------

<b>Connector</b>		<b>2x4 = two plugs x four pins</b>
Deutsch*	SW 2.68	11079033
AMP	SW 2.68	11079034



**Products we offer:**

- Bent Axis Motors
- Closed Circuit Axial Piston Pumps and Motors
- Displays
- Electrohydraulic Power Steering
- Electrohydraulics
- Hydraulic Power Steering
- Integrated Systems
- Joysticks and Control Handles
- Microcontrollers and Software
- Open Circuit Axial Piston Pumps
- Orbital Motors
- PLUS+1® GUIDE
- Proportional Valves
- Sensors
- Steering
- Transit Mixer Drives

**Danfoss Power Solutions** is a global manufacturer and supplier of high-quality hydraulic and electronic components. We specialize in providing state-of-the-art technology and solutions that excel in the harsh operating conditions of the mobile off-highway market. Building on our extensive applications expertise, we work closely with our customers to ensure exceptional performance for a broad range of off-highway vehicles.

We help OEMs around the world speed up system development, reduce costs and bring vehicles to market faster.

Danfoss – Your Strongest Partner in Mobile Hydraulics.

**Go to [www.powersolutions.danfoss.com](http://www.powersolutions.danfoss.com) for further product information.**

Wherever off-highway vehicles are at work, so is Danfoss. We offer expert worldwide support for our customers, ensuring the best possible solutions for outstanding performance. And with an extensive network of Global Service Partners, we also provide comprehensive global service for all of our components.

Please contact the Danfoss Power Solution representative nearest you.

**Comatrol**

[www.comatrol.com](http://www.comatrol.com)

**Schwarzmueller-Inverter**

[www.schwarzmueller-inverter.com](http://www.schwarzmueller-inverter.com)

**Turolla**

[www.turollaocg.com](http://www.turollaocg.com)

**Valmova**

[www.valmova.com](http://www.valmova.com)

**Hydro-Gear**

[www.hydro-gear.com](http://www.hydro-gear.com)

**Daikin-Sauer-Danfoss**

[www.daikin-sauer-danfoss.com](http://www.daikin-sauer-danfoss.com)

Local address:

**Danfoss Power Solutions (US) Company**  
2800 East 13th Street  
Ames, IA 50010, USA  
Phone: +1 515 239 6000

**Danfoss Power Solutions GmbH & Co. OHG**  
Krokamp 35  
D-24539 Neumünster, Germany  
Phone: +49 4321 871 0

**Danfoss Power Solutions ApS**  
Nordborgvej 81  
DK-6430 Nordborg, Denmark  
Phone: +45 7488 2222

**Danfoss Power Solutions (Shanghai) Co., Ltd.**  
Building #22, No. 1000 Jin Hai Rd  
Jin Qiao, Pudong New District  
Shanghai, China 201206  
Phone: +86 21 3418 5200

Danfoss can accept no responsibility for possible errors in catalogues, brochures and other printed material. Danfoss reserves the right to alter its products without notice. This also applies to products already on order provided that such alterations can be made without changes being necessary in specifications already agreed. All trademarks in this material are property of the respective companies. Danfoss and the Danfoss logotype are trademarks of Danfoss A/S. All rights reserved.