

Technical Information

# PVE Series 7

## Electro-hydraulic Actuators



**Revision history**

*Table of revisions*

<b>Date</b>	<b>Changed</b>	<b>Rev</b>
March 2020	Various updates to data.	0307
April 2019	All reaction times tables, notes changes.	0204
December 2018	New image on page 5-6.	0203
July 2018	Minor update.	0202
June 2018	PVE actuation, connector image changes.	0201
May 2018	Restored missing information.	0105
April 2018	Minor updates.	0104
February 2017	Added detailed Fault Monitoring description	0103
January 2017	Minor updates	0102
November 2016	First edition	0101

## Contents

### PVE Electrical Actuator

PVE Series 7 Electrical Actuator.....	5
PVE Series 7 variants overview.....	6
Safety in Systems.....	8

### PVEO

PVEO Schematics and Dimensions.....	11
PVEO Technical Data.....	11
PVEO Reaction Times.....	12
PVEO Variants for PVG.....	13

### PVEO-HP

PVEO-HP Schematics and Dimensions.....	16
PVEO-HP Technical Data.....	16
PVEO-HP Reaction Times.....	17
PVEO-HP Variants for PVG.....	18

### PVEM

PVEM Schematics and Dimensions.....	20
PVEM Technical Data.....	20
PVEM Reaction Times.....	22
PVEM Hysteresis and Ripple.....	22
PVEM Variants for PVG.....	23

### PVEA

PVEA Schematics and Dimensions.....	25
PVEA Technical Data.....	25
PVEA Reaction Times.....	27
PVEA Hysteresis and Ripple.....	27
PVEA Variants for PVG.....	28

### PVEH

PVEH Schematics and Dimensions.....	30
PVEH Technical Data.....	30
PVEH Reaction Times.....	32
PVEH Hysteresis and Ripple.....	32
PVEH Variants for PVG.....	33

### PVES

PVES Schematics and Dimensions.....	36
PVES Technical Data.....	36
PVES Reaction Times.....	38
PVES Hysteresis and Ripple.....	38
PVES Variants for PVG.....	39

### Connector Overview

Connector Overview.....	40
-------------------------	----

### Fault Monitoring and Reaction

Generic Fault Reaction.....	42
Fault Reaction Overview.....	43
Error Pin Specification.....	43

### Functionality Overview

Standard and Fixed US 0-10 Vdc.....	44
PWM Voltage Control.....	45
Ramp (-R).....	47
Quick Reaction (-Q).....	48
Float B-Port (-FLB).....	49
Float A-Port (-FLA).....	50
PVE Power Save.....	50

### Special Features

Direction Indication (-DI).....	51
---------------------------------	----

**Contents**

Dedicated Float Pin (UF)..... 53  
Spool Position (SP)..... 54  
Neutral Power-OFF (NP)..... 55  
Disable Mode..... 56

**Performance Overview**

PVE S7 Reaction Times..... 57  
Hysteresis and Ripple..... 57  
Current Consumption..... 58  
Oil Consumption..... 58

**Dimension Overview**

Dimension Overview for PVE Series 7..... 59

**PVE Electrical Actuator**

**PVE Series 7 Electrical Actuator**

The analog PVE Series 7 is an electro-hydraulic actuator used to control a single work section of a PVG proportional valve group. The PVE Series 7 actuator program includes variants with different performance levels and features for PVG 32/100/120/128/256.

The actuator positions the main spool in a PVG work section in order to control either the flow or the pressure of the oil distributed to/from the work function. The control signal to the actuator is an analog voltage signal, enabling the user to operate the work function remotely by means of a joystick, a controller or the similar.

The analog PVE Series 7 actuator program features five different main hydraulic principle variants (PVEO/PVEM/PVEA/PVEH/PVES). The different hydraulic principles combined with the different solenoid valve regulation principles determine whether the actuator controls the spool proportionally according to a demand signal or ON/OFF according to a voltage signal.

The electro-hydraulic solenoid valve bridge of the actuator is available in different designs utilizing different regulation principles, depending on performance variant. The actuator positions the main spool by distributing pilot oil pressure to either side of it, pressurizing one side by pilot pressure while relieving the opposite side to tank and vice versa, as illustrated below. All proportional actuators feature a closed-loop spool control and continuous fault monitoring.

*PVG 32 with PVEO/PVEM (PVEO without LVDT)*

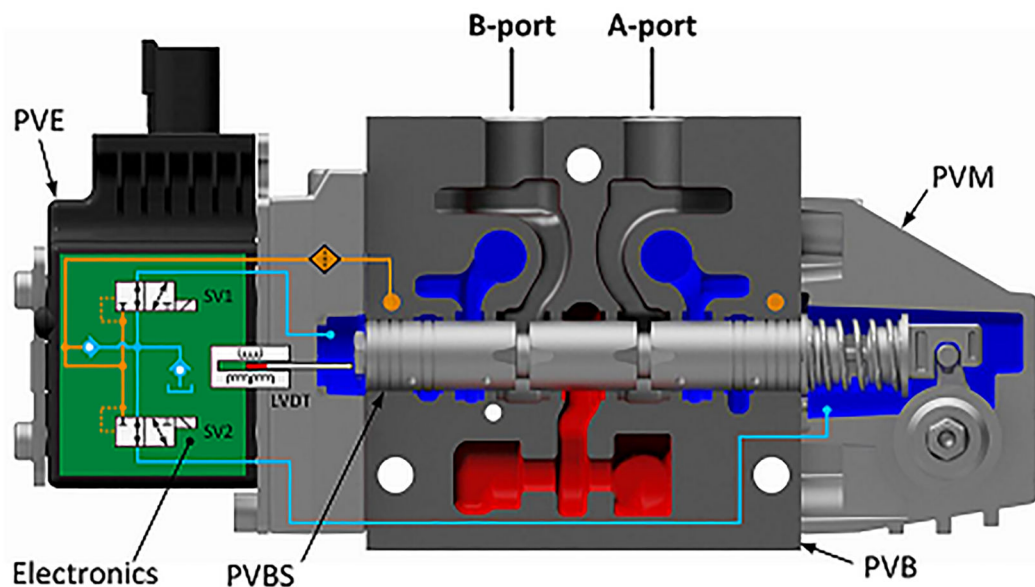

**PVE Electrical Actuator**

PVG 32 with PVEH/PVES

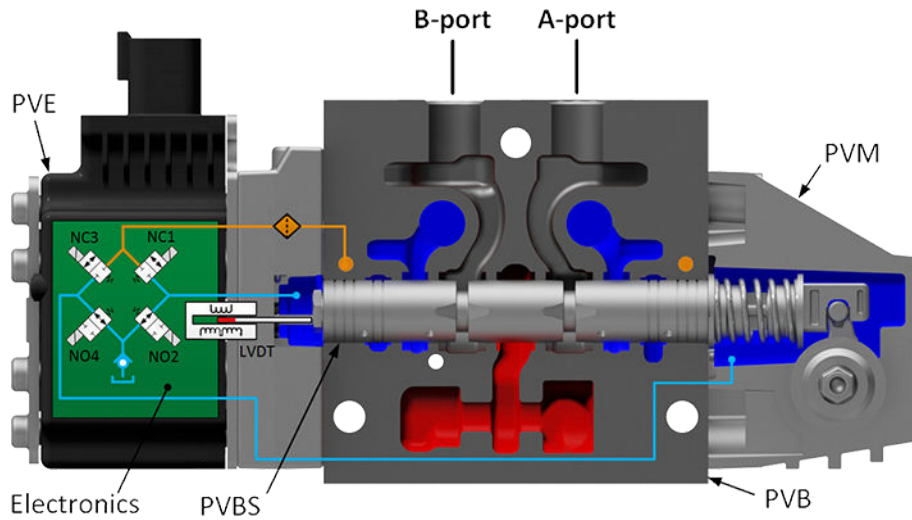

PVEA has the same housing as PVEO/PVEM and similar hydraulic principle as PVEH/PVES, but with fixed orifices instead of NO2 and NO4.

**PVE Series 7 variants overview**

Schematic	Description
<p>PVEO schematic</p>	<p><b>PVEO</b> – ON/OFF voltage control for non-proportional functions, see <a href="#">PVEO</a></p> <ul style="list-style-type: none"> <li>• Neutral position or max. spool stroke according to control signal</li> <li>• 12 V<sub>DC</sub> or 24 V<sub>DC</sub> supply voltage</li> <li>• DEUTSCH, AMP or DIN/Hirschman connectors</li> <li>• Standard PVE pilot oil pressure of 13.5 bar [196 psi]</li> <li>• LED only indicating Power ON or Power OFF</li> <li>• Ramp (-R) or Direction Indication output (-DI) functionality</li> </ul>
<p>PVEO-HP schematic</p>	<p><b>PVEO-HP</b> – ON/OFF voltage control for non-proportional functions, see <a href="#">PVEO-HP</a></p> <ul style="list-style-type: none"> <li>• Neutral position or max. spool stroke according to control signal</li> <li>• 12 V<sub>DC</sub> or 24 V<sub>DC</sub> supply voltage</li> <li>• DEUTSCH, AMP or DIN/Hirschman connectors</li> <li>• To be used with PVH/PVHC pilot oil pressure of 25 bar</li> <li>• LED only indicating Power ON or Power OFF</li> </ul>

**PVE Electrical Actuator**

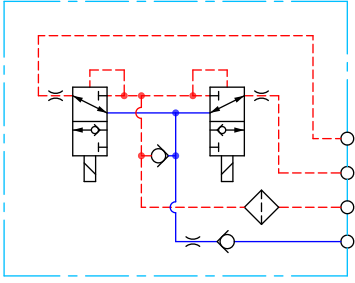
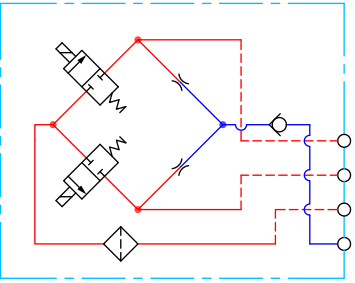
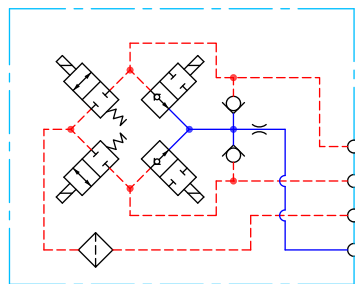
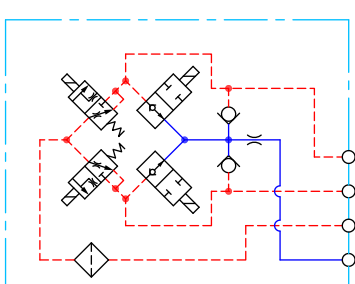
Schematic	Description
<p><i>PVEM schematic</i></p>  <p style="text-align: right;">P109196</p>	<p><b>PVEM</b> – proportional spool control for functions with medium performance demands, see <a href="#">PVEM</a></p> <ul style="list-style-type: none"> <li>• 9–32 V<sub>DC</sub> multi-voltage power supply</li> <li>• DIN or Hirschman connectors</li> <li>• Standard PVE pilot oil pressure of 13.5 bar [196 psi]</li> <li>• LED indicating error state and passive fault monitoring</li> <li>• Float (-F), quick Ramp (-R) or Quick reaction functionality (-Q)</li> </ul>
<p><i>PVEA schematic</i></p>  <p style="text-align: right;">P109197</p>	<p><b>PVEA</b> – proportional spool control for functions with high performance demands, see <a href="#">PVEA</a></p> <ul style="list-style-type: none"> <li>• 9–32 V<sub>DC</sub> multi-voltage power supply</li> <li>• Variants available with DEUTSCH or AMP connectors</li> <li>• Standard PVE pilot oil pressure of 13.5 bar [196 psi]</li> <li>• LED indicating error state and active or passive fault monitoring</li> <li>• Direction Indication output (-DI) or Neutral Power-Off (-NP) functionality</li> </ul>
<p><i>PVEH schematic</i></p>  <p style="text-align: right;">P109198</p>	<p><b>PVEH</b> – proportional spool control for functions with high performance demands, see <a href="#">PVEH</a></p> <ul style="list-style-type: none"> <li>• 9–32 V<sub>DC</sub> multi-voltage power supply</li> <li>• DEUTSCH, AMP or DIN/Hirschman connectors</li> <li>• Standard PVE pilot oil pressure of 13.5 bar [196 psi]</li> <li>• LED indicating error state and active or passive fault monitoring</li> <li>• Float (-F), Direction Indication output (-DI), Neutral Power-Off (-NP), Spool Position output (-SP) or 0-10 V<sub>DC</sub> control signal (-U) functionality</li> </ul>
<p><i>PVES Schematic</i></p>  <p style="text-align: right;">P109199</p>	<p><b>PVES</b> – proportional spool control for functions with high performance and reaction demands, see <a href="#">PVES</a></p> <ul style="list-style-type: none"> <li>• 9–32 V<sub>DC</sub> multi-voltage power supply</li> <li>• Analog voltage control signal 25-75% of supply voltage</li> <li>• DEUTSCH, AMP or DIN/Hirschman connectors</li> <li>• Standard PVE pilot oil pressure of 13.5 bar [196 psi]</li> <li>• LED indicating error state and active or passive fault monitoring</li> <li>• Variants available with Spool Position output (-SP) or 0-10 V<sub>DC</sub> control signal (-U) functionality</li> </ul>

## PVE Electrical Actuator

### Safety in Systems

All types and brands of control valves, including proportional valves, can fail. Therefore, the necessary protection against the serious consequences of a functional failure should always be built into the system.

#### General safety considerations

For each application an assessment should be made for the consequences of the system in case of pressure failure and uncontrolled or blocked movements.

#### **Warning**

---

Because the proportional valve is used in many different applications and under different operating conditions, it is the sole responsibility of the manufacturer to ensure that all performance, safety and warning requirements of the application is met in his selection of products and complies with relevant machine specific and generic standards.

---

#### Control system example

An example of a control system using an aerial lift is shown below:

*Aerial lift*

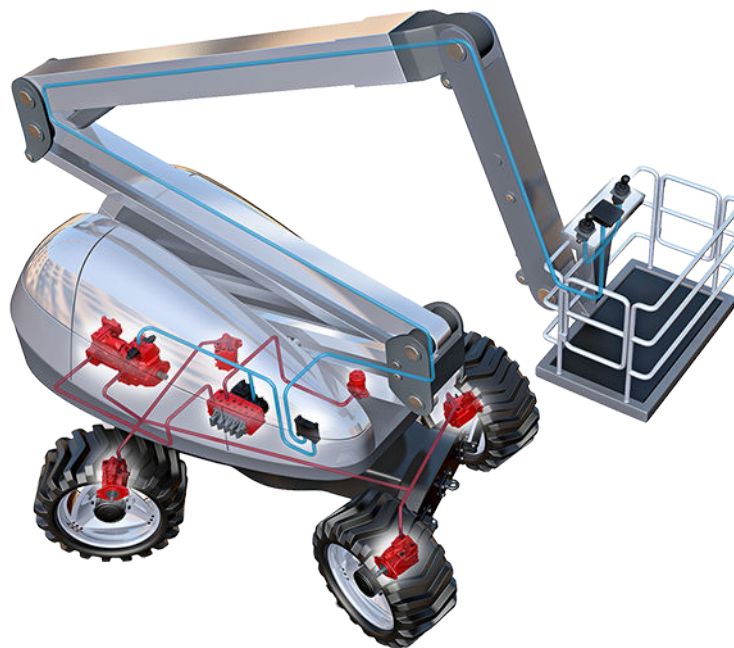

This example breaks down the control system into smaller bits explaining the architecture in depth. Even though many Danfoss components are used in the PVG control system.

The function of the control system is to use the output from the PVE together other external sensors to ensure the PLUS+1 main controllers correct function of the aerial lift.



**PVE Electrical Actuator**

*Electrical block diagram*

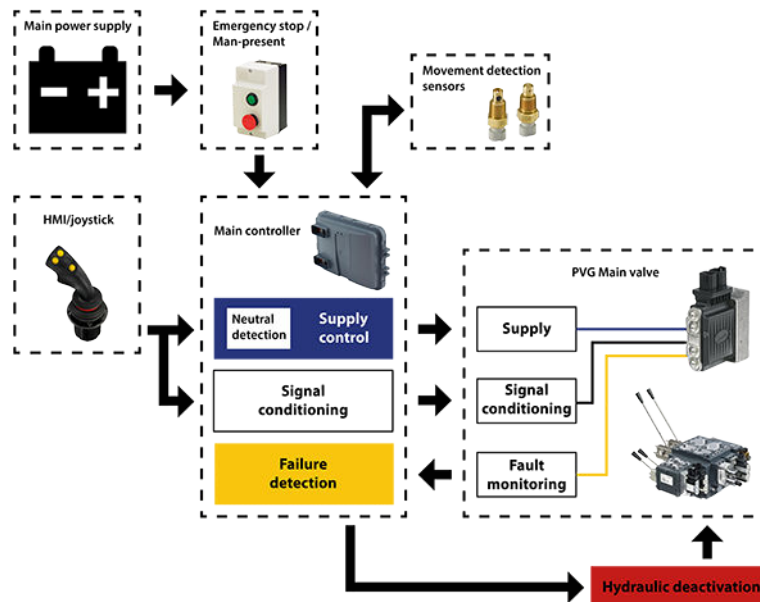

**⚠ Warning**

It is the responsibility of the equipment manufacturer that the control system incorporated in the machine is declared as being in conformity with the relevant machine directives.

**⚠ Caution**

A mix of electrical actuation and hydraulic actuation on the same valve stack is not safe. PVE and PVH are designed for different pilot pressure.

Cost-free repairs, as mentioned in Danfoss General Conditions of Sale, are carried out only at Danfoss or at service shops authorized by Danfoss.

**PVEO**

The PVEO actuator is a non-proportional ON/OFF control actuator with open-loop spool control primarily used to control simple ON/OFF work functions where a proportional control of speed or oil flow is not a requirement

The PVEO is available in two different performance variants, the standard PVEO and the PVEO-R with ramp.

*PVEO*

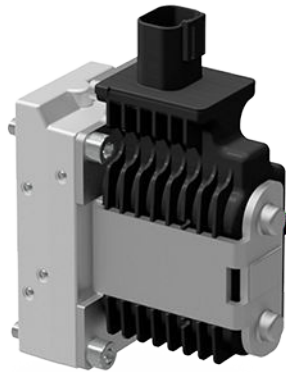

**PVEO functionality**

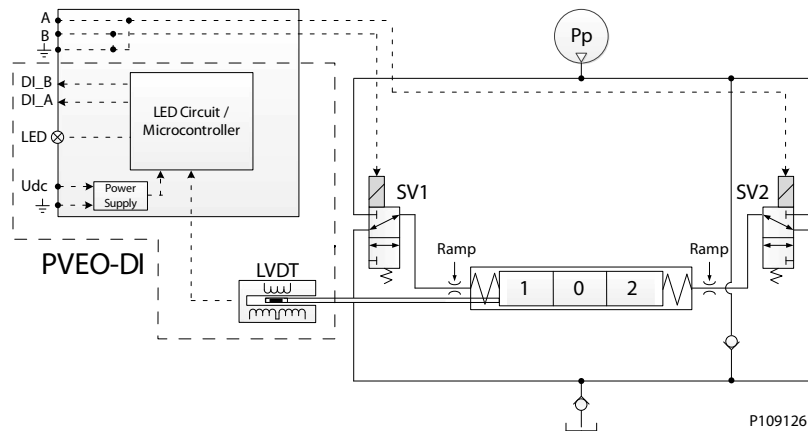

The standard PVEO functionality includes the simplest electric circuit of the PVE Series 7 actuator program, using a fixed 12 Vdc or 24 Vdc supply voltage or signal voltage and a simple LED circuit to control the LED light indicating Power ON/OFF.

The PVEO-DI variant includes an LVDT spool position monitor and a more advanced electric circuit with an embedded micro-controller and separate power supply to handle the Direction Indication functionality.

An energization of solenoid valve SV1 and a simultaneous de-energization of SV2 will cause the main spool to move to the right direction and vice versa. If both SV1 and SV2 are energized or de-energized simultaneously, the main spool stays locked in its neutral position.

**PVEO**

**PVEO Schematics and Dimensions**

*Schematics*

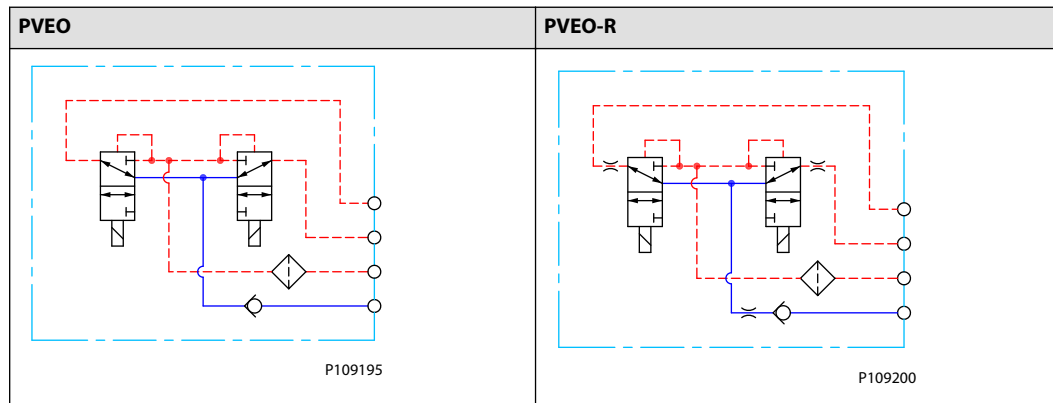

*Dimensions*

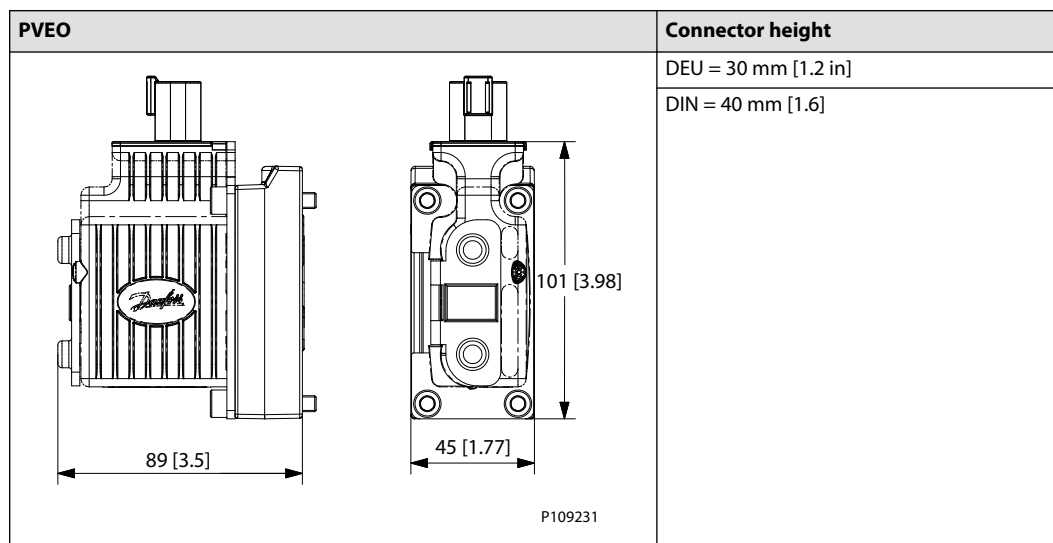

**PVEO Technical Data**

*Control Specification*

Description	Type	Value	
Supply Voltage (Udc)	Rated	12 Vdc	24 Vdc
	Range	11 to 15 Vdc	22 to 30 Vdc
	Max. ripple	5%	
<i>Current Consumption</i>	Typical	480 mA	250 mA
	Minimum	430 mA	220 mA
	Maximum	950 mA	480 mA

**PVEO**

*Operating Conditions*

Description	Type	Value	
Pilot Pressure	Nominal	13.5 bar	[196 psi]
	Minimum	10.0 bar	[145 psi]
	Maximum	15.0 bar	[218 psi]
Oil Consumption	Neutral	0.0 l/min	[0.0 gal/min]
	Locked position	0.0 l/min	[0.0 gal/min]
	Actuating	0.9 l/min	[0.24 gal/min]
	Actuating (PVEO-R)	0.3 l/min	[0.08 gal/min]
Max T-port pressure	Static	25 bar	[365 psi]
Max T-port pressure	Intermittent	40 bar	[580 psi]
Storage Temperature	Ambient	-50 to +90°C	[-58 to +194°F]
Operating Temperature	Ambient	-40 to +90°C	[-40 to +194°F]
Oil Viscosity	Operating range	12 to 75 cSt	[65 to 347 SUS]
	Minimum	4 cSt	[39 SUS]
	Maximum	460 cSt	[2128 SUS]
Oil Cleanliness	Maximum	18/16/13 (according to ISO 4406)	

*LED characteristic*

Color	LED characteristic	Description
Green constant		Power ON

**PVEO Reaction Times**

*Reaction times*

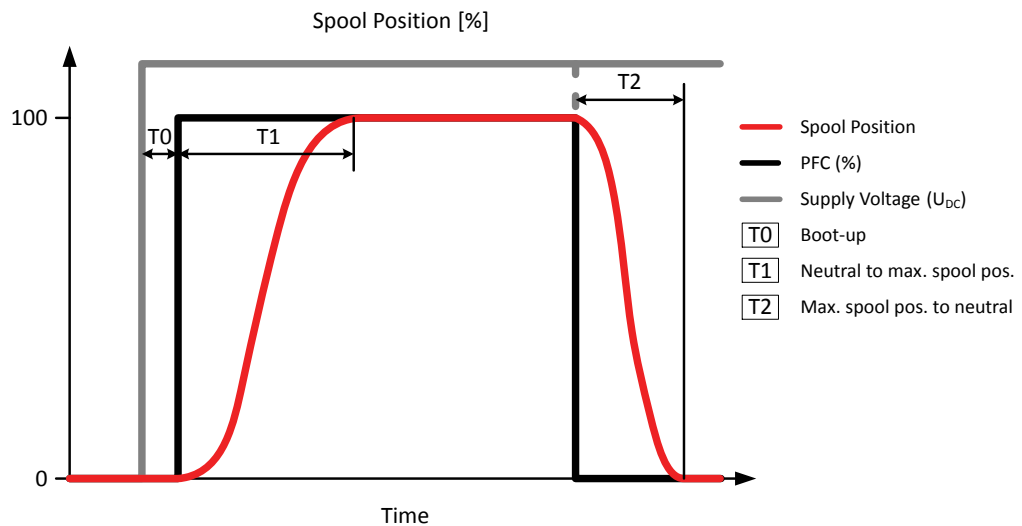

## PVEO

### Definition of Step Response

Reaction	PVG 32		PVG 128/256	
	PVEO PVEO-DI	PVEO-R	A port	B port
T0 – Boot-up	0	0	0	0
T1 – Neutral to max. spool stroke @ Power ON/ @ Constant U <sub>DC</sub>	110 ms	325 ms	375 ms	520 ms
T2 – Max. spool stroke to neutral @ Power OFF/@ Constant U <sub>DC</sub>	110 ms	340 ms	350 ms	600 ms

## PVEO Variants for PVG

### PVG 32/100 Variants

Part number	Type	Connector	IP	Udc	Functionality
11166843	PVEO	1x4 DEU	67	12 Vdc	Standard
11166838	PVEO	1x4 DEU	67	24 Vdc	Standard
11166866	PVEO	1x4 AMP	66	12 Vdc	Standard
11166837	PVEO	1x4 AMP	66	24 Vdc	Standard
11166836	PVEO	1x4 DIN	65	12 Vdc	Standard
11166743	PVEO	1x4 DIN	65	24 Vdc	Standard
11166753	PVEO-R	1x4 DEU	67	12 Vdc	Ramp
11166754	PVEO-R	1x4 DEU	67	24 Vdc	Ramp
11166867	PVEO-R	1x4 AMP	66	12 Vdc	Ramp
11166776	PVEO-R	1x4 AMP	66	24 Vdc	Ramp
11166831	PVEO-R	1x4 DIN	65	12 Vdc	Ramp
11166908	PVEO-R	1x4 DIN	65	24 Vdc	Ramp
11168740 <sup>1</sup>	PVEO-DI	2x4 AMP	66	12 Vdc	Standard
11166869 <sup>1</sup>	PVEO-DI	2x4 AMP	66	24 Vdc	Standard

<sup>1</sup> Includes *Direction Indication* special feature

### PVG 120 Variants

Part number	Type	Connector	IP	Udc	Functionality
11166755	PVEO	1x4 DEU	67	12 Vdc	Standard
11166757	PVEO	1x4 DEU	67	24 Vdc	Standard
11166815	PVEO	1x4 AMP	66	12 Vdc	Standard
11166816	PVEO	1x4 AMP	66	24 Vdc	Standard
11166822	PVEO	1x4 DIN	65	12 Vdc	Standard
11166744	PVEO	1x4 DIN	65	24 Vdc	Standard
11166882	PVEO-R	1x4 AMP	66	24 Vdc	Ramp
11166909	PVEO-R	1x4 DIN	65	24 Vdc	Ramp

### PVG 128/256 Variants

Part number	Type	Connector	IP	Udc	Functionality
11186328	PVEO	1x4 DEU	67	12 Vdc	Standard
11186330	PVEO	1x4 DEU	67	24 Vdc	Standard

## PVEO

### *PVG 128/256 Variants (continued)*

Part number	Type	Connector	IP	Udc	Functionality
11186331	PVEO	1x4 DIN	65	12 Vdc	Standard
11186342	PVEO	1x4 DIN	65	24 Vdc	Standard

### *PVG 60 Variants*

Part number	Type	Connector	IP	Udc	Functionality
11166939	PVEO	1x4 DIN	65	12 Vdc	Standard
11166940	PVEO	1x4 DIN	65	24 Vdc	Standard

## PVEO-HP

The PVEO-HP actuator is a non-proportional ON/OFF control actuator with open-loop spool control primarily used to control simple ON/OFF work functions where a proportional control of speed or oil flow is not a requirement.

### *PVEO-HP*

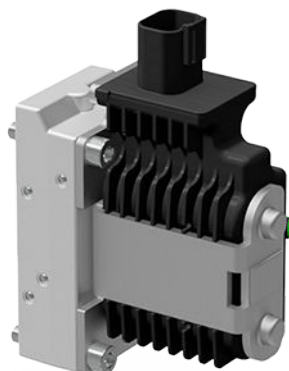

All variants are available with following features:

- Neutral position or max. spool stroke according to control signal
- 12 V<sub>DC</sub> or 24 V<sub>DC</sub> supply voltage
- DEUTSCH, AMP or DIN/Hirschman connectors
- PVH/PVHC pilot oil pressure of 25 bar [362.6 psi]
- LED only indicating Power ON or Power OFF

### *PVEO-HP functionality diagram*

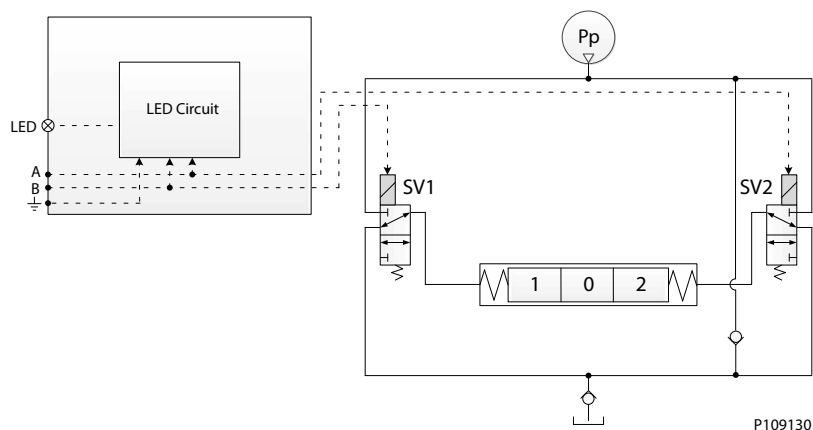

The standard PVEO/PVEO-HP functionality includes the simplest electric circuit of the PVE actuator program, using a fixed 12 V<sub>DC</sub> or 24 V<sub>DC</sub> supply voltage or signal voltage and a simple LED circuit to control the LED light indicating Power ON/OFF.

An energization of solenoid valve SV1 and a simultaneous de-energization of SV2 will cause the main spool to move to the right direction and vice versa. If both SV1 and SV2 are energized or de-energized simultaneously, the main spool stays locked in its neutral position.

**PVEO-HP**

**PVEO-HP Schematics and Dimensions**

*Schematics*

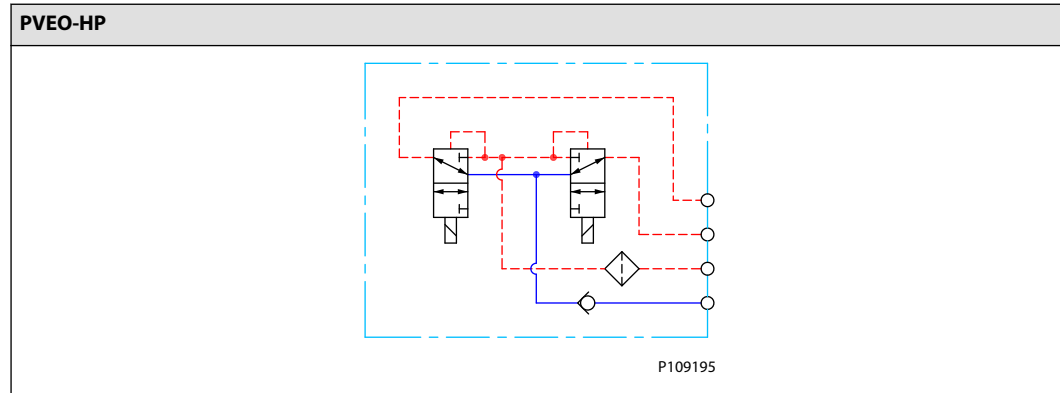

*Dimensions*

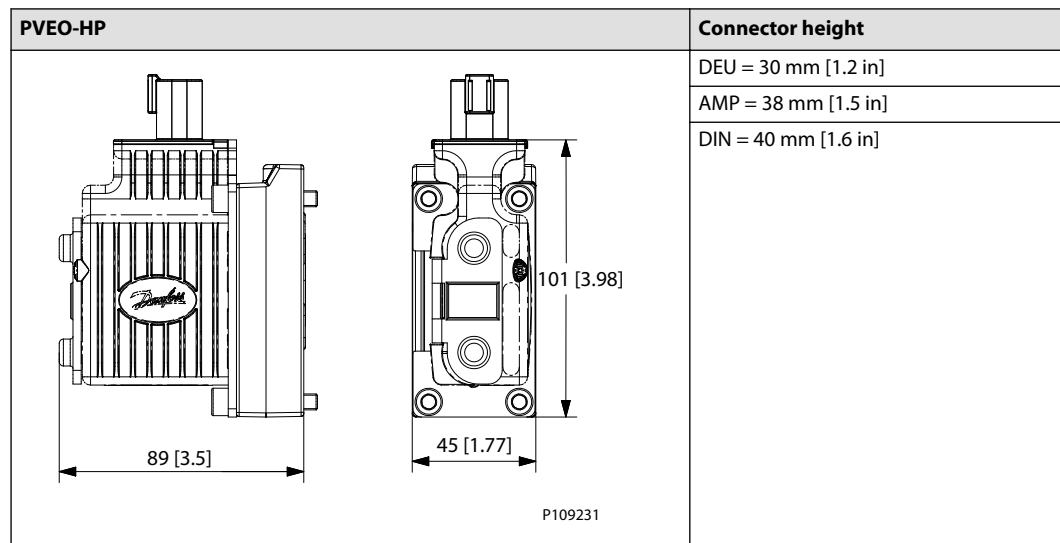

For more information on dimensions, please see [Dimension Overview for PVE Series 7](#) on page 59.

**PVEO-HP Technical Data**

*Control Specification*

Description	Type	12 V <sub>DC</sub>	24 V <sub>DC</sub>
Supply Voltage (U <sub>DC</sub> )	Range	11 to 15 V <sub>DC</sub>	22 to 30 V <sub>DC</sub>
	Max. ripple	5%	
Current Consumption	Typical	750 mA	380 mA
	Minimum	660 mA	340 mA
	Maximum	1460 mA	740 mA



**PVEO-HP**

*Technical data*

<b>Pilot pressure</b>	Nominal	25 bar [363 psi]
	Minimum	21 bar [305 psi]
	Maximum	25 bar [363 psi]
<b>Fluid consumption</b>	Neutral	0 l/min [0 US gal/min]
	Locked position	0 l/min [0 US gal/min]
	Actuating	0.9 l/min [0.24 US gal/min]

*Technical specification*

Parameter	Minimum	Recommended range	Maximum
<b>Fluid temperature</b>	-30°C [-22°F]	30 to 60°C [86 to 140°F]	90° [194°F]
<b>Fluid viscosity</b>	4 mm <sup>2</sup> /s [39 SUS]	12 to 75 mm <sup>2</sup> /s [65 to 347 SUS]	460 mm <sup>2</sup> /s [2128 SUS]
<b>Fluid cleanliness</b>	23/19/16 (according to ISO 4406)		
<b>Operating temperature</b>	Ambient: -30 to 60°C [-22 to 140°F]		
<b>Max. T-port pressure (static)</b>	25 bar [365 psi]		
<b>Max T-port pressure (static)</b>	40 bar [ 580 psi]		

*LED characteristic*

Color	LED characteristic	Description
Green constant		Power ON

**PVEO-HP Reaction Times**

*Reaction times*

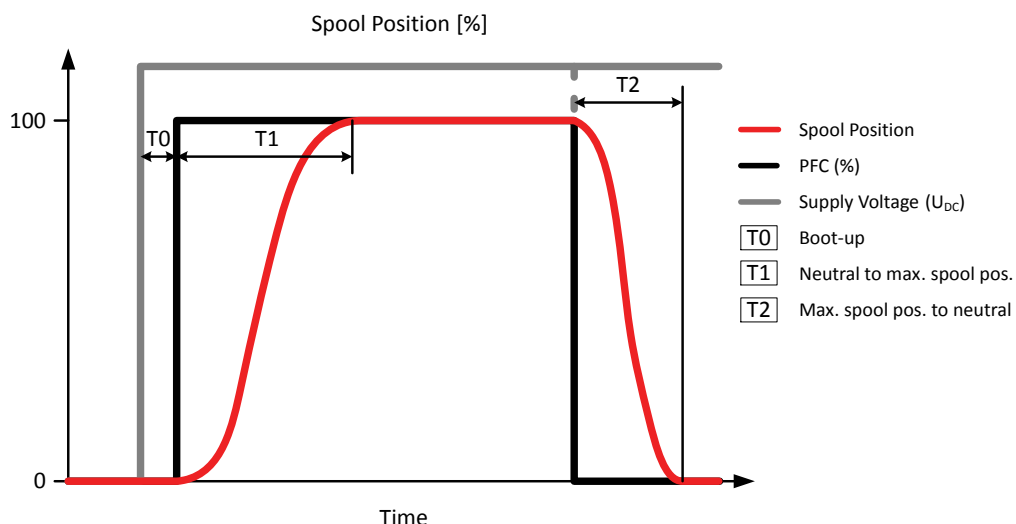

**PVEO-HP**

*Definition of Step Response*

Reaction	PVEO-HP
T0 – Boot-up	0
T1 – Neutral to max. spool stroke @ Power ON/@ Constant U <sub>DC</sub>	90 ms
T2 – Max. spool stroke to neutral @ Power OFF/@ Constant U <sub>DC</sub>	70 ms

**PVEO-HP Variants for PVG**

*PVG 32/100 variants*

Part number	Type	Connector	IP	U <sub>dc</sub>	Functionality
11166765	PVEO-HP	1x4 DEU	67	12 Vdc	Standard
11166766	PVEO-HP	1x4 DEU	67	24 Vdc	Standard
11166763	PVEO-HP	1x4 AMP	66	12 Vdc	Standard
11187524	PVEO-HP	1x4 AMP	66	24 Vdc	Standard
11187551	PVEO-HP	1x4 DIN	65	12 Vdc	Standard
11187562	PVEO-HP	1x4 DIN	65	24 Vdc	Standard

## PVEM

The PVEM actuator is a proportional control actuator with closed-loop spool control primarily used to control work functions with medium performance requirements. The PVEM is available in three different performance variants, the standard PVEM, the PVEM-R with ramp and the PVEM-Q with quick reaction.

### PVEM

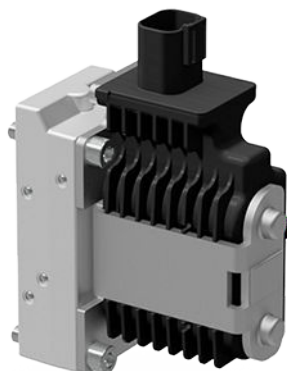

Variants are available with following features:

- 11-32 V<sub>DC</sub> multi-voltage power supply
- Analog voltage control signal 25–75% of supply voltage
- DIN/Hirschman connectors
- Standard PVE pilot oil pressure of 13.5 bar [196 psi]
- LED indicating error state and passive fault monitoring
- Float (-F), quick Ramp (-R) or Quick reaction functionality (-Q)

### PVEM functionality

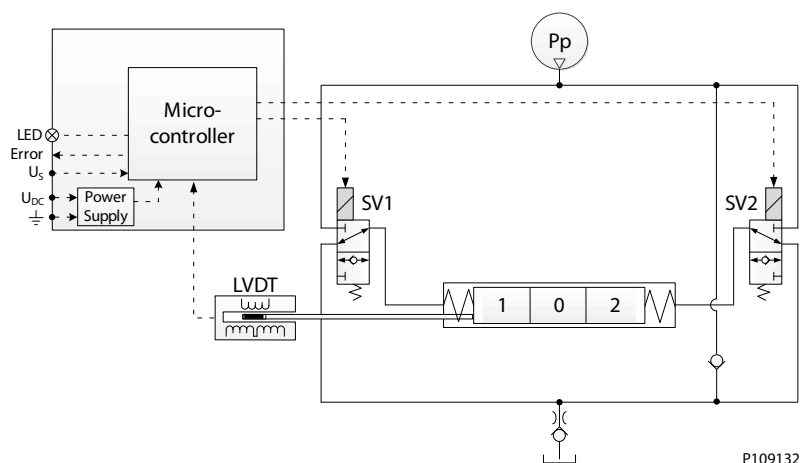

The PVE functionality includes an electric circuit with a closed-loop logic. An embedded micro-controller processes the signal voltage and the LVDT feedback signal and regulates the solenoid valves accordingly.

An energization of solenoid valve SV1 and a simultaneous de-energization of SV2 will cause the main spool to move to the right direction and vice versa. If both SV1 and SV2 are energized or de-energized simultaneously, the main spool stays locked in its neutral position.

**PVEM**

**PVEM Schematics and Dimensions**

*Schematics*

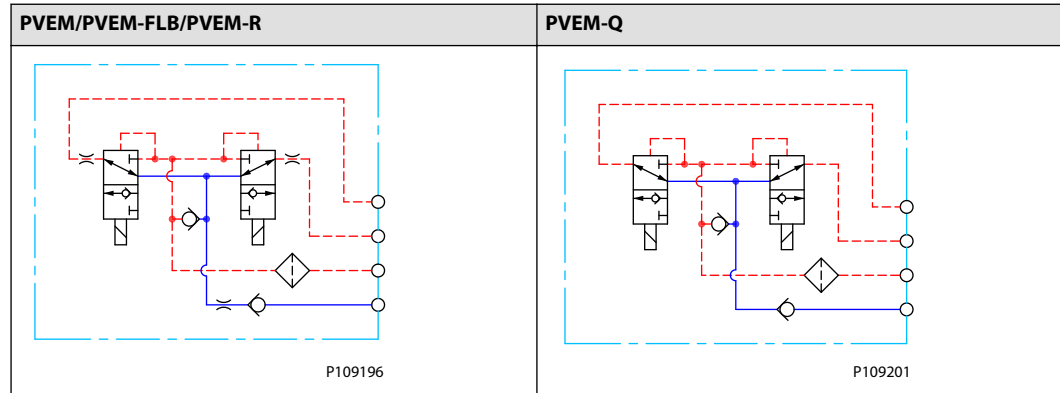

*Dimensions*

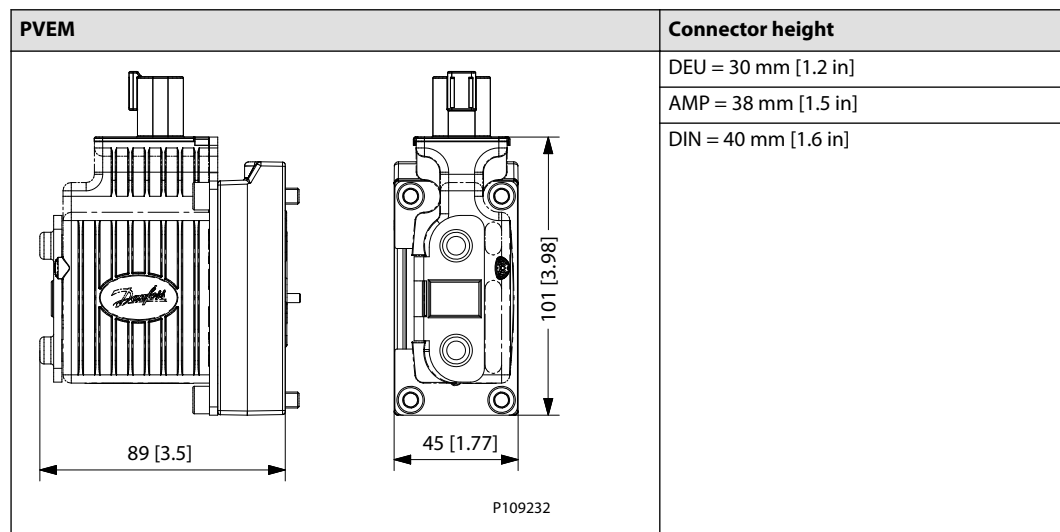

For more information on dimensions, please see [Dimension Overview for PVE Series 7](#) on page 59.

**PVEM Technical Data**

*Control Specification*

Description	Type	Value
Supply Voltage ( $U_{DC}$ )	Rated Range	11 to 32 V <sub>DC</sub>
	Max. ripple	5%
Signal Voltage PWM ( $U_S$ )	Neutral	$U_S = 0.5 U_{DC} = 50\%$ DUT
	Q: P to A	$U_S = (0.5 \text{ to } 0.25) U_{DC} = 50\%$ to 25% DUT
	Q: P to B	$U_S = (0.5 \text{ to } 0.75) U_{DC} = 50\%$ to 75% DUT
Input Impedance	Rated	12 k $\Omega$
Input Capacitance	Rated	100 nF

## PVEM

### Current consumption

Description	@ 12 V <sub>DC</sub>	@ 24 V <sub>DC</sub>
PWM Frequency (U <sub>s</sub> ) recommended	> 200 Hz	> 200 Hz
Current Consumption	690 mA	350 mA

### Pilot pressure

Minimum	Nominal	Maximum
10.0 bar [145 psi]	13.5 bar [196 psi]	15.0 bar [218 psi]

### Fluid consumption

Neutral/Locked position	Actuating (PVEM-R)	Actuating (PVEM-Q)	Actuating
0 l/min	0.3 l/min	1.0 l/min [0.26 US gal/min][0.08 US gal/min]	0.5 l/min [0.13 US gal/min]

### Technical specification

Parameter	Minimum	Recommended range	Maximum
Fluid temperature	-30°C [-22°F]	30 to 60°C [86 to 140°F]	90° [194°F]
Fluid viscosity	4 mm <sup>2</sup> /s [39 SUS]	12 to 75 mm <sup>2</sup> /s [65 to 347 SUS]	460 mm <sup>2</sup> /s [2128 SUS]
Fluid cleanliness	23/19/16 (according to ISO 4406)		
Operating temperature	Ambient: -30 to 60°C [-22 to 140°F]		
Max. T-port pressure static / intermittent	25 / 40 bar [365 / 580 psi]		

### LED characteristic

Color	LED characteristic	Description
Green constant		No error – Actuating
Green flashing @ 1.5 Hz		Neutral – Power save
Red constant		Internal error
Red flashing @ 1.5 Hz		External or Float error

**PVEM**

**PVEM Reaction Times**

Reaction times

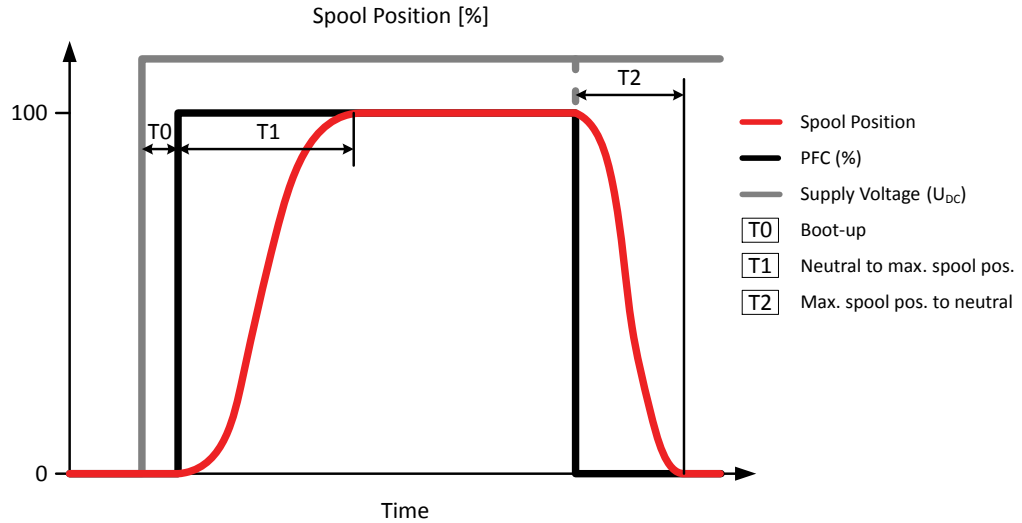

P301823

Definition of Step Response

Reaction	PVEM-R	PVEM-FLB	PVEM-Q
T0 – Boot-up	15 ms	15 ms	15 ms
T1 – Neutral to max. spool stroke @ Power ON	325 ms	225 ms	125 ms
T2 – Max. spool stroke to neutral @ Power OFF	110 ms	110 ms	110 ms
T1 – Neutral to max. spool stroke @ Constant $U_{DC}$	310 ms	210 ms	110 ms
T2 – Max. spool stroke to neutral @ Constant $U_{DC}$	90 ms	90 ms	90 ms

**PVEM Hysteresis and Ripple**

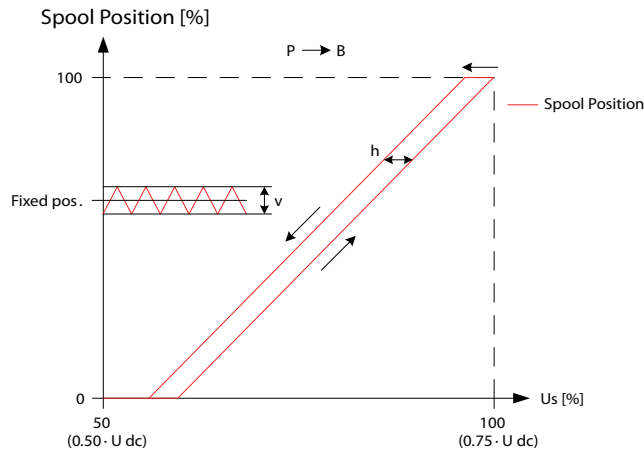

Description	Type	PVEM
Hysteresis (h)	Rated [%]	15
Steady state ripple @ fixed $U_s$ (v)	Rated [mm]	0.0

For more information on hysteresis and ripple, see [Hysteresis and Ripple](#).

**PVEM**

**PVEM Variants for PVG**

*PVG 32/100 Variants*

<b>Part number</b>	<b>Type</b>	<b>Connector</b>	<b>IP</b>	<b>Fault Monitoring</b>	<b>Functionality</b>
11166829	PVEM	1x4 DIN	65	Passive	Standard
11166852	PVEM-FLB	1x4 DIN	65	Passive	Float B-port
11166845	PVEM-R	1x4 DIN	65	Passive	Ramp
11166853	PVEM-Q	1x4 DIN	65	Passive	Quick Reaction

**PVEA**

The PVEA actuator is a proportional control actuator with a closed-loop spool control primarily used to control work functions with above medium performance requirements.

*PVEA*

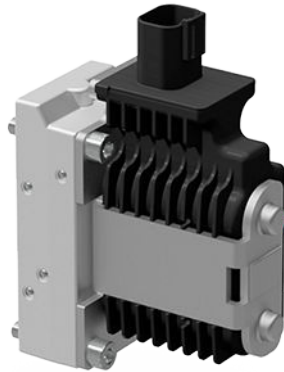

- 11-32 V<sub>DC</sub> multi-voltage power supply
- Analog voltage control signal 25–75% of supply voltage
- Standard PVE pilot oil pressure of 13.5 bar [196 psi]
- DEUTSCH or AMP connectors
- LED indicating error state and active or passive fault monitoring
- Direction Indication output (-DI) or Neutral Power-Off (-NP) functionality

**PVEA-DI functionality**

*PVEA-DI functionality*

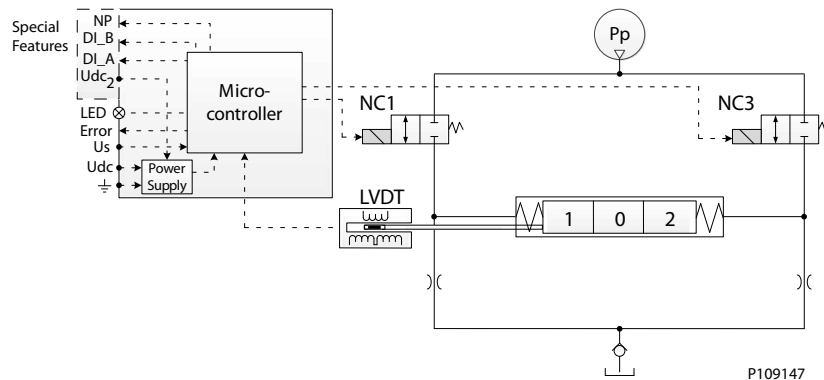

The PVE functionality includes an electric circuit with a closed-loop logic. An embedded micro-controller processes the signal voltage and the LVDT feedback signal and regulates the solenoid valves accordingly.

A continuous modulation of solenoid valve NC1 and a simultaneous de-energization of NC3 causes the main spool to move to the right direction and vice versa. When the main spool is stroked to the far right, a simultaneous modulation of both NC1 and NC3 balances the main spool in its stroked position. The main spool oscillates in its stroked position at a frequency corresponding to the modulation frequency. When both NC1 and NC3 are de-energized, the main spool moves back to its neutral position by means of the main spool neutral spring and the hydraulic principle.



## PVEA

### PVEA Schematics and Dimensions

#### Schematics

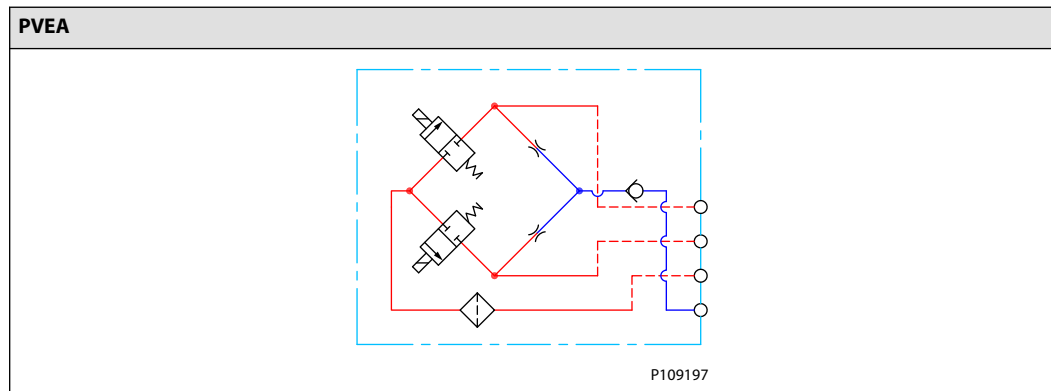

#### Dimensions

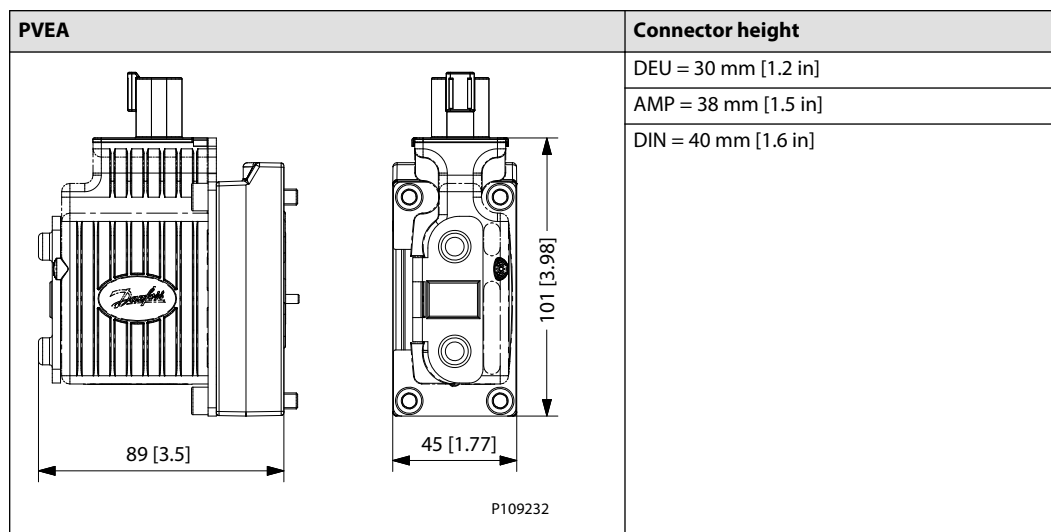

For more information on dimensions, see [Dimension Overview for PVE Series 7](#) on page 59.

### PVEA Technical Data

#### Control Specification

Description	Type	Value
Supply Voltage ( $U_{DC}$ )	Rated Range	11 to 32 $V_{DC}$
	Max. ripple	5%
Signal Voltage PWM ( $U_S$ )	Neutral	$U_S = 0.5 U_{DC} = 50\%$ DUT
	Q: P to A	$U_S = (0.5 \text{ to } 0.25) U_{DC} = 50\%$ to 25% DUT
	Q: P to B	$U_S = (0.5 \text{ to } 0.75) U_{DC} = 50\%$ to 75% DUT
Input Impedance	Rated	12 $k\Omega$
Input Capacitance	Rated	100 nF

**PVEA**

*Current consumption*

Description	@ 12 V <sub>DC</sub>	@ 24 V <sub>DC</sub>
PWM Frequency (U <sub>S</sub> ) recommended	> 1000 Hz	> 1000 Hz
Current Consumption	290 mA	150 mA

*Pilot pressure*

Minimum	Nominal	Maximum
10.0 bar [145 psi]	13.5 bar [196 psi]	15.0 bar [218 psi]





*Fluid consumption*

Neutral	Locked position	Actuating
0 l/min	0 l/min	1.0 l/min [0.26 US gal/min]

*Technical specification*

Parameter	Minimum	Recommended range	Maximum
<b>Fluid viscosity</b>	4 mm <sup>2</sup> /s [39 SUS]	12 to 75 mm <sup>2</sup> /s [65 to 347 SUS]	460 mm <sup>2</sup> /s [2128 SUS]
<b>Fluid cleanliness</b>	18/16/13 (according to ISO 4406)		
<b>Storage temperature</b>	Ambient: -50 to 90°C [-58 to 194°F]		
<b>Operating temperature</b>	Ambient: -30 to 60°C [-22 to 140°F]		
<b>Max. T-port pressure static / intermittent</b>	25 / 40 bar [365 / 580 psi]		

*LED characteristic*

Color	LED characteristic	Description
Green constant		No error – Actuating
Green flashing @ 1.5 Hz		Neutral – Power save
Red constant		Internal error
Red flashing @ 1.5 Hz		External or Float error

## PVEA

### PVEA Reaction Times

Reaction times

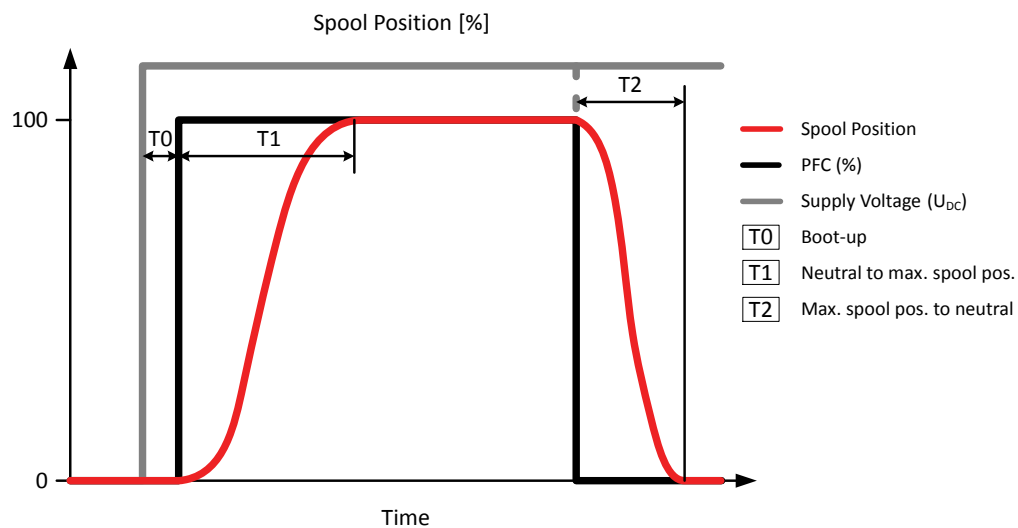

P301823

Reaction	PVG 32 (PVEA)
T0 – Boot-up [ms]	50 ms
T1 – Neutral to max. spool stroke @ Power ON	355 ms
T2 – Max. spool stroke to neutral @ Power OFF	260 ms
T1 – Neutral to max. spool stroke @ Constant $U_{DC}$	305 ms
T2 – Max. spool stroke to neutral @ Constant $U_{DC}$	210 ms

### PVEA Hysteresis and Ripple

Spool position vs. supply (%)

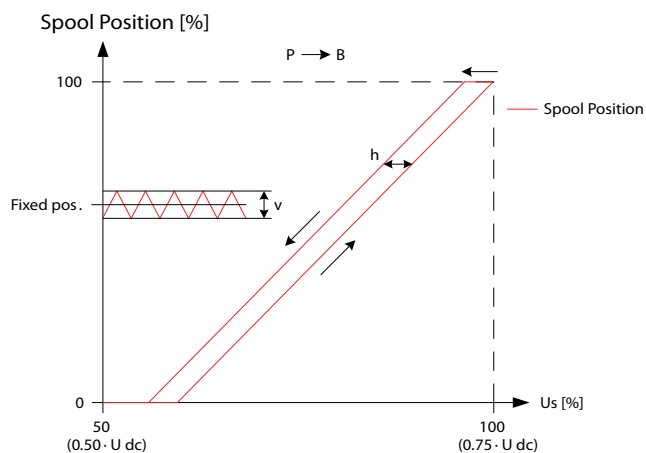

Description	Type	PVEA
Hysteresis (h)	Rated [%]	2
Steady state ripple @ fixed $U_s$ (v)	Rated [mm]	0.3

For more information on hysteresis and ripple, see [Hysteresis and Ripple](#).

**PVEA**

**PVEA Variants for PVG**

*PVG 32/100 Variants*

<b>Part number</b>	<b>Type</b>	<b>Connector</b>	<b>IP</b>	<b>Fault monitoring</b>	<b>Functionality</b>
11177346	PVEA	1x4 DEU	67	Passive	Standard
11177347	PVEA	1x4 DEU	67	Active	Standard
11177353	PVEA	1x4 AMP	66	Passive	Standard
11177348	PVEA	1x4 AMP	66	Active	Standard
11177345 <sup>1</sup>	PVEA-NP	1x6 DEU	67	Active	Standard
11177357 <sup>2</sup>	PVEA-DI	2x4 DEU	67	Active	Standard
11177356 <sup>2</sup>	PVEA-DI	2x4 AMP	66	Passive	Standard
11177355 <sup>2</sup>	PVEA-DI	2x4 AMP	66	Active	Standard

<sup>1</sup> Includes *Neutral Power-OFF* special feature

<sup>2</sup> Includes *Direction Indication* special feature

## PVEH

The PVEH actuator is a proportional control actuator with closed-loop spool control primarily used to control work functions with high performance requirements.

### PVEH

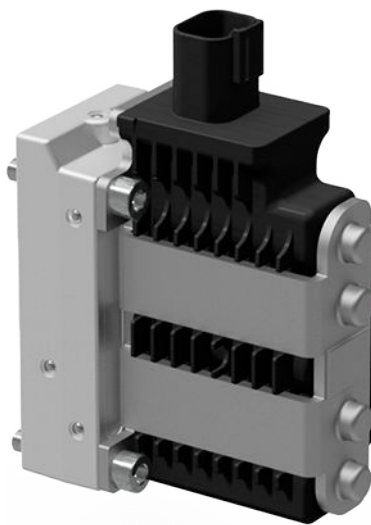

- 11-32 V<sub>DC</sub> multi-voltage power supply
- Analog voltage control signal 25–75% of supply voltage
- Standard PVE pilot oil pressure of 13.5 bar [196 psi]
- DEUTSCH, AMP or DIN/Hirschman connectors
- LED indicating error state and active or passive fault monitoring
- Float (-F), Direction Indication output (-DI), Neutral Power-Off (-NP), Spool Position output (-SP) or 0-10 V<sub>DC</sub> control signal (-U) functionality

### PVEH functionality

#### PVEH functionality

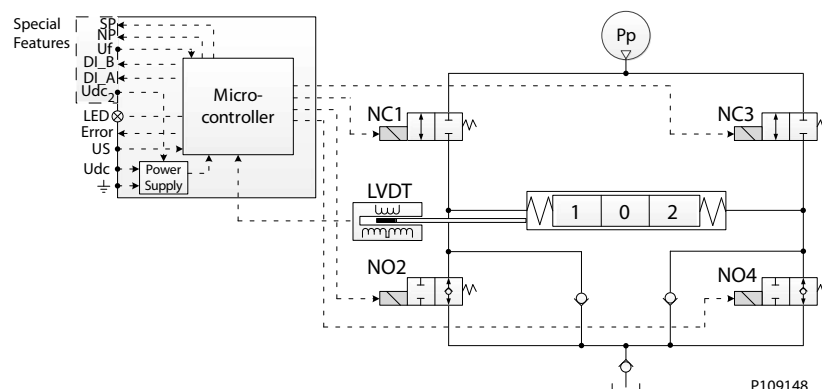

The PVE functionality includes an electric circuit with a closed-loop logic. An embedded micro-controller processes the signal voltage and the LVDT feedback signal and regulates the solenoid valves accordingly.

A continuous modulation of solenoid valves NC1 and NO4 together with a simultaneous energization of NO2 and de-energization of NC3 causes the main spool to move to the right direction and vice versa. When the main spool is stroked to the far right, a simultaneous energization of both NO2 and NO4 and de-energization of both NC1 and NC3 balances the main spool in its stroked position. An emergency stop activated when the spool is stroked will cause all solenoid valves to de-energize causing the main spool

**PVEH**

to move back to its neutral position by means of the main spool neutral spring and the hydraulic principle.

**PVEH Schematics and Dimensions**

*Schematics*

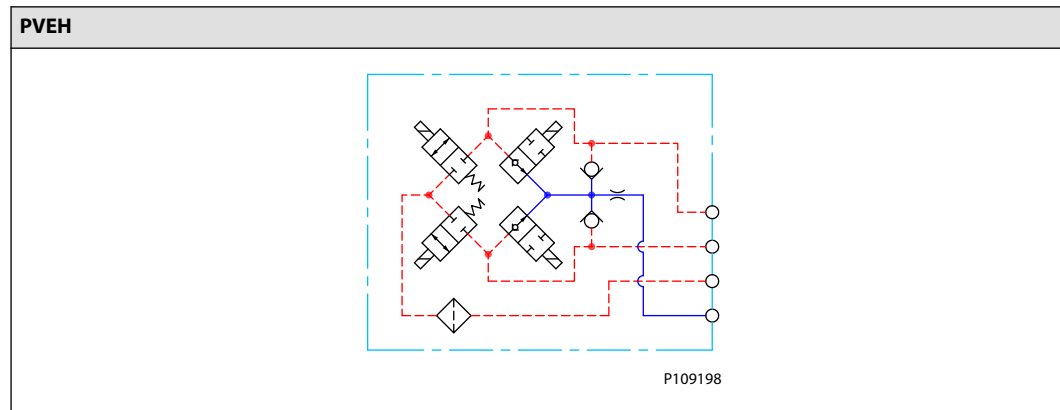

*Dimensions*

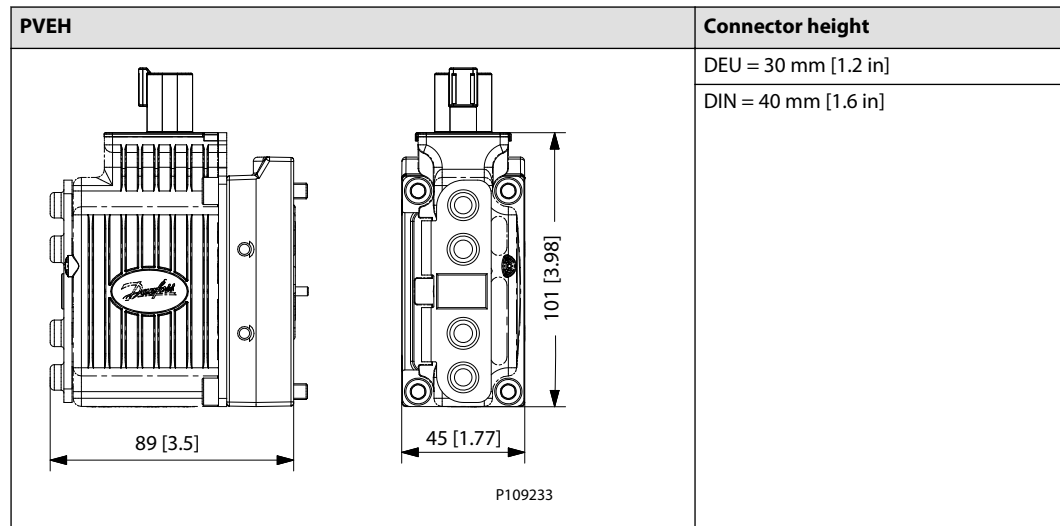

**PVEH Technical Data**

*Control Specification*

Description	Type	Value
Supply Voltage ( $U_{DC}$ )	Rated Range	11 to 32 V <sub>DC</sub>
	Max. ripple	5%
Signal Voltage PWM ( $U_S$ )	Neutral	$U_S = 0.5 U_{DC} = 50\%$ DUT
	Q: P to A	$U_S = (0.5 \text{ to } 0.25) U_{DC} = 50\%$ to 25% DUT
	Q: P to B	$U_S = (0.5 \text{ to } 0.75) U_{DC} = 50\%$ to 75% DUT
Input Impedance	Rated	12 k $\Omega$
Input Capacitance	Rated	100 nF

**PVEH**

*Current consumption*

Description	@ 12 V <sub>DC</sub>	@ 24 V <sub>DC</sub>
PWM Frequency (U <sub>s</sub> ) recommended	> 1000 Hz	> 1000 Hz
Current Consumption	540 mA	270 mA
Max. DI Current	200 mA	200 mA

*Pilot pressure*

Minimum	Nominal	Maximum
10.0 bar [145 psi]	13.5 bar [196 psi]	15.0 bar [218 psi]

*Fluid consumption*

Neutral	Locked position	Actuating
0.0 l/min	0.0 l/min	0.7 l/min [0.18 US gal/min]

*Technical specification*

Parameter	Minimum	Recommended range	Maximum
<b>Fluid viscosity</b>	4 mm <sup>2</sup> /s [39 SUS]	12 to 75 mm <sup>2</sup> /s [65 to 347 SUS]	460 mm <sup>2</sup> /s [2128 SUS]
<b>Fluid cleanliness</b>	18/16/13 (according to ISO 4406)		
<b>Storage temperature</b>	Ambient: -50 to 90°C [-58 to 194°F]		
<b>Operating temperature</b>	Ambient: -30 to 60°C [-22 to 140°F]		
<b>Max. T-port pressure static / intermittent</b>	25 / 40 bar [365 / 580 psi]		

*LED Characteristic*

Color	LED Characteristic	Description
Green constant		No error – Actuating
Green flashing @ 1.5 Hz		Neutral – Power save
Red constant		Internal error
Red flashing @ 1.5 Hz		External or Float error
Yellow		Disable mode

**PVEH**

**PVEH Reaction Times**

Reaction times

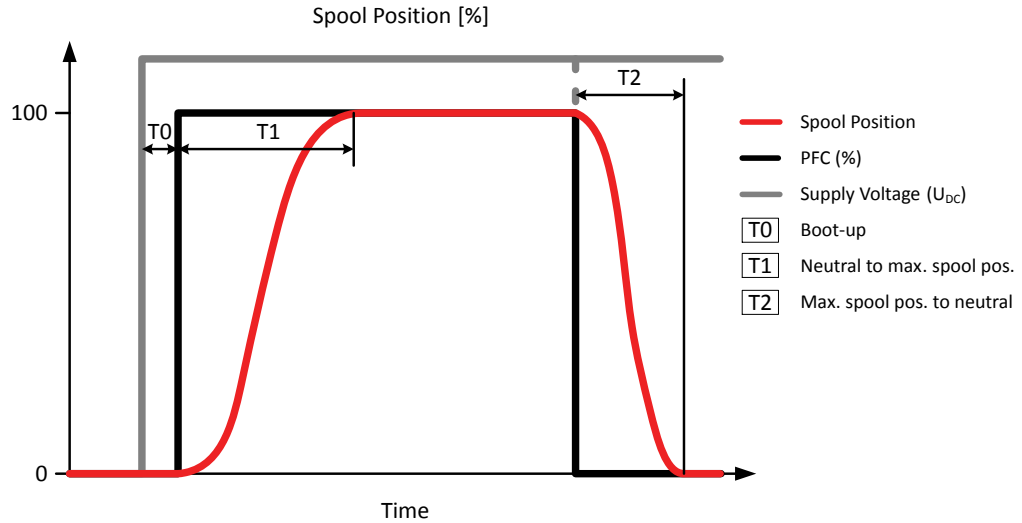

P301823

Reaction	PVG 32	PVG 128/256
T0 – Boot-up [ms]	40 ms	80 ms
T1 – Neutral to max. spool stroke @ Power ON [ms]	155 ms	400 ms
T2 – Max. spool stroke to neutral @ Power OFF [ms]	130 ms	300 ms
T1 – Neutral to max. spool stroke @ Constant $U_{DC}$ [ms]	115 ms	380 ms
T2 – Max. spool stroke to neutral @ Constant $U_{DC}$ [ms]	90 ms	270 ms

**PVEH Hysteresis and Ripple**

Spool position vs. supply (%)

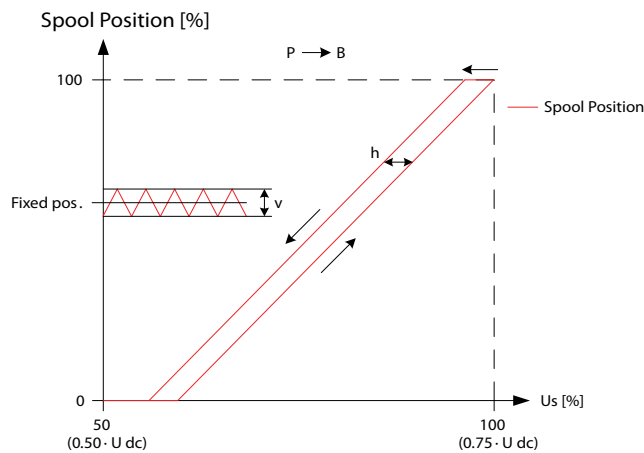

Description	Type	PVEH
Hysteresis (h)	Rated [%]	4
Steady state ripple @ fixed $U_s$ (v)	Rated [mm]	0.0



**PVEH**

**PVEH Variants for PVG**

*PVG 32/100 variants*

Part number	Type	Connector	IP	Fault monitoring	Functionality
11166732	PVEH	1x4 DEU	67	Passive	Standard
11166775	PVEH	1x4 DEU	67	Active	Standard
11166825	PVEH	1x4 AMP	66	Passive	Standard
11166818	PVEH	1x4 AMP	66	Active	Standard
11166824	PVEH	1x4 DIN	65	Passive	Standard
11166817	PVEH	1x4 DIN	65	Active	Standard
11166832 <sup>1</sup>	PVEH-U	1x4 AMP	66	Passive	Fixed US 0-10 V dc
11166821 <sup>1</sup>	PVEH-U	1x4 AMP	66	Active	Fixed US 0-10 V dc
11166770 <sup>1</sup>	PVEH-U	1x4 DIN	65	Passive	Fixed US 0-10 V dc
11166772 <sup>1</sup>	PVEH-U	1x4 DIN	65	Active	Fixed US 0-10 V dc
11166840	PVEH-FLB	1x4 DEU	67	Passive	Float B-port
11166742	PVEH-FLB	1x4 DEU	67	Active	Float B-port
11166839	PVEH-FLB	1x4 DIN	65	Active	Float B-port
11166841 <sup>2</sup>	PVEH-FLA	1x6 DEU	67	Active	Float A-port
11168738 <sup>2</sup>	PVEH-FLA	1x6 AMP	66	Passive	Float A-port
11168739 <sup>2</sup>	PVEH-FLA	1x6 AMP	66	Active	Float A-port
11166773 <sup>3</sup>	PVEH-SP	1x6 DEU	67	Active	Standard
11166750 <sup>4</sup>	PVEH-NP	1x6 DEU	67	Fast active	Standard
11166835 <sup>5</sup>	PVEH-DI	2x4 DEU	67	Active	Standard
11166820 <sup>5</sup>	PVEH-DI	2x4 AMP	66	Passive	Standard
11166819 <sup>5</sup>	PVEH-DI	2x4 AMP	66	Active	Standard

- <sup>1</sup> Includes *Disable Mode* special feature
- <sup>2</sup> Includes *Dedicated Float Pin (UF)* special feature
- <sup>3</sup> Includes *Spool Position* special feature
- <sup>4</sup> Includes *Neutral Power-Off* special feature
- <sup>5</sup> Includes *Direction Indication* special feature

*PVG 120 variants*

Part number	Type	Connector	IP	Fault monitoring	Functionality
11166760	PVEH	1x4 DEU	67	Passive	Standard
11166814	PVEH	1x4 AMP	66	Passive	Standard
11166801	PVEH	1x4 AMP	66	Active	Standard
11166813	PVEH	1x4 DIN	65	Passive	Standard
11166777	PVEH	1x4 DIN	65	Active	Standard
11166771 <sup>1</sup>	PVEH-U	1x4 DIN	65	Passive	Fixed US 0-10 V dc
11166767 <sup>1</sup>	PVEH-U	1x4 DIN	65	Active	Fixed US 0-10 V dc

- <sup>1</sup> Includes *Disable Mode* special feature

**PVEH**

*PVG 128/256 variants*

<b>Part number</b>	<b>Type</b>	<b>Connector</b>	<b>IP</b>	<b>Fault monitoring</b>	<b>Functionality</b>
11186325	PVEH	1x4 DEU	67	Passive	Standard
11186326	PVEH	1x4 DEU	67	Active	Standard
11186321	PVEH	1x4 DIN	65	Passive	Standard
11186322	PVEH	1x4 DIN	65	Active	Standard
11186323 <sup>1</sup>	PVEH-U	1x4 DIN	65	Passive	Fixed US 0-10 Vdc
11186324 <sup>1</sup>	PVEH-U	1x4 DIN	65	Active	Fixed US 0-10 Vdc

<sup>1</sup> Includes *Disable Mode* special feature

*PVG 60 variants*

<b>Part number</b>	<b>Type</b>	<b>Connector</b>	<b>IP</b>	<b>Fault monitoring</b>	<b>Functionality</b>
11166910	PVEH	1x4 DIN	65	Active	Float B-port

## PVES

The PVES actuator is a proportional control actuator with closed-loop spool control primarily used to control work functions with very high performance requirements.

### PVES

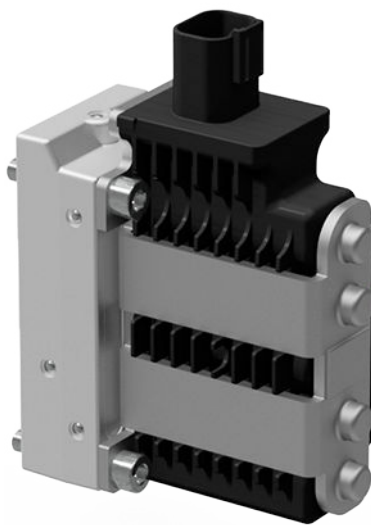

- 11-32 V<sub>DC</sub> multi-voltage power supply
- Analog voltage control signal 25–75% of supply voltage
- Standard PVE pilot oil pressure of 13.5 bar [196 psi]
- DEUTSCH, AMP or DIN/Hirschman connectors
- LED indicating error state and active or passive fault monitoring
- Spool Position output (-SP) or 0-10 V<sub>DC</sub> control signal (-U) functionality

### PVES functionality

#### PVES functionality

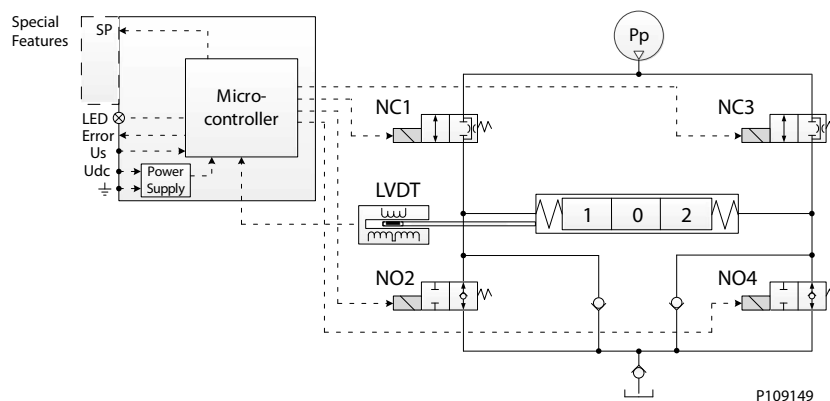

The PVE functionality includes an electric circuit with a closed-loop logic. An embedded micro-controller processes the signal voltage and the LVDT feedback signal and regulates the solenoid valves accordingly.

A continuous modulation of solenoid valves NC1 and NO4 together with a simultaneous energization of NO2 and de-energization of NC3 causes the main spool to move to the right direction and vice versa. When the main spool is stroked to the far right, a simultaneous energization of both NO2 and NO4 and de-energization of both NC1 and NC3 balances the main spool in its stroked position. An emergency stop activated when the spool is stroked will cause all solenoid valves to de-energize causing the main spool

**PVES**

to move back to its neutral position by means of the main spool neutral spring and the hydraulic principle.

**PVES Schematics and Dimensions**

*Schematic*

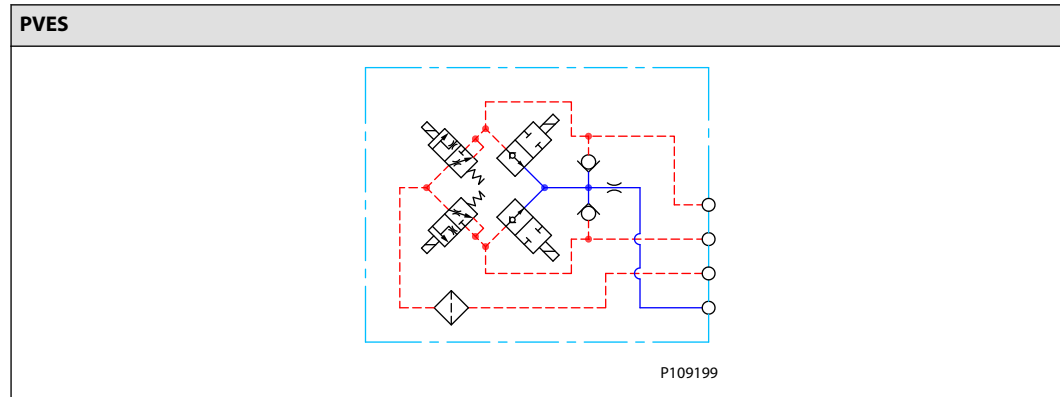

*Dimensions*

PVES		Connector height
		DEU = 30 mm [1.2 in]
		AMP = 38 mm [1.5 in]
		DIN = 40 mm [1.6 in]
P109235		

For information on dimensions, see [Dimension Overview for PVE Series 7](#) on page 59.

**PVES Technical Data**

*Control Specification*

Description	Type	Value
Supply Voltage ( $U_{DC}$ )	Rated Range	11 to 32 $V_{DC}$
	Max. ripple	5%
Signal Voltage PWM ( $U_S$ )	Neutral	$U_S = 0.5 U_{DC} = 50\%$ DUT
	Q: P to A	$U_S = (0.5 \text{ to } 0.25) U_{DC} = 50\% \text{ to } 25\%$ DUT
	Q: P to B	$U_S = (0.5 \text{ to } 0.75) U_{DC} = 50\% \text{ to } 75\%$ DUT

**PVES**

*Control Specification (continued)*

Description	Type	Value
Input Impedance	Rated	12 kΩ
Input Capacitance	Rated	100 nF

*Current consumption*

Description	@ 12 V <sub>DC</sub>	@ 24 V <sub>DC</sub>
PWM Frequency (U <sub>s</sub> ) recommended	> 1000 Hz	> 1000 Hz
Current Consumption	560 mA	280 mA

*Pilot pressure*

Minimum	Nominal	Maximum
10.0 bar [145 psi]	13.5 bar [196 psi]	15.0 bar [218 psi]

*Fluid consumption*

Neutral	Locked position	Actuating
0.03 l/min [0.106 US gal/min]	0.01 l/min [0.026 US gal/min]	0.8 l/min [0.21 US gal/min]

*Technical specification*

Parameter	Minimum	Recommended range	Maximum
<b>Fluid viscosity</b>	4 mm <sup>2</sup> /s [39 SUS]	12 to 75 mm <sup>2</sup> /s [65 to 347 SUS]	460 mm <sup>2</sup> /s [2128 SUS]
<b>Fluid cleanliness</b>	18/16/13 (according to ISO 4406)		
<b>Storage temperature</b>	Ambient: -50 to 90°C [-58 to 194°F]		
<b>Operating temperature</b>	Ambient: -30 to 60°C [-22 to 140°F]		
<b>Max. T-port pressure static / intermittent</b>	25 / 40 bar 265 / 580 psi		

*LED Characteristic*

Color	LED Characteristic	Description
Green constant		No error – Actuating
Green flashing @ 1.5 Hz		Neutral – Power save
Red constant		Internal error
Red flashing @ 1.5 Hz		External or Float error
Yellow		Disable mode

**PVES**

**PVES Reaction Times**

Reaction times

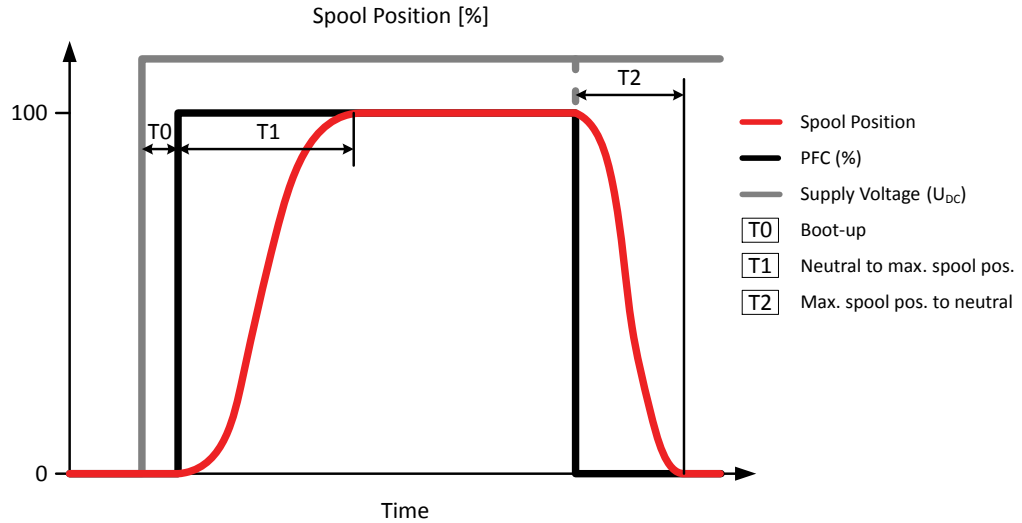

P301823

Reaction	PVES
T <sub>0</sub> – Boot-up [ms]	45 ms
T <sub>1</sub> – Neutral to max. spool stroke @ Power ON	170 ms
T <sub>2</sub> – Max. spool stroke to neutral @ Power OFF	135 ms
T <sub>1</sub> – Neutral to max. spool stroke @ Constant U <sub>DC</sub>	125 ms
T <sub>2</sub> – Max. spool stroke to neutral @ Constant U <sub>DC</sub>	90 ms

**PVES Hysteresis and Ripple**

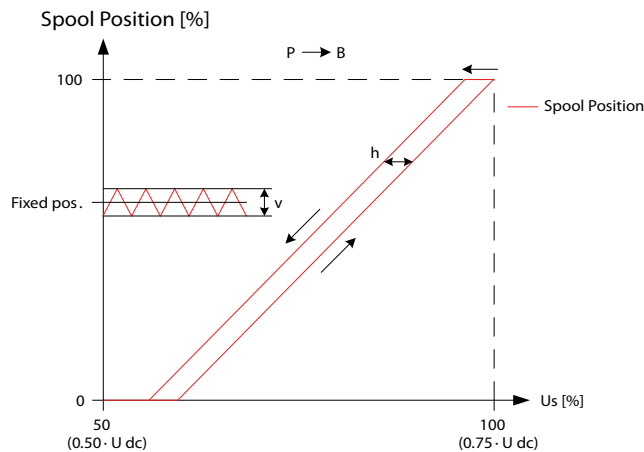

Description	Type	PVES
Hysteresis (h)	Rated [%]	<0.5
Steady state ripple @ fixed US (v)	Rated [mm]	0.2

The stated values are preliminary values and can be subject to change once an increased statistical basis is achieved.

For more information on hysteresis and ripple, see [Hysteresis and Ripple](#).

## PVES

### PVES Variants for PVG

#### *PVG 32/100 variants*

<b>Part number</b>	<b>Type</b>	<b>Connector</b>	<b>IP</b>	<b>Fault monitoring</b>	<b>Functionality</b>
11166748	PVES	1x4 DEU	67	Passive	Standard
11166864	PVES	1x4 DEU	67	Active	Standard
11166859	PVES	1x4 AMP	66	Passive	Standard
11166858	PVES	1x4 AMP	66	Active	Standard
11166849	PVES	1x4 DIN	65	Passive	Standard
11166857	PVES	1x4 DIN	65	Active	Standard
11166745 <sup>1</sup>	PVES-U	1x4 DEU	67	Passive	Fixed Us 0-10 Vdc
11166747 <sup>1</sup>	PVES-U	1x4 AMP	66	Active	Fixed Us 0-10 Vdc
11166752 <sup>2</sup>	PVES-SP	1x6 DEU	67	Passive	Standard

<sup>1</sup> Includes *Disable Mode* special feature

<sup>2</sup> Includes *Spool Position* special feature

#### *PVG 120 variants*

<b>Part number</b>	<b>Type</b>	<b>Connector</b>	<b>IP</b>	<b>Fault monitoring</b>	<b>Functionality</b>
11166761	PVES	1x4 DEU	67	Passive	Standard
11166762	PVES	1x4 DIN	65	Passive	Standard

## Connector Overview

### Connector Overview

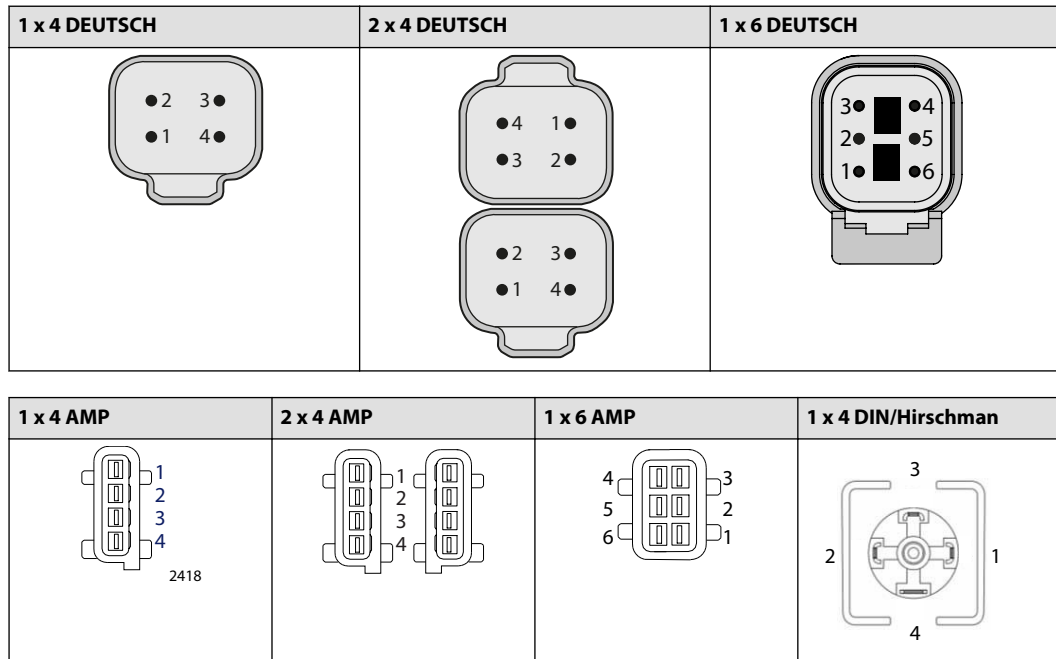

#### PVEO-DI 4-pin AMP Connector

Pinout	Pin 1	Pin 2	Pin 3	Pin 4
2x4 AMP (A)	$U_{DC\_A}$	$U_{DC\_B}$	GND	GND
2x4 AMP (B)	DI-B	DI-A	GND	$U_{DC2}$

#### PVEM 4-pin DIN Connector

Pinout	Pin 1	Pin 2	Pin 3	Pin 4
1x4 DIN	$U_{DC}$	$U_S$	Error	GND

#### PVEO, PVEO-R and PVEO-HP 4-pin Connector

Pinout	Pin 1	Pin 2	Pin 3	Pin 4
1x4 AMP	$U_{DC\_A}$	$U_{DC\_B}$	GND	GND
1x4 DEUTSCH	$U_{DC\_A}$	GND	GND	$U_{DC\_B}$
1x4 DIN	$U_{DC\_A}$	$U_{DC\_B}$	-	GND

#### PVEA/PVEH/PVES

Pinout	Pin 1	Pin 2	Pin 3	Pin 4
1x4 AMP	$U_S$	$U_{DC}$	GND	Error
1x4 DEUTSCH	$U_S$	Error	GND	$U_{DC}$
1x4 DIN	$U_{DC}$	$U_S$	Error	GND

#### PVEA-DI and PVEH-DI 4-pin Connector

Pinout	Pin 1	Pin 2	Pin 3	Pin 4
2x4 AMP (A)	$U_S$	$U_{DC}$	GND	Error
2x4 AMP (B)	DI-A	DI-B	GND	$U_{DC2}$



## Connector Overview

### *PVEA-DI and PVEH-DI 4-pin Connector (continued)*

Pinout	Pin 1	Pin 2	Pin 3	Pin 4
2x4 DEUTSCH (A)	U <sub>S</sub>	Error	GND	U <sub>DC</sub>
2x4 DEUTSCH (B)	U <sub>DC2</sub>	GND	DI-A	DI-B

### *PVEH-FLA 6-pin Connector*

Pinout	Pin 1	Pin 2	Pin 3	Pin 4	Pin 5	Pin 6
1x6 AMP	U <sub>S</sub>	U <sub>DC</sub>	GND	Error	Float	-

### *PVEH-SP and PVES-SP 6-pin Connector*

Pinout	Pin 1	Pin 2	Pin 3	Pin 4	Pin 5	Pin 6
1x6 DEUTSCH	U <sub>S</sub>	Error	-	SP	GND	U <sub>DC</sub>

## Fault Monitoring and Reaction

All proportional control PVE Series 7 actuators feature:

- Integrated fault monitoring
- Detecting spool stroke inconsistencies
- Detecting internal hardware defects
- Detecting demand signal inconsistencies
- Fault reaction depending on the type of fault monitoring
  - Generic
  - Specific

Passive and active fault monitoring refers to whether or not the actuator is reacting on the error when it is detected.

### Active fault monitoring

No matter what kind of error is detected, the solenoid valves will be disabled and the operation that the valves/spool controls will stop immediately and spool will go to neutral position. Active fault monitoring keeps a “memory” of the error, even if it is no longer registered. The active fault monitoring does not have Auto Recovery because of this “memory” and a reboot/restart will therefore be required to reactivate the solenoid valves.

With an active fault monitoring the following scenarios will take place when an error is detected/occurs:

- The LED light will switch from green to red and the error pin output will go high
- The solenoid valves will be disabled and the operation that the valves/spool controls will stop immediately
- The active fault monitoring does not have Auto Recovery, so when the error is fixed/no longer is registered a reboot/restart of the PVE is required to reactivate it.

### Passive fault monitoring

Passive fault monitoring does not disable the solenoid valves when an error is detected. It will continue to operate despite that an error was detected. When the error no longer is registered the passive fault monitoring will “forget” the error and continue as if the error was never there.

With a passive fault monitoring the following conditions will happen when an error is detected/occurs:

- The LED light will switch from green to red and the error pin output will go high
- The solenoid valves will continue operating at the set point given at the time of the error
  - Only exception is if the error is caused by the supply voltage ( $U_{DC}$ ) being either above or below the allowed range or if the temperature measured on the internal electronics board is higher than allowed. In these cases, the solenoid valves will be disabled.

## Generic Fault Reaction

All PVE actuators with fault monitoring are triggered by the following main events:

<b>Control Signal Monitoring</b>	The Control signal voltage ( $U_S$ ) is continuously monitored. The permissible range is between 15% and 85% of the supply voltage ( $U_{DC}$ ). Outside this range the PVE will switch into an error state. A disconnected $U_S$ pin (floating) is recognized as a neutral set point.
<b>Transducer/LVDT Supervision</b>	The internal LVDT wires are monitored. If the signals are interrupted or short-circuited, the PVE will switch into an error state.
<b>Supervision of Spool Position</b>	The actual position must always correspond to the demanded position ( $U_S$ ). If the actual spool position is further out from neutral than the demanded spool position or in opposite direction, the PVE will switch into an error state. Spool position closer to neutral and in same direction will not cause an error state – the situation is considered <i>in control</i> .

## Fault Monitoring and Reaction

<b>Float Position Monitoring</b>	Float position must be entered or left within a time limit. A too high delay on the 1x6 pin float PVE will cause an error state – this is relevant for the 1x6 pin PVEH-F actuators only.
<b>Temperature Monitoring</b>	When the temperature is too high the PVE LED will light constant red and solenoid valves will be disabled.

## Fault Reaction Overview

All entries have an Auto Recovery feature unless marked otherwise.

Description	Monitoring	LED	Solenoid valves	Error pin output	Fault reaction time	
					PVEM/H/S	PVEA
Spool not at setpoint	Active*		Disabled	High	500	750
	Passive		-	High	250	750
Unable to reach float position	Active*		Disabled	High	1000	1000
	Passive		-	High	1000	1000
U dc > max.	Active		Disabled	-	-	-
	Passive		Disabled	-	-	-
U dc < min.	Active		Disabled	-	-	-
	Passive		Disabled	-	-	-
Us out of range	Active*		Disabled	High	500	750
	Passive		-	High	250	750
LVDT error	Active*		Disabled	High	500	750
	Passive		-	High	250	750
Temp > max.	Active*		Disabled	High	250	750
	Passive		Disabled	High	250	750

\* Does not have Auto Recovery

## Error Pin Specification

All proportional control PVE Series 7 actuators feature an error pin, indicating when an error is detected/occurs, according to the Fault Reaction Overview table. The specifications of the error pin is shown below.

Description	No error	Error
Output state	Low	High
Output voltage	<2 Vdc	~Udc
Output current	Max. 100 mA	

## Functionality Overview

### Standard and Fixed US 0-10 Vdc

All standard proportional actuator variants (PVEM/PVEA/PVEH/PVES) can be controlled by an analog signal voltage ( $U_s$ ) or a PWM controlled signal voltage ( $U_s$ ) proportional to the supply voltage ( $U_{dc}$ ).

#### PVEO

Description	Type	Value	
Supply voltage ( $U_{dc}$ )	Rated	12 Vdc	24 Vdc
	Range	11 to 15 Vdc	22 to 30 Vdc
	Max. ripple	5%	

#### PVEM/PVEA/PVEH/PVES

Description	Type	Value
Supply voltage ( $U_{dc}$ )	Rated	11 to 32 Vdc
	Range	11 to 32 Vdc
	Max. ripple	5%
Signal voltage ( $U_s$ )	Neutral	$U_s = 0.5 \cdot U_{dc}$
	Q: P to A	$U_s = (0.5 \text{ to } 0.25) \cdot U_{dc}$
	Q: P to B	$U_s = (0.5 \text{ to } 0.75) \cdot U_{dc}$

The PVEH-U and PVES-U variants are controlled by a fixed 0-10 Vdc signal voltage ( $U_s$ ), directly compatible with standard PLC control.

#### PVEH-U

Description	Type	Value
Supply voltage ( $U_{dc}$ )	Rated	11 to 32 Vdc
	Range	11 to 32 Vdc
	Max. ripple	5%
Signal voltage ( $U_s$ )	Neutral	$U_s = 5 \text{ V}$
	Q: P to A	5 V to 2.5 V
	Q: P to B	5 V to 7.5 V

### Functionality Overview

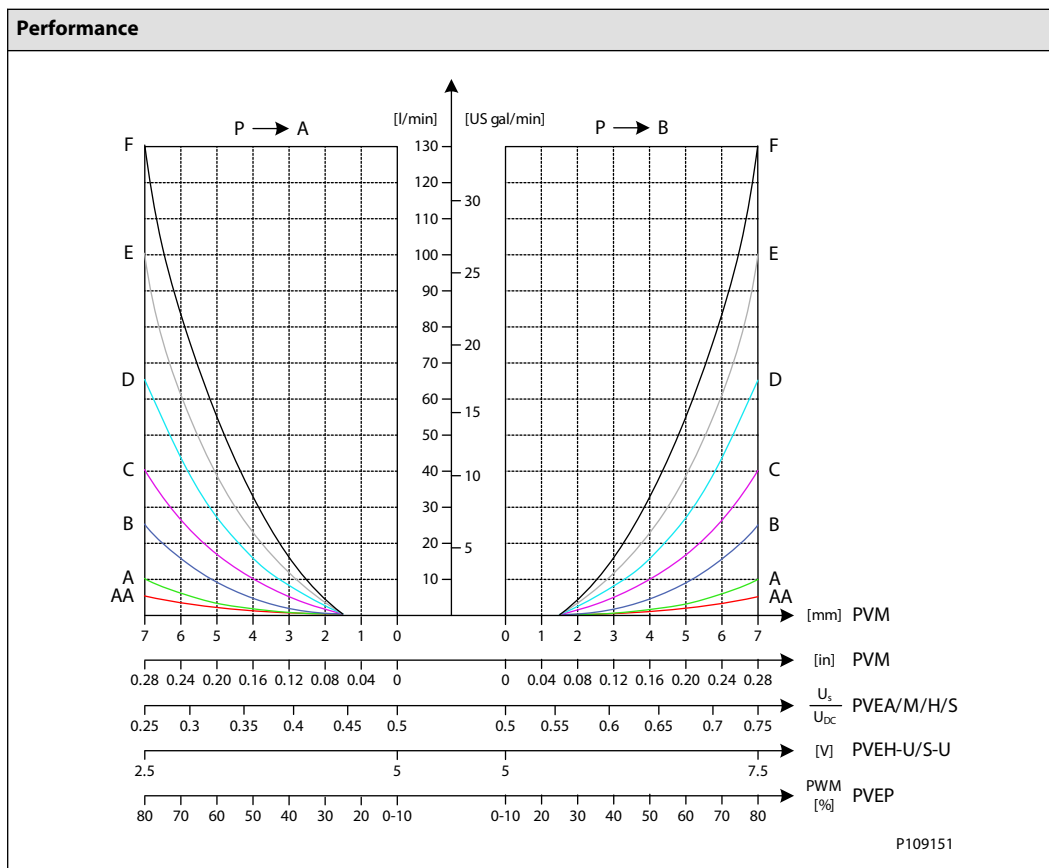

### PWM Voltage Control

The PVEM/PVEA/PVEH/PVES actuator variants can be controlled by a PWM controlled signal voltage ( $U_s$ ) proportional to the supply voltage ( $U_{dc}$ ).

The  $V_1$  and  $V_2$  must be symmetrical around  $U_{dc}/2$  and  $V_1$  must be equal to or less than  $U_{dc}$ .

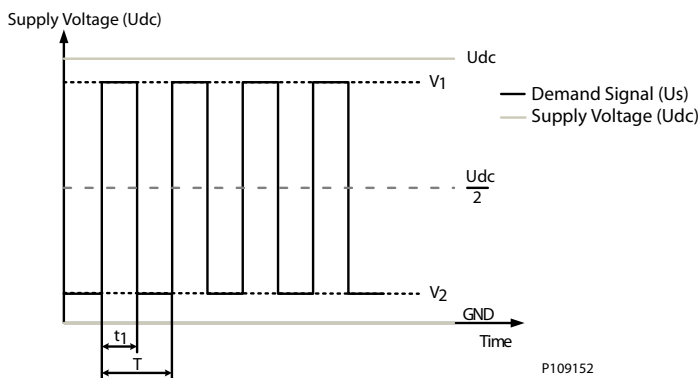

### PVEM Control Specification

Description	Type	Value
Supply Voltage ( $U_{dc}$ )	Rated	11 to 32 Vdc
	Range	11 to 32 Vdc
	Max. ripple	5%

## Functionality Overview

### *PVEM Control Specification (continued)*

Description	Type	Value
Signal Voltage PWM (Us)	Neutral	Us = 50% DUT
	Q: P to A	Us = 50% to 25% DUT
	Q: P to B	Us = 50% to 75% DUT
PWM Frequency (Us)	Recommended	> 200 Hz

### *PVEA/PVEH/PVES Control specification*

Description	Type	Value
Supply Voltage (Udc)	Rated	11 to 32 Vdc
	Range	11 to 32 Vdc
	Max. ripple	5%
Signal Voltage PWM (Us)	Neutral	Us = 50% DUT
	Q: P to A	Us = 50% to 25% DUT
	Q: P to B	Us = 50% to 75% DUT
PWM Frequency (Us)	Recommended	> 1000 Hz

## Functionality Overview

### Ramp (-R)

The Ramp functionality is a rate limitation of the spool stroke, resulting in extended reaction times and in some cases a smoother control of the main spool compared to the standard PVEO variant. The Ramp functionality of a *PVEO-R* variant is achieved purely hydraulically by implementing two orifices working on both sides of the main spool (integrated in the actuator). The Ramp functionality of a *PVEM-R* variant is achieved in the regulation principle.

*PVEO with ramp functionality (PVEO-R)*

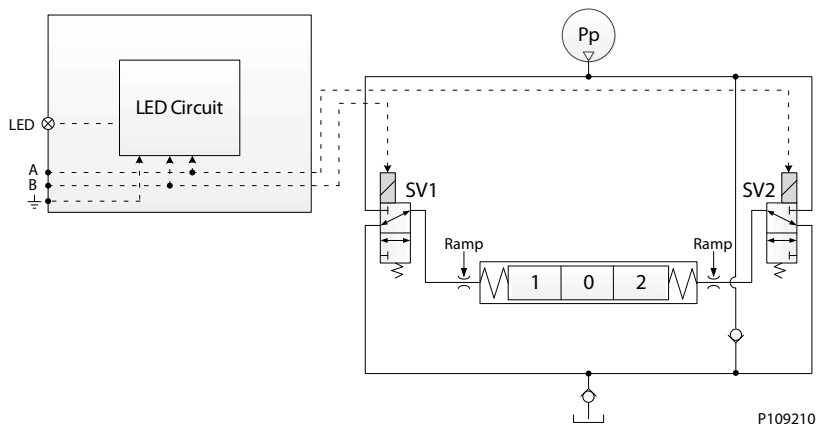

*PVEM with ramp functionality (PVEM-R)*

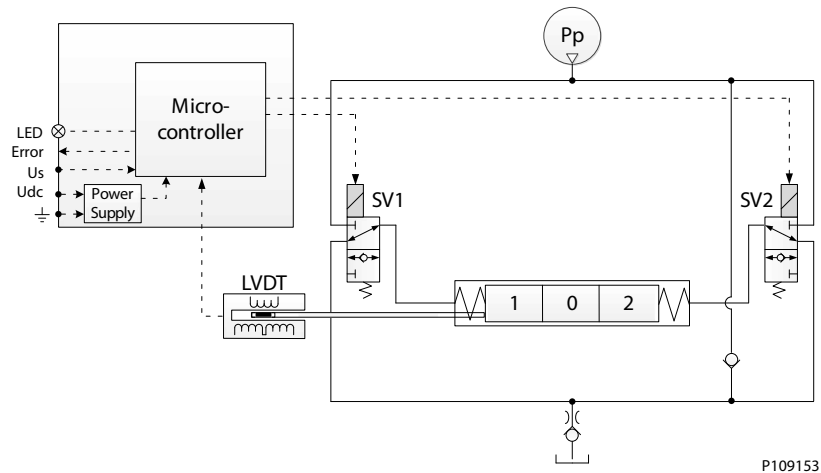

For reaction times, see [PVE S7 Reaction Times](#) on page 57

## Functionality Overview

### Quick Reaction (-Q)

The Quick Reaction functionality of the *PVEM-Q* variant results in shorter reaction times and a more rapid or aggressive control of the main spool compared to the standard PVEM variant. The Quick Reaction functionality of a PVEM-Q is achieved by replacing the combined orifice and check valve with a check valve in the connection to tank and changing the regulation principle.

*PVEM with quick reaction functionality (PVEM-Q)*

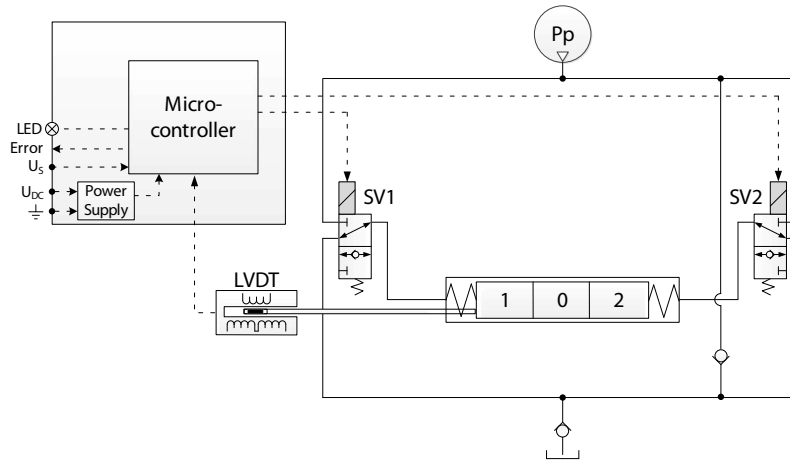

For reaction times, see [PVE S7 Reaction Times](#) on page 57.



## Functionality Overview

### Float B-Port (-FLB)

The Float B-Port functionality enables the proportional PVEM-FLB/PVEH-FLB actuator variants to enter the main spool into a float position. The PVE actuators with Float B-Port functionality is compatible with the dedicated main spools with electronic float in B-port.

PVE Type	PVBS Type	Standard FC	Float Control
PVEM-FLB (1x4 pin)	Deadband 1.5 mm Max. B-port flow 4.8 mm	$U_s = (0.35 \rightarrow 0.65) \cdot U_{DC}$	$U_s = 0.75 \cdot U_{DC}$
PVEH-FLB (1x4 pin)			

Float in B-port functionality

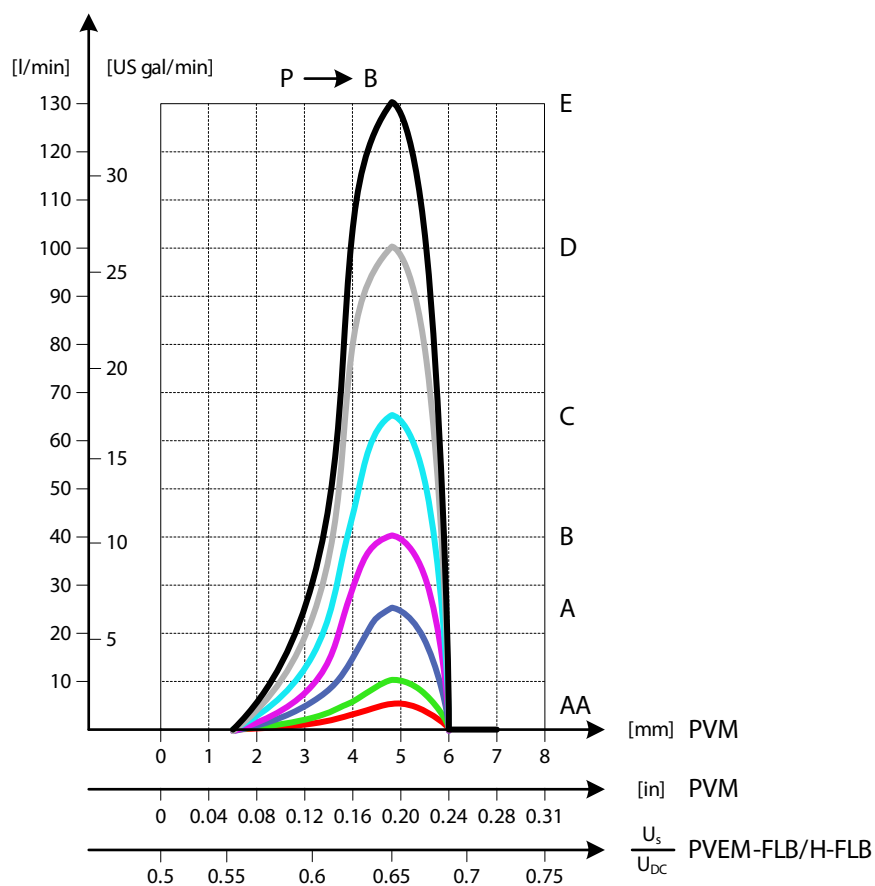

P109155

## Functionality Overview

### Float A-Port (-FLA)

The Float A-Port functionality enables the proportional PVEH-FLA actuator variants to enter the main spool into a float position. The PVE actuators with Float A-Port functionality is compatible with the dedicated main spools with electronic float in A-port.

PVE Type	PVBS Type	Standard Flow Control	Float Control
PVEH-FLA (1x6 pin)	Deadband 1.7 mm	$U_s = (0.25 \rightarrow 0.75) \cdot U_{dc}$	U <sub>dc</sub> to dedicated float pin (UF)
	Max. B-port flow 8.0 mm		

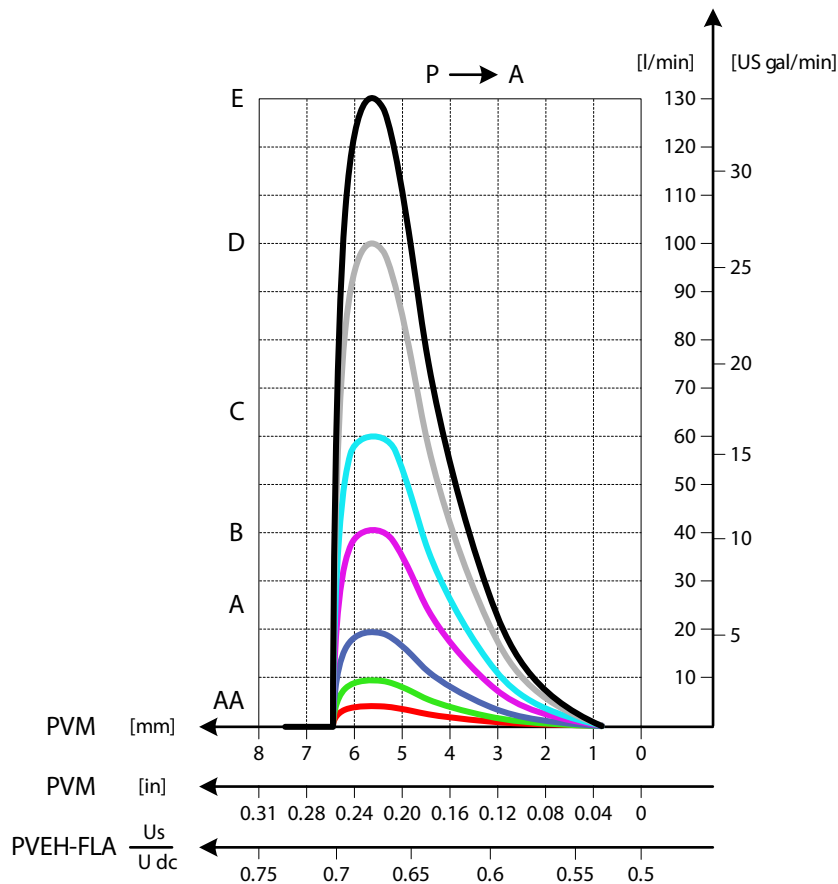

P109154

### PVE Power Save

All proportional actuator variants feature a Power Save mode, de-energizing the solenoid valve bridge. The Power Save mode is entered when the signal voltage ( $U_s$ ) and the LVDT spool position has been in neutral for 750 ms. As soon as the signal voltage ( $U_s$ ) or the LVDT spool position is out of neutral the PVE will leave its Power Save mode and re-energize the solenoid valve bridge as usual.

The Power Save mode results in increased power efficiency by reducing the current consumption of the PVE actuators in neutral position. The Power Save mode has no effect on the performance of the PVE actuator.

For current consumption values, please see chapter [Current Consumption](#).

## Special Features

### Direction Indication (-DI)

The PVEO-DI/PVEA-DI/PVEH-DI actuator variants feature an integrated Direction Indication output derived from the LVDT spool position, indicating the state of the main spool (neutral, A-port or B-port).

#### PVEO-DI functionality

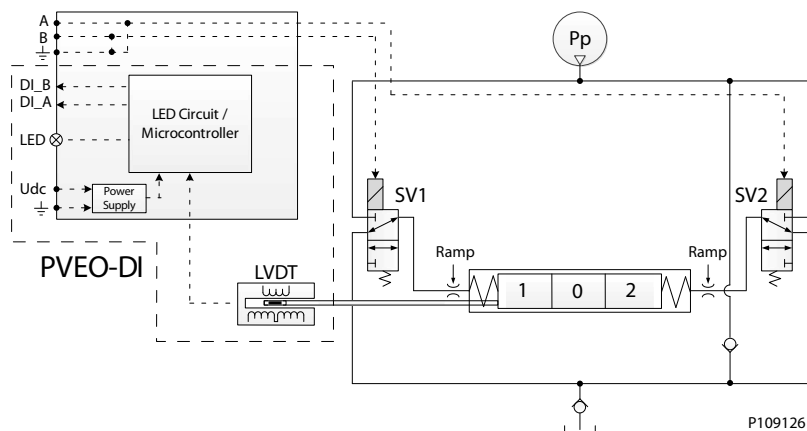

#### PVEA-DI functionality

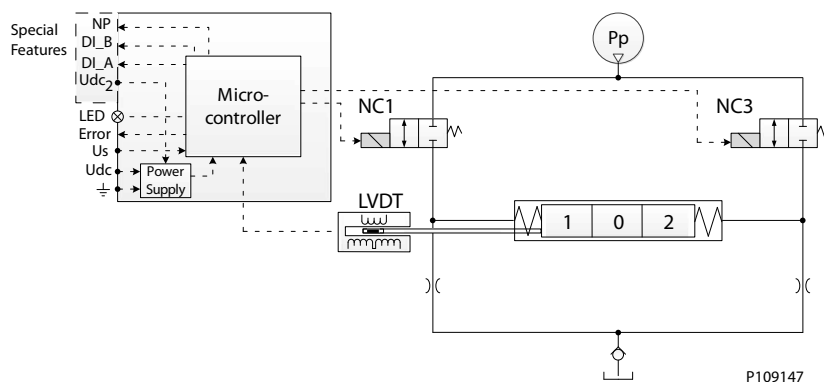

#### PVEH functionality

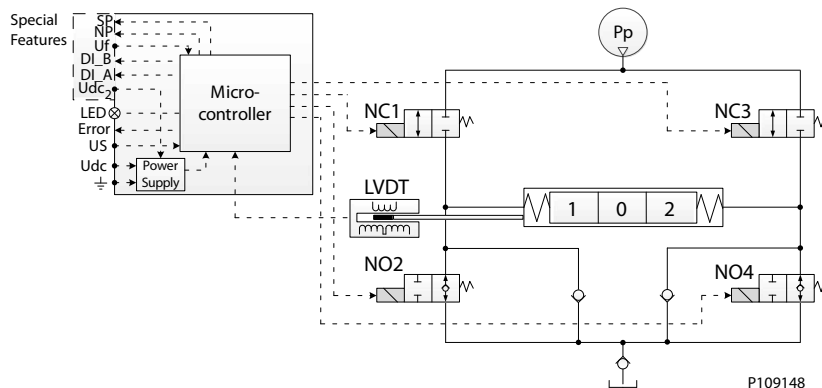

The Direction Indication feature uses a dual power supply with the 2x4 pin AMP and DEUTSCH connectors as shown in the chapter [Connector Overview](#) on page 40.

### Special Features

When both DI\_A and DI\_B signals are High the main spool is in its neutral position.

When the DI\_A signal goes Low and the DI\_B signal stays High, the main spool is moving in the A-port direction, and vice versa. The relation between the direction indication feedback and the output signal is shown below.

#### Direction indication feedback

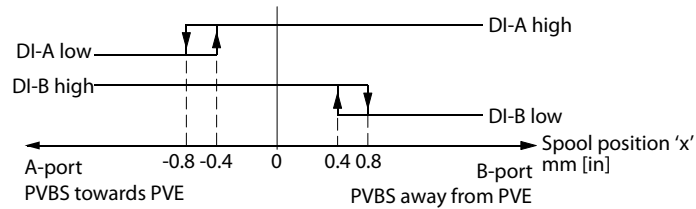

157-435.10

	A-Port	B-Port
DI signals a1, a2	-0.8 mm ± 0.4 mm	0.8 mm ± 0.4 mm
Max. DI load	200 mA	
DI High @ 20 mA	> U <sub>DC</sub> - 1.5 V <sub>DC</sub>	
DI High @ 100 mA	> U <sub>DC</sub> - 2.0 V <sub>DC</sub>	
DI Low	< 0.2 V <sub>DC</sub>	

## Special Features

### Dedicated Float Pin (UF)

The Dedicated Float Pin (UF) feature is related to the PVEH-FLA actuator variant enabling the user to move the main spool into its float position by power. The PVEH-FLA uses 1x6 pin AMP or DEUTSCH connectors.

- Normal operation: Low or not connected
- High Float
- Input range:  $U_{DC}$
- Max. voltage: 32  $V_{DC}$

*PVEH-FLA functionality diagram*

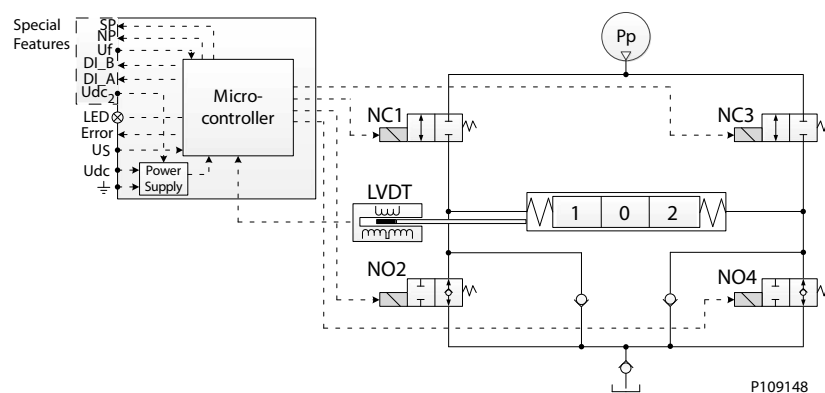

P109148

## Special Features

### Spool Position (SP)

The Spool Position (SP) feature available in the PVEH-SP/PVES-SP actuator variants enables the user to derive from the LVDT spool position of the main spool by means of an analog voltage signal on the dedicated spool position (SP) output pin.

*PVEH-SP functionality diagram*

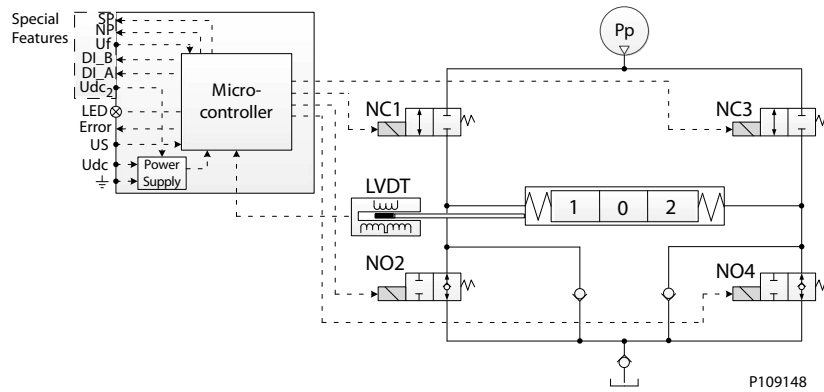

*PVES-SP functionality diagram*

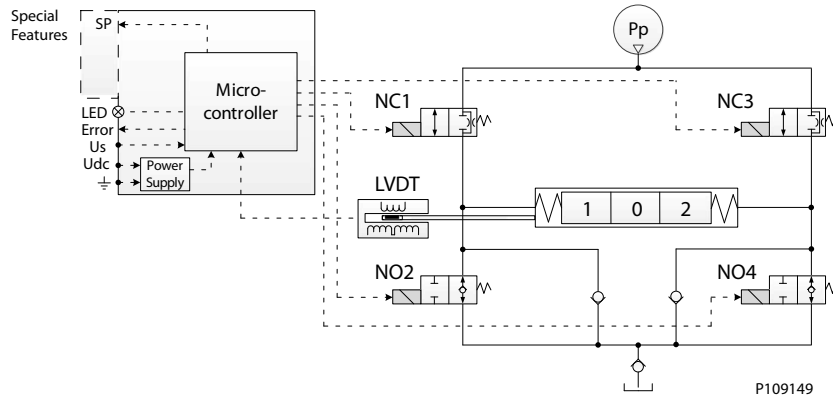

### Spool Position feedback

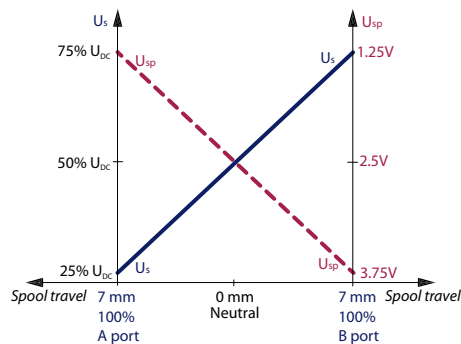

SP feedback signal from 0.5 to 4.0  $V_{DC}$  inverted in direction relative to  $U_s$  2.5  $V_{DC}$  as the neutral value  
 SP from neutral to maximum stroke (mm)  
 SP maximum load is 0.5 mA  
 Output range for A-port: 2.5 – 1.25  $V_{DC}$  and for B-port: 2.5 – 3.75  $V_{DC}$

The PVEH-SP/PVES-SP uses a 1x6 DEUTSCH connector. For more information, please see [Connector Overview](#) on page 40.

## Special Features

### Neutral Power-OFF (NP)

The Neutral Power-OFF (NP) feature available in the PVEA-NP and PVEH-NP actuator variants enables the user to identify whether the solenoid valves in the actuator are energized or de-energized via a dedicated neutral power-OFF (NP) output pin.

*PVEA-NP functionality diagram*

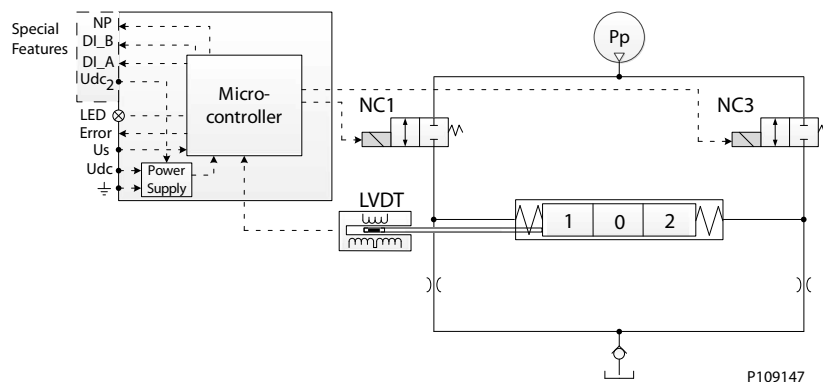

*PVEH-NP functionality diagram*

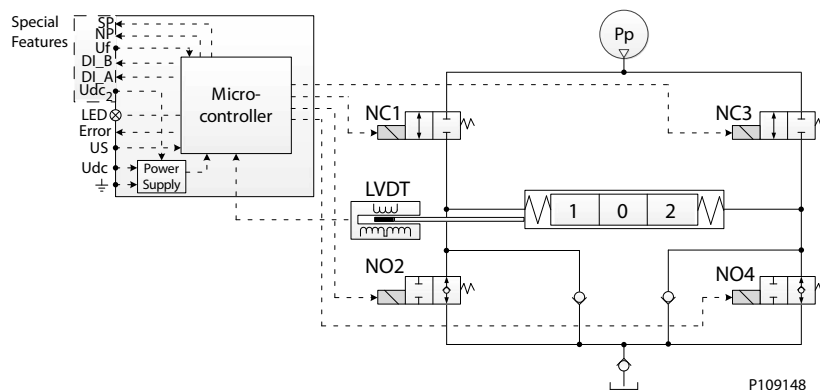

The Neutral Power-OFF (NP) signal is defined as shown below:

*Solenoid disabling function (-NP) curves*

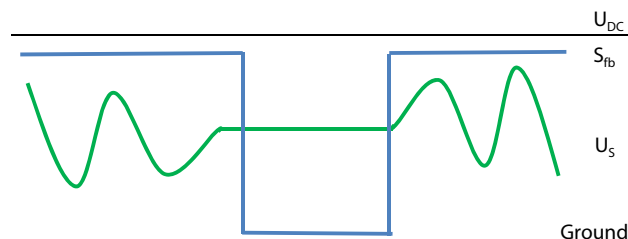

Normal operation from  $> U_{DC}$  to  $2 V_{DC}$

Power Save  $< 1 V_{DC}$  (solenoid valves de-energized)

NP maximum load is 50 mA

The PVEA-NP/PVEH-NP uses a 1x6 DEUTSCH connector. For more information, please see [Connector Overview](#) on page 40.

**Special Features****Disable Mode**

The PVEH-U and PVES-U actuator variants controlled by a fixed 0-10 V<sub>DC</sub> signal voltage (U<sub>S</sub>), feature the ability to enter a disable mode. This causes the counteracting force on the main spool created by the solenoid valve bridge to deactivate, when using Manual OverRide (MOR).

The disable mode is entered by sending a signal voltage (U<sub>S</sub>) of 16.2% of 10 V<sub>DC</sub> when in Power Save.



## Performance Overview

### PVE S7 Reaction Times

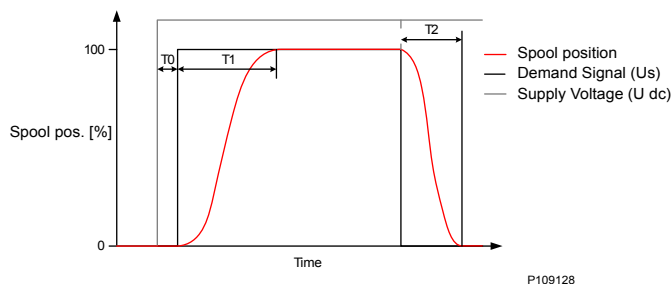

Reaction
T0 – Boot-up [ms]
T1 – Neutral to max. spool stroke
T2 – Max. spool stroke to neutral
T1 – Neutral to max. spool stroke
T2 – Max. spool stroke to neutral

#### PVG 32/100 PVEO—PVEM-R reaction times

Reaction	PVEO	PVEO-R	PVEO-HP	PVEM	PVEM-R
T0 [ms]	0	0	0	15	15
T1 @ Power ON [ms]	110	300	90	225	325
T2 @ Power OFF [ms]	110	110	70	110	110
T1 @ Constant U dc [ms]	110	300	90	210	310
T2 @ Constant U dc [ms]	110	110	70	90	90

#### PVG 32/100 PVEM-Q—PVES reaction times

Reaction	PVEM-Q	PVEA	PVEH	PVES
T0 [ms]	15	15	15	15
T1 @ Power ON [ms]	125	280	125	125
T2 @ Power OFF [ms]	110	200	110	110
T1 @ Constant U dc [ms]	110	265	110	110
T2 @ Constant U dc [ms]	90	200	90	90

## Hysteresis and Ripple

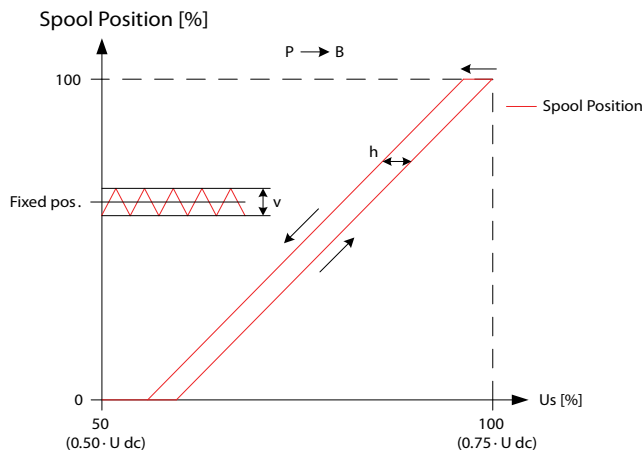

### Performance Overview

Type	Hysteresis (h)	Steady state ripple @ fixed Us (v)
	Rated [%]	Rated [mm]
<i>PVEM</i>	15	0.0
<i>PVEM-R</i>	15	0.0
<i>PVEM-Q</i>	15	0.0
<i>PVEA</i>	2	0.3
<i>PVEH</i>	4	0.0
<i>PVEH 256</i>	1.5	0.0
<i>PVES</i>	0	0.2

### Current Consumption

Type	Typical	Minimum	Maximum
	[mA]		
<i>PVEO @ 12 Vdc</i>	480	430	950
<i>PVEO @ 24 Vdc</i>	250	220	480
<i>PVEO-HP @ 12 Vdc</i>	750	660	1460
<i>PVEO-HP @ 24 Vdc</i>	380	340	740

Type	@ 12 Vdc	@ 24 Vdc
	[mA]	
<i>PVEM</i>	690	350
<i>PVEA</i>	290	150
<i>PVEH</i>	540	270
<i>PVES</i>	560	280

### Oil Consumption

Type	Neutral	Locked position	Actuating
	[l/min]		
<i>PVEO</i>	0.0	0.0	0.9
<i>PVEO-R</i>	0.0	0.0	0.3
<i>PVEO-HP</i>	0.0	0.0	0.9
<i>PVEM</i>	0.0	0.0	0.5
<i>PVEM-R</i>	0.0	0.0	0.3
<i>PVEM-Q</i>	0.0	0.0	0.3
<i>PVEA</i>	0.0	0.4	1.0
<i>PVEH</i>	0.0	0.0	0.7
<i>PVES</i>	0.3	0.1	0.8

**Dimension Overview**

**Dimension Overview for PVE Series 7**

*PVG 32/100 variants*

PVEO/PVEM/PVEA		PVEH/PVES		Connector Height
				DEU = 30 mm [1.2 in]
				AMP = 38 mm [1.5 in]
				DIN = 40 mm [1.6 in]

*PVG 120 variants*

PVEO		PVEH/PVES		Connector Height
				DEU = 30 mm [1.2 in]
				AMP = 38 mm [1.5 in]
				DIN = 40 mm [1.6 in]

**Dimension Overview**

PVG 128/256 variants

PVEO		PVEH		Connector Height
				DEU = 30 mm [1.2 in]
				AMP = 38 mm [1.5 in]
				DIN = 40 mm [1.6 in]

### Products we offer:

- DCV directional control valves
- Electric converters
- Electric machines
- Electric motors
- Gear motors
- Gear pumps
- Hydrostatic motors
- Hydrostatic pumps
- Orbital motors
- PLUS+1® controllers
- PLUS+1® displays
- PLUS+1® joysticks and pedals
- PLUS+1® operator interfaces
- PLUS+1® sensors
- PLUS+1® software
- PLUS+1® software services, support and training
- Position controls and sensors
- PVG proportional valves
- Steering components and systems
- Telematics

**Danfoss Power Solutions** is a global manufacturer and supplier of high-quality hydraulic and electric components. We specialize in providing state-of-the-art technology and solutions that excel in the harsh operating conditions of the mobile off-highway market as well as the marine sector. Building on our extensive applications expertise, we work closely with you to ensure exceptional performance for a broad range of applications. We help you and other customers around the world speed up system development, reduce costs and bring vehicles and vessels to market faster.

Danfoss Power Solutions – your strongest partner in mobile hydraulics and mobile electrification.

### Go to [www.danfoss.com](http://www.danfoss.com) for further product information.

We offer you expert worldwide support for ensuring the best possible solutions for outstanding performance. And with an extensive network of Global Service Partners, we also provide you with comprehensive global service for all of our components.

### Hydro-Gear

[www.hydro-gear.com](http://www.hydro-gear.com)

### Daikin-Sauer-Danfoss

[www.daikin-sauer-danfoss.com](http://www.daikin-sauer-danfoss.com)

Local address:

**Danfoss  
Power Solutions (US) Company**  
2800 East 13th Street  
Ames, IA 50010, USA  
Phone: +1 515 239 6000

**Danfoss  
Power Solutions GmbH & Co. OHG**  
Krokamp 35  
D-24539 Neumünster, Germany  
Phone: +49 4321 871 0

**Danfoss  
Power Solutions ApS**  
Nordborgvej 81  
DK-6430 Nordborg, Denmark  
Phone: +45 7488 2222

**Danfoss  
Power Solutions Trading  
(Shanghai) Co., Ltd.**  
Building #22, No. 1000 Jin Hai Rd  
Jin Qiao, Pudong New District  
Shanghai, China 201206  
Phone: +86 21 2080 6201

Danfoss can accept no responsibility for possible errors in catalogues, brochures and other printed material. Danfoss reserves the right to alter its products without notice. This also applies to products already on order provided that such alterations can be made without subsequent changes being necessary in specifications already agreed. All trademarks in this material are property of the respective companies. Danfoss and the Danfoss logotype are trademarks of Danfoss A/S. All rights reserved.