

Technical Information

Proportional Valves

PVED-CC, Series 5 ISObus

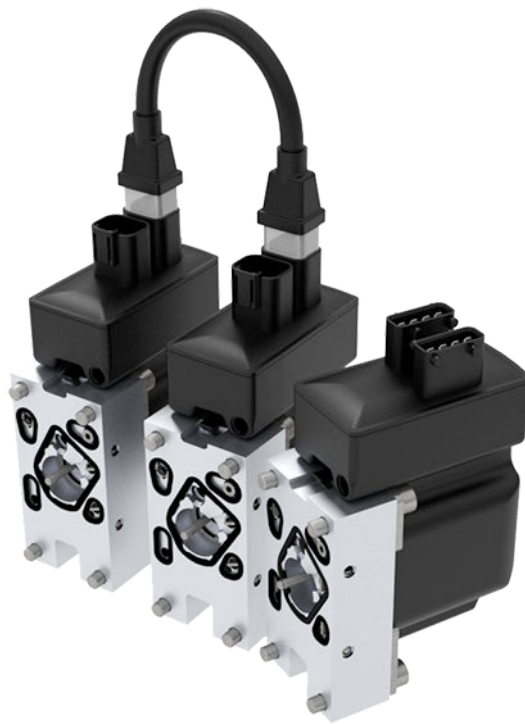

Revision history

Table of revisions

Date	Changed	Rev
November 2019	Added 4m EMC proof cables to ISOBus code numbers	0105
October 2017	Correction - AMP connector	0104
July 2017	Correction to image 'AMP 2x 4pin AMT Junior Power Timer.'	0103
February 2016	Literature order number changed.	0102
February 2016	Parameter overview table, Temperature dependent spool timeout float addon parameter: Range and default updated	0101
October 2015	ISOBus added to the title	0001
June 2015	First version	0000

Contents

Introduction

PVED-CC ISOBus code numbers.....	4
----------------------------------	---

Technical data

Operating data overview.....	5
Connectors.....	6
LED coloring for PVED-CC Series 5.....	7
Physical dimensions.....	7
PVED-CC Hysteresis and Ripple.....	8
PVED-CC Reaction Times.....	8

Communication

PVED-CC ISOBus message overview.....	9
PVED-CC Address claim.....	9
Commanded address.....	10
PGN: Auxiliary Valve Command.....	10
PGN: Auxiliary Valve Estimated Flow.....	11
PGN: Vehicle Fluid Temperature.....	12
PGN: Diagnostic Message 1.....	13
PGN: Diagnostic Message 2.....	15
PGN: Diagnostic Message 3.....	18
PGN: Diagnostic Message 4.....	18
PGN: Diagnostic Message 11.....	22
PGN: Diagnostic Message 13.....	23

Parameters

Parameter overview.....	24
PVED-CC ISOBus Process data.....	26
Process data messages.....	26
Process data overview.....	26
Setpoint transfer feature: Write process data.....	27
Frame format.....	27
Write data.....	27
Linked fault flags.....	27
Read data.....	28

Diagnostics

PVED-CC (ISOBus) Diagnostics log	29
Diagnostic history.....	31
Temperature histogram.....	31

PVED-CC ISOBus Introduction

The PVED-CC Series 5 ISOBUS is a high performance digital actuator for the valve families PVG 32 and PVG 100.

The PVED-CC Series 5 ISOBUS offers CAN bus control through loop cables simplifying the wire harness and build-in intelligence where actuator specific features tailor the actuator behavior to the exact function need.

PVED-CC ISOBus code numbers

Connector type	Code number	Description
DEUTSCH	11107869	PVED-CC
	11007498	4 m cable
	11095741	4 m EMC proof cable (twisted pair)
	11007531	0.1 m loop cable
	11111916	0.3 m loop cable
	11095622	0.175 loop cable
	11007561	CAN bus terminator
AMP	11107870	PVED-CC
	157B4994	4 m cable with gray connector
	157B4995	4 m cable with black connector
	11095740	4 m EMC proof cable (twisted pair)
	157B4987	0.1 m loop cable
	11095581	0.175 m loop cable
	11163647	CAN bus terminator with gray connector
	157B4988	CAN bus terminator with black connector

Technical data

Operating data overview

Electrical data

Voltage		12 V _{DC}	24 V _{DC}
Current consumption	Operating	520 mA	260 mA
	Neutral - Power state	80 mA	45 mA
Energy consumption	Operating	6.24 W	6.24 W
	Neutral - Power state	1 W	1.1 W
Supply voltage (V _{bat})	Nominal	11 – 32 V _{DC}	
	Range	9 – 35.9 V _{DC}	
	Maximum ripple	5%	
CAN bus	Alive	5.5 – 36 V _{DC} *	

* PVED communicating on CAN bus, but not fully operable.

Temperature range

		Min.	Max.
Temperature	Ambient	-40°C	90°C
	Oil		110°C
	Storage		

Hydraulic data

Pilot pressure		13.5 ± 1.5 bar
Tank pressure	Continues	25 bar
	Intermittent	40 bar
Oil consumption	Electrical de-energized	0 l/min
	Spool locked position	
	Continuous changing spool position	0.7 l/min
Contamination	(ISO 4406)	23/19/16
Viscosity range	Nominal	12 – 75 mm ² /s
	Minimum	4.2 – 12 mm ² /s*
	Maximum	75 – 1000 mm ² /s

* PVED have reduced operating performance

Government regulations

Description	Standard
Low Voltage	2006/95/EC
EMC Directive	2004/108/EC
Safety	ISO4413:2010

Technical data

Connectors

Available 2x4 pin connectors: AMP Junior Power Timer and DEUTSCH DT06-4S-E003. Pins are internally connected in pairs between connectors. Mating connectors are not supplied by Danfoss.

AMP connector

AMP Junior Power Timer (2x4 pin)

Pinout:
1. CAN Low
2. Vbat+
3. GND
4. CAN High

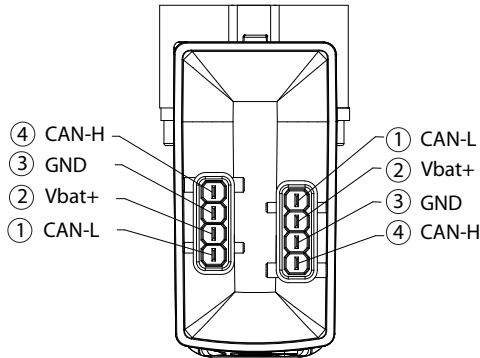

Terminal	Seal	Housing	IP rating
929930-1 (4 pcs)	828901-1 (4 pcs)	2-967059-1 (gray) or 1-967059-1 (black) *	IP66

* There is no black/gray coding of the connector

DEUTSCH connector

DT06-4S-E003 (2x4 pin)

Pinout:
1. CAN High
2. CAN Low
3. Vbat+
4. GND
IP rating: IP67; IP69K without connector

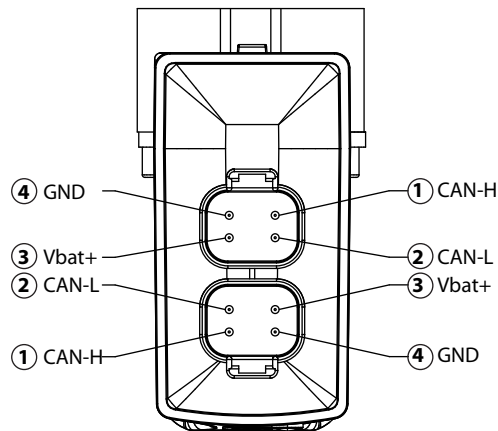





V310451.A

Technical data

LED coloring for PVED-CC Series 5

LED Characteristic

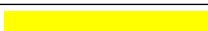
Color	LED Characteristic	Description
Green constant		No error – Actuating
Green flashing @ 1.5 Hz		Neutral – Power save
Red constant		Internal error
Red flashing @ 1.5 Hz		External or Float error
Yellow		Disable mode

Physical dimensions

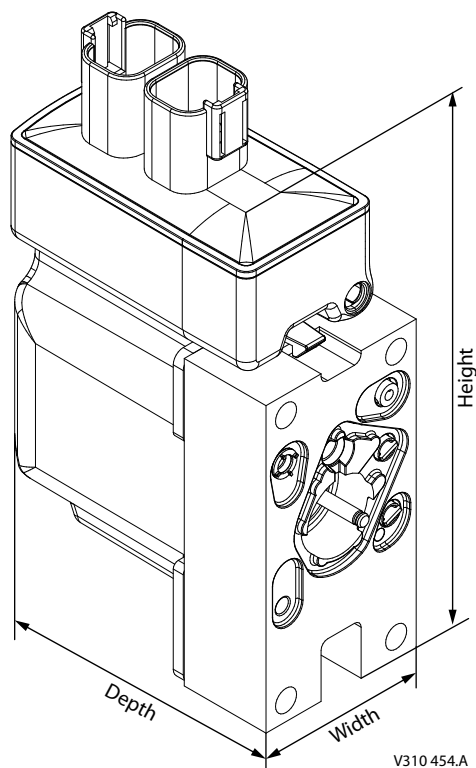

Depth		Width		Height*	
85 mm	[3.35 in]	45 mm	[1.77 in]	116 mm	[4.57 in]

* Excluding connector height

Technical data

PVED-CC Hysteresis and Ripple

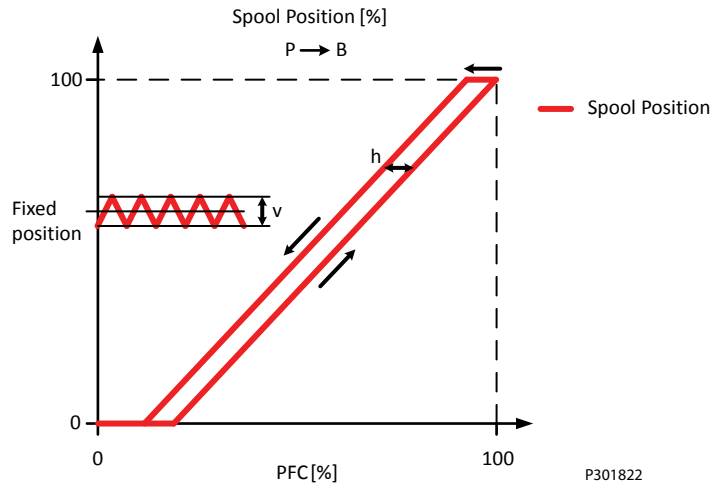

Definition of hysteresis

Hysteresis (h)	Rated [%]	1.45%
Steady state ripple at constant command signal	Rated [%]	0.29%

PVED-CC Reaction Times

Reaction times

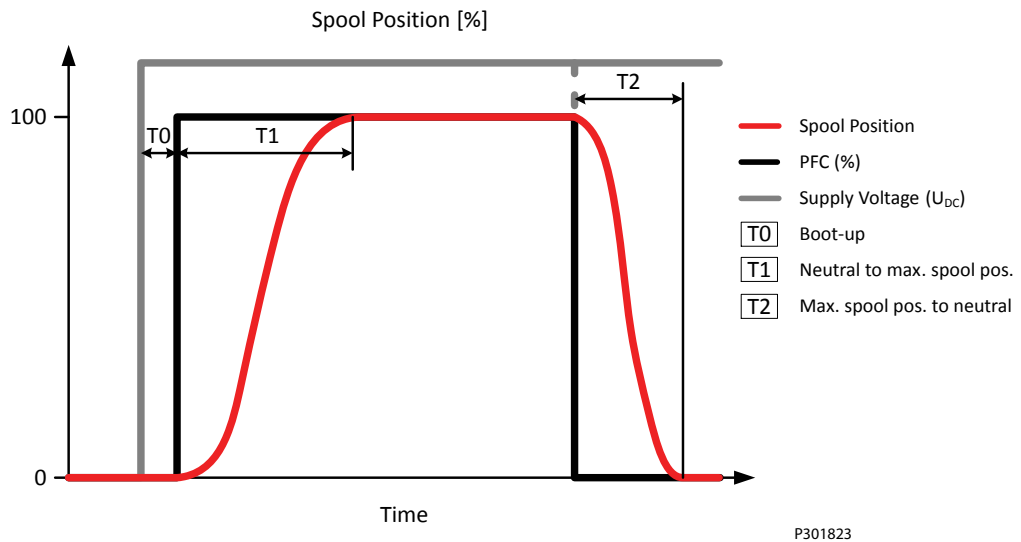

Definition of Step Response

Reaction	Time (nominal)
T0 – Boot-up	440 ms*
T1 – Constant PFC command	177 ms
T2 – Constant PFC command	114 ms

* Including Power-On-Self-Test (POST) and safety sub-system initialization.

Communication

PVED-CC ISOBus message overview

Message ID	Message type	DLC	Translation	Direction (from controller)	Timing
0x18EEFFyy*	PVED-CC Address claim on page 9	8	Claim address on CAN bus	Rx	On power-up
0x0CFE3xyy*	PGN: Auxiliary Valve Command on page 10	3 or 8	Auxiliary valve command	Tx	Controller dependent Recommended: 100 ms
0x0CFE1xyy*	PGN: Auxiliary Valve Estimated Flow on page 11	= AVC DLC	Auxiliary Valve Estimated Flow	Rx	Configurable Recommended: 100 ms
0x18FE68yy*	PGN: Vehicle Fluid Temperature on page 12	8	Vehicle fluid temperature	Tx	Controller dependent
0x18FECAYy*	PGN: Diagnostic Message 1 on page 13	8	Active Diagnostic Trouble Code	Rx	1000 ms/event triggered
0x18EAxxyy*	PGN: Diagnostic Message 2 on page 15	3	Previously Active Diagnostic Trouble Codes	Tx	On request
0x18FECByy*	DM2 data on page 16	8		Rx	On request
0x18EAxxyy*	PGN: Diagnostic Message 3 on page 18	3		Tx	On request
0x18EAFfyy*	DM 3 data on page 18	3	Freeze Frame Parameters	Rx	On request
0x18EAxxyy*	PGN: Diagnostic Message 4 on page 18	6		Tx	On request
0x1CEBxxyy*	DM4 on page 19	8	Reset of Active Diagnostic Trouble Codes	Rx	On request
0x18EAxxyy*	PGN: Diagnostic Message 11 on page 22	3		Tx	On request
0x18E8FFyy*	DM 11 data on page 23	8		Rx	On request
0x18DFFfyy*	PGN: Diagnostic Message 13 on page 23	8	Stop/Start broadcast	Tx	On request

*x = destination address (0x0-0xF), yy = source address

PVED-CC Address claim

Upon power-up the PVED will log onto the CAN bus network by claiming the address it has been given upon parameterization.

Frame format

Msg ID	DLC	Byte 1	Byte 2	Byte 3	Byte 4	Byte 5	Byte 6	Byte 7	Byte 8
0x18EEFFyy*	8	Name							

*yy = source address

Address claim data

Byte 1	0x01	Identity number							
Byte 2	0x00	Name assigned by Danfoss 0x001							
Byte 3	0x20 0x07	Bits 16 to 13:				Identity number			
		Bits 12 to 1:				Manufacturer Code			
Byte 4		Danfoss = 0x39							
Byte 5	0x08	Bit 8 to 4:				Function Instance (0x00)			
		Bits 3 to 1:				ECU Instance (0x0x1)			

Communication

Byte 6	0xFF	Function (0xFF)	
Byte 7	0x02	Bits 8 to 2:	Vehicle System (0x01)
		Bit 1:	Reserved (0x01)
Byte 8	0x20	Bit 8:	Arbitrary address (0x00)
		Bits 7 to 5:	Industry Group – Agriculture and Forestry (0x02)
		Bits 4 to 1:	Vehicle system instance (0x00)

Commanded address

Commanded address enables the master to rename the PVED.

Only one PVED with same address can be present at the network at a time.

Frame format

	Message ID	DLC	Byte 1	Byte 2	Byte 3	Byte 4	Byte 5	Byte 6	Byte 7	Byte 8
BAM	0x1CECFyy*	8	BAM	No of bytes	No of packets	Reserved	PGN			
DT 1	0x1CEBFyy*	8	Sequence	Name						
DT 2	0x1CEBFyy*	8	Sequence	Name cont.	New node ID	Reserved				

* yy = source address

Upon receiving new node ID the PVED will perform a reset of itself. After reset it will claim the new address.

PGN: Auxiliary Valve Command

The Auxiliary Valve Command (abbreviated AVC) is the command value sent from a master controller to control the PVED. The PVE will only accept messages with correct node ID and ignore any AVC commands if invalid.

Frame format

Msg ID	DLC	Byte 1	Byte 2	Byte 3	Byte 4	Byte 5	Byte 6	Byte 7	Byte 8
0x0CFE3xyy*	3 or 8**	PFC	Reserved	Valve state	Reserved				

* x = destination address (0x0-0xF), yy = source address

** Both DLC of 3 or 8 is valid for AVC message. Any other DLC will cause the PVED to raise an error flag.

Transmission rate: 100ms (recommended)

Transmission rate range: Recommended minimum Tx = 10ms

Recommended maximum Tx = AVC Timeout/2

AVC data

Byte 1*	Port Flow Command	Request port flow as a percentage of full flow Resolution:	0.4%/bit
		Valid range:	0-100%
			0 - 250
			0x00 – 0xFA

Communication

Byte 2	Reserved (FF)		
Byte 3**	Valve state	Bits 8 and 7:	Fail safe mode – block (0x00) supported
		Bits 6 and 5:	Reserved
		Bits 4 to 1:	Valve state:
			Blocked (neutral) = 0b0000
			Extend = 0b0001
			Retract = 0b0010
			Float = 0b0011
Hand operation = 0b1010			
Emergency stop = 0b1110			
Byte 4	Reserved (FF)		
Byte 5			
Byte 6			
Byte 7			
Byte 8			

* PFC = 0 is interpreted as a neutral command

** In blocked state the value in PFC is ignored

Linked fault flags

Fault	SPN	FMI
AVC not received within timeout period	298985	19
Invalid data in AVC	520676	19

PGN: Auxiliary Valve Estimated Flow

The Auxiliary Valve Estimated Flow (abbreviated AVEF) is the feedback sent from the PVED to the master controller telling the assumed flow/spool position.

Frame format

Msg ID	DLC	Byte 1	Byte 2	Byte 3	Byte 4	Byte 5	Byte 6	Byte 7	Byte 8
0x0 CFE1xyy*	3 or 8**	Extend port flow	Retract port flow	Valve state	Reserved				

* x = destination address (0x0-0xF), yy = source address

** The DLC will follow that of the AVC PGN.

Default transmission rate:

100ms (recommended)

Transmission rate range:

Minimum Tx = 10ms

Maximum Tx = 10 000ms

Communication

AVEF data

Byte 1	Extend port flow		
	Estimated flow out of extend port as a percentage of full flow		
	Resolution:	1%/bit	
		Offset:	125
			0x7D
	Date range:	0-100%	
125 - 255			
0x7D – 0xE1			
Byte 2	Retract port flow		
	Estimated flow out of retract port as a percentage of full flow		
	Resolution:	1%/bit	
		Offset:	125
			0x7D
	Date range:	0-100%	
125 - 255			
0x7D – 0xE1			
Byte 3	Valve state	Bits 8 and 7:	Fail safe mode – 0b00 and 0b01 is supported but safe state is always blocked
		Bits 6 and 5:	Reserved
		Bits 4 to 1:	Valve state:
		Block (neutral) = 0b0000	
		Extend = 0b0001	
		Retract = 0b0010	
	Float = 0b0011		
	Hand operation = 0b1010		
	Error = 0b1110		
Byte 4	Reserved (FF)		
Byte 5			
Byte 6			
Byte 7			
Byte 8			

PGN: Vehicle Fluid Temperature

The Vehicle Fluid Temperature can be used as input for the temperature dependent spool timeout. If the PGN VFT is not received by the actuator within 10000ms the onboard temperature sensor will be used as trigger.

Frame format

Msg ID	DLC	Byte 1	Byte 2	Byte 3	Byte 4	Byte 5	Byte 6	Byte 7	Byte 8
0x18FE68yy*	8	Temperature	Data not of importance						

*yy = source address

Communication

VFT data

Byte 1	Temperature in °Celsius	Resolution:	1 °C/bit
		Offset:	40 0x28
		Date range:	-40-120 °C
			0 - 160 0x00 – 0xA0
Byte 2	Reserved (FF)		
Byte 3			
Byte 4			
Byte 5			
Byte 6			
Byte 7			
Byte 8			

PGN: Diagnostic Message 1

The Active trouble code message (abbreviated DM1) is used by the PVED to transmit an active fault onto the CAN bus and give as a periodic status message.

Frame format

Msg ID	DLC	Byte 1	Byte 2	Byte 3	Byte 4	Byte 5	Byte 6	Byte 7	Byte 8
0x18CEFAyy*	8	Lamp status	Flash status	Fault information			Occurrence counter	Reserved	

* yy = source address

Default transmission rate: 1000ms (Can be disabled) / event triggered

DM1 data

Byte 1	Lamp status		
	Used by controller – not related to the actuator LED		
	No fault (default state):		0x00
	Warning and Info type faults:	Amber lamp:	0x04
	Critical or Severe type faults:	Red lamp:	0x10
Byte 2	Flash status		
	Used by controller – not related to the actuator LED	Flashing:	0xFF
Byte 3	Fault information	Bits 24 to 6:	SPN of active fault
Byte 4		Bits 5 to 1:	FMI of active fault
Byte 5			
Byte 6	Occurrence counter (OC)	Bit 8:	Conversion method
		Bits 7-1:	Occurrence counter
			Number of times the active fault has appeared previously
Byte 7	Reserved (FF)		
Byte 8			

Communication

In the event of multiple faults happening simultaneously the PVED will use the Broadcast Announce Message (BAM) transport protocol.

The BAM message size depends on the number of previous faults.

Frame format

Msg ID	DLC	Byte 1	Byte 2	Byte 3	Byte 4	Byte 5	Byte 6	Byte 7	Byte 8
0x1CECFy [*]	8	BAM	No of bytes		No of packets	Reserved	DM 1 PGN		
0x1CEBFy [*]	8	Sequence	Lamp status	Reserved	Fault 1			Fault 2	
0x1CEBFy [*]	8	Sequence	Fault 2 cont.		Fault 3				
0x1CEBFy [*]	8	Sequence	Fault 4			BAM cont.			

^{*}yy = source address

Transport protocol from J1939-21

BAM	Byte 1	BAM		
	Byte 2	Number of bytes		
	Byte 3			
	Byte 4	Number of packets		
		How many messages are sent in the complete BAM		
	Byte 5	Reserved (FF)		
	Byte 6	DM 1 PGN (0x00FECA)		
	Byte 7			
	Byte 8			
Data Transfer DT1	Byte 1	Sequence		
		Identification number of the BAM message in the BAM sequence		
	Byte 2	Lamp status		
		Used by controller – not related to the actuator LED		
		Info or warning type faults:	Amber lamp:	0x04
	Critical or severe type faults:	Red lamp:	0x10	
	Byte 3	Reserved (FF)		
	Byte 4	Fault information of fault 1	Bits 24 to 6:	SPN of fault
	Byte 5		Bits 5 to 1:	FMI of fault
	Byte 6			
	Byte 7	Occurrence counter		
		Number of times the active fault has appeared previously		
	Byte 8	Fault information of fault 2		
SPN of fault				

Communication

Data Transfer DT2	Byte 1	Sequence		
		Identification number of the BAM message in the BAM sequence		
	Byte 2	Fault information of fault 2 cont.	Bits 24 to 6:	SPN of fault
	Byte 3		Bits 5 to 1:	FMI of fault
	Byte 4	Occurrence counter		
		Number of times the active fault has appeared previously		
	Byte 5	Fault information of fault 3	Bits 24 to 6:	SPN of fault
	Byte 6		Bits 5 to 1:	FMI of fault
Byte 7				
Byte 8	Occurrence counter			
	Number of times the active fault has appeared previously			
Data Transfer DT3	Byte 1	Sequence		
		Identification number of the BAM message in the BAM sequence		
	Byte 2	Fault information of fault 3	Bits 24 to 6:	SPN of fault
	Byte 3		Bits 5 to 1:	FMI of fault
	Byte 4			
	Byte 5	Occurrence counter		
		Number of times the active fault has appeared previously		
	Byte 6	BAM continued		
Byte 7				
Byte 8				

PGN: Diagnostic Message 2

The Previously Active Diagnostic Trouble Codes (abbreviated DM2) is used to trigger the PVED to transmit all previously active fault onto the CAN bus.

Frame format

Request frame format

Msg ID	DLC	Byte 1	Byte 2	Byte 3
0x18EAxyy*	3	Request PGN LSB	Request PGN MSB	0x00
		0xCB	0xFE	

*xx = destination address (0x80-0x8F), yy = source address

Response frame format

Msg ID	DLC	Byte 1	Byte 2	Byte 3	Byte 4	Byte 5	Byte 6	Byte 7	Byte 8
0x18FECByy*	8	Lamp status	Flash status	Fault information			Occurrence counter	Reserved	

*yy = source address

Transmission rate:

on request

Communication

DM2 data

Byte 1	Lamp status		
	Used by controller – not related to the actuator LED		
	No fault (default state):		0x00
	Warning and Info type faults:	Amber lamp:	0x04
	Critical or Severe type faults:	Red lamp:	0x10
Byte 2	Flash status		
	Used by controller – not related to the actuator LED	Flashing:	0xFF
Byte 3	Fault information	Bits 24 to 6:	SPN of active fault
Byte 4		Bits 5 to 1:	FMI of active fault
Byte 5			
Byte 6	Occurrence counter (OC)		
	Number of times the active fault has appeared previously		
Byte 7	Reserved (FF)		
Byte 8			

In the event of Multiple previously active faults the PVED will use the Broadcast Announce Message (BAM) transport protocol.

The BAM message size depends on the number of previous faults.

Frame format

Msg ID	DLC	Byte 1	Byte 2	Byte 3	Byte 4	Byte 5	Byte 6	Byte 7	Byte 8
0x1CECFyy*	8	BAM	No of bytes		No of packets	Reserved	DM 2 PGN		
0x1CEBFyy*	8	Sequence	Lamp status	Reserved	Fault 1			Fault 2	
0x1CEBFyy*	8	Sequence	Fault 2 cont.			Fault 3			
0x1CEBFyy*	8	Sequence	Fault 4				BAM cont.		

*yy = source address

Transport protocol from J1939-21

BAM	Byte 1	BAM
	Byte 2	Number of bytes
	Byte 3	
	Byte 4	Number of packets
		How many messages are sent in the complete BAM
	Byte 5	Reserved (FF)
	Byte 6	DM 2 PGN (0x00FECB)
	Byte 7	
Byte 8		

Communication

Data Transfer DT1	Byte 1	Sequence		
		Identification number of the BAM message in the BAM sequence		
	Byte 2	Lamp status		
		Used by controller – not related to the actuator LED		
		Info or warning type faults:	Amber lamp:	0x04
		Critical or severe type faults:	Red lamp:	0x10
	Byte 3	Reserved (FF)		
	Byte 4	Fault information of fault 1	Bits 24 to 6:	SPN of fault
	Byte 5		Bits 5 to 1:	FMI of fault
	Byte 6			
Byte 7	Occurrence counter			
	Number of times the active fault has appeared previously			
Byte 8	Fault information of fault 2			
	SPN of fault			
Data Transfer DT2	Byte 1	Sequence		
		Identification number of the BAM message in the BAM sequence		
	Byte 2	Fault information of fault 2 cont.	Bits 24 to 6:	SPN of fault
	Byte 3		Bits 5 to 1:	FMI of fault
	Byte 4	Occurrence counter		
		Number of times the active fault has appeared previously		
	Byte 5	Fault information of fault 3	Bits 24 to 6:	SPN of fault
	Byte 6		Bits 5 to 1:	FMI of fault
	Byte 7			
	Byte 8	Occurrence counter		
Number of times the active fault has appeared previously				
Data Transfer DT3	Byte 1	Sequence		
		Identification number of the BAM message in the BAM sequence		
	Byte 2	Fault information of fault 3	Bits 24 to 6:	SPN of fault
	Byte 3		Bits 5 to 1:	FMI of fault
	Byte 4			
	Byte 5	Occurrence counter		
		Number of times the active fault has appeared previously		
	Byte 6	BAM continued		
	Byte 7			
	Byte 8			

Busy response

If the BAM session is unavailable due to ongoing transmission of DM1 or DM2 messages a busy response will be transmitted.

Msg ID	DLC	Byte 1	Byte 2	Byte 3	Byte 4	Byte 5	Byte 6	Byte 7	Byte 8
0x18E8FFyy*	8	Control byte	0x00	Reserved		Address busy acknowledge	Requested PGN		
		0x02		0xFF	0xFF				

*yy = source address

Communication

PGN: Diagnostic Message 3

The Clear/Reset of Previously Active Diagnostic Trouble Codes (abbreviated DM3) is used by the controller to clear the diagnostics log within the PVED

Frame format

Request frame format

Msg ID	DLC	Byte 1	Byte 2	Byte 3
0x18EAxxyy*	3	Request PGN LSB	Request PGN MSB	0x00
		0xCC	0xFE	

* xx = destination address (0x80-0x8F), yy = source address

Response frame format

Msg ID	DLC	Byte 1	Byte 2	Byte 3	Byte 4	Byte 5	Byte 6	Byte 7	Byte 8
0x18E8FFyy*	8	Control byte	0x00	Reserved		Address acknowledge	Request PGN		

* yy = source address

Transmission rate:

on request

DM 3 data

Byte 1	Control byte	Positive acknowledge:	0x00
		Busy:	0x02
Byte 2	0x00		
Byte 3	Reserved (FF)		
Byte 4			
Byte 5	Address acknowledge		
	Source address of requestor		
Byte 6	DM 3PGN (0x00FECC)		
Byte 7			
Byte 8			

PGN: Diagnostic Message 4

The Freeze Frame Parameters (abbreviated DM4) is used to trigger the PVED to transmit all current and previously active faults of a specific fault code stored in the diagnostic history onto the CAN bus.

Request frame format

Msg ID	DLC	Byte 1	Byte 2	Byte 3	Byte 4	Byte 5	Byte 6
0x18EAxxyy*	6	DM4 PGN LSB	DM4 PGN 2 nd byte	DM4 PGN MSB	SPN/FMI		
		0xCD	0xFE	0x00			

* xx = destination address (0x80-0x8F), yy = source address

Communication

Timeouts

- No message received by actuator after last packet was transmitted: 1250ms
- No message received by actuator after a hold the connection open message was received: 1050ms

Transmission rate: on request

DM4

Response frame format

No entries of the requested fault code

The actuator diagnostic history does not contain any record of the requested fault code.

Msg ID	DLC	Byte 1	Byte 2	Byte 3	Byte 4	Byte 5	Byte 6	Byte 7	Byte 8
0x18FECDyy*	8	0x00	0x00	0x00	0x00	0xFE	0xFF (Reserved)		

*yy = source address

Entries of requested fault code found

Actuator request to establish connection

Msg ID	DLC	Byte 1	Byte 2	Byte 3	Byte 4	Byte 5	Byte 6	Byte 7	Byte 8
0x1CECxyy*	8	Control byte	Total no of bytes with data available		Total no if packet	Number of packets that can be sent to one request**	Request PGN (DM4)		
		0x10					0xCD	0xFE	0x00

*xx = destination address (0x80-0x8F), yy = source address

** maximum number of packets that can be sent to one DM4 request = 8

Master ECU to establish connection

Msg ID	DLC	Byte 1	Byte 2	Byte 3	Byte 4	Byte 5	Byte 6	Byte 7	Byte 8
0x1CECxyy*	8	Control byte	Total no of packets can be sent**	Next packet no	Reserved		Request PGN (DM4)		
		0x11			0xFF	0xFF	0xCD	0xFE	0x00

*xx = destination address (0x80-0x8F), yy = source address

** Must be equal to byte 5 in the actuator request to establish connection – if master ECU is busy set to 0x00 meaning the connection is maintained open until timeout, but no data will be transmitted until new message arrives.

After the connection is established the PVED will transmit the content of the diagnostic history. The following frames will be sent for all occurrences of the enquired fault.

Communication

Diagnostic history frame format

Msg ID	DLC	Byte 1	Byte 2	Byte 3	Byte 4	Byte 5	Byte 6	Byte 7	Byte 8
0x1CEBxxyy*	8	Sequence no	Length	SPN/FMI			Occurrence / fault status	Fault ID	Operating time 1st occurrence
0x1CEBxxyy*	8	Sequence no	Operating time 1st occurrence cont.			Operating time last occurrence			
0x1CEBxxyy*	8	Sequence no	Environmental data for 1st fault record						
0x1CEBxxyy*	8	Sequence no							
0x1CEBxxyy*	8	Sequence no							
0x1CEBxxyy*	8	Sequence no							
0x1CEBxxyy*	8	Sequence no							
0x1CEBxxyy*	8	Sequence no							
0x1CEBxxyy*	8	Sequence no							
0x1CEBxxyy*	8	Sequence no							

* xx = destination address (0x80-0x8F), yy = source address

Diagnostic history data

Message 1	Byte 1	Sequence number							
	Byte 2	Freeze Frame Length							
	Byte 3	Fault information	Bits 24 to 6:			SPN of fault			
	Byte 4		Bits 5 to 1:			FMI of fault			
	Byte 5								
	Byte 6*	Occurrence count and current state							
		Bits 8 to 2:			Number of times the active fault has appeared previously				
		Bit 1:	Current state of the fault code			0 = previous fault 1 = currently active fault			
	Byte 7*	Fault ID							
	Byte 8*	Operating time of 1st occurrence of the fault (LSB)							
Message 2	Byte 1	Sequence number							
	Byte 2*	Operating time of 1 st occurrence of the fault							
	Byte 3*								
	Byte 4*								
	Byte 5*	Operating time of last occurrence of the fault							
	Byte 6*								
	Byte 7*								
	Byte 8*								
Message 3	Byte 1	Sequence number							
	Byte 2	Valve state upon fault occurrence							
	Byte 3	Set point at fault occurrence							
	Byte 4								
	Byte 5	Demand value at fault occurrence							
	Byte 6								
	Byte 7	Spool position at fault occurrence							
	Byte 8								

Communication

Diagnostic history data (continued)

Message 4	Byte 1	Sequence number
	Byte 2	Battery voltage
	Byte 3	
	Byte 4	Operating time
	Byte 5	
	Byte 6	
	Byte 7	
	Byte 8	Last spool position before fault occurrence
Message 5	Byte 1	Sequence number
	Byte 2	Last demand value before fault occurrence
	Byte 3	2 nd to last spool position before fault occurrence
	Byte 4	2 nd to last demand value before fault occurrence
	Byte 5	3 rd to last spool position before fault occurrence
	Byte 6	3 rd to last demand value before fault occurrence
	Byte 7	4 th to last spool position before fault occurrence
	Byte 8	4 th to last demand value before fault occurrence
Message 6	Byte 1	Sequence number
	Byte 2	5 th to last spool position before fault occurrence
	Byte 3	5 th to last demand value before fault occurrence
	Byte 4	6 th to last spool position before fault occurrence
	Byte 5	6 th to last demand value before fault occurrence
	Byte 6	7 th to last spool position before fault occurrence
	Byte 7	7 th to last demand value before fault occurrence
	Byte 8	8 th to last spool position before fault occurrence
Message 7	Byte 1	Sequence number
	Byte 2	8 th to last demand value before fault occurrence
	Byte 3	9 th to last spool position before fault occurrence
	Byte 4	9 th to last demand value before fault occurrence
	Byte 5	File number
	Byte 6	
	Byte 7	Line number
	Byte 8	
Message 8	Byte 1	Sequence number
	Byte 2	PCB temperature
	Byte 3	Reserved (0xFF)
	Byte 4	
	Byte 5	
	Byte 6	
	Byte 7	Checksum
	Byte 8	

* Fields are different from the J1939 standard

Communication

Master ECU to terminate connection upon receiving last packet with end of message acknowledge

Msg ID	DLC	Byte 1	Byte 2	Byte 3	Byte 4	Byte 5	Byte 6	Byte 7	Byte 8
0x1CECxyy*	8	Control byte	Total number of data bytes received		Total number of packets received	Reserved	Request PGN (DM4)		
		0x13				0xFF	0xCD	0xFE	0x00

*xx = destination address (0x80-0x8F), yy = source address

Abort connection

Both master ECU and PVED can abort the connection at any time

Abort message frame format

Msg ID	DLC	Byte 1	Byte 2	Byte 3	Byte 4	Byte 5	Byte 6	Byte 7	Byte 8
0x1CECxyy*	8	Control byte	Abort reason	Reserved			Request PGN (DM4)		
		0xFF		0xFF	0xFF	0xFF	0xCD	0xFE	0x00

*xx = destination address (0x80-0x8F), yy = source address

Abort message data

Byte 1	Control byte	0xFF
Byte 2	Abort reason	1: Already in one or more connections and cannot support another 2: System resources needed to perform other tasks - session terminated 3: Timeout occurred - session terminated
Byte 3	Reserved	0xFF
Byte 4		
Byte 5		
Byte 6	Request PGN (DM4)	0xCD
Byte 7		0xFE
Byte 8		0x00

PGN: Diagnostic Message 11

The Clear/Reset of Active Diagnostic Trouble Codes (abbreviated DM 11) is used as command along with two consecutive blocked states to recover to active state when the fault state has been entered due to a non-severe fault.

DM 11 support can be enabled/disabled by the PLUS+1® Service Tool.

Frame format

Request frame format

Msg ID	DLC	Byte 1	Byte 2	Byte 3
0x18EAxyy*	3	Request PGN LSB	Request PGN MSB	0x00
		0xD3	0xFE	

*x = destination address (0x80-0x8F), yy = source address

Communication

Answer frame format

Msg ID	DLC	Byte 1	Byte 2	Byte 3	Byte 4	Byte 5	Byte 6	Byte 7	Byte 8
0x18E8FFyy*	8	Control byte	0x00	Reserved		Address acknowledge	Request PGN		

*yy = source address

Transmission rate:

on request

DM 11 data

Byte 1	Control byte	Positive acknowledge:	0x00
		Negative acknowledge:	0x01
Byte 2	0x00		
Byte 3	Reserved (FF)		
Byte 4			
Byte 5	Address acknowledge		
	Source address of requestor		
Byte 6	DM 11 PGN (0x00FED3)		
Byte 7			
Byte 8			

PGN: Diagnostic Message 13

The Start Diagnostics message (abbreviated DM 13) is used to bring the PVED from Inactive Control State to full operational mode.

DM 13 support can be enabled/disabled by the PLUS+1® Service Tool.

Frame format

Request frame format

Msg ID	DLC	Byte 1	Byte 2	Byte 3	Byte 4	Byte 5	Byte 6	Byte 7	Byte 8
0x18DFFFyy*	8	Network type	Reserved						
		0xFD							

*yy = source address

Transmission rate:

on request

Parameters

Parameter overview

The following parameters can be configured within a PVED-CC Series 5 ISOBUS to tailor the behavior to the exact need of the function which it controls. All parameters can be changed using the PLUS+1[®] Service Tool.

Parameter overview

Parameter	Description	Range	Default
NodeID (source address)	Source address of the PVED	128 - 143	128
		0x80-0x8F	0x80
Vehicle serial number	Free fields to enter vehicle serial number or other machine specific data	free (23 positions)	blank
Scaling of port flow command* - Extend	Scaling of the spool stroke. 100% scaling = 7mm spool stroke	Resolution: 0.4%	
		0-100%	100%
		0-250	250
		0x00-0xFA	0xFA
Scaling of port flow command* - Retract	Scaling of the spool stroke. 100% scaling = 7mm spool stroke	Resolution: 0.4%	
		0-100%	100%
		0-250	250
		0x00-0xFA	0xFA
Dead band offset* - Extend	Spool stroke when given a PFC of 1. Dead band offset is superimposed on top of the spool curve dead band jump.	0-100%	0
		0x00-0x64	0x00
Dead band offset* - Retract	Spool stroke when given a PFC of 1. Dead band offset is superimposed on top of the spool curve dead band jump.	0-100%	0
		0x00-0x64	0x00
Progressivity curve* - Extend	Pre-defined curves to change flow from linear to progressive	1-16	1
Progressivity curve* - Retract	Pre-defined curves to change flow from linear to progressive	1-16	1
Ramp up* - Extend	Time to stroke spool from neutral to full stroke. Full stroke is defined by the scaling parameter.	Resolution: 16 ms	
		0-4000 ms	0 ms
		0-250	0
		0x00-0xFA	0x00
Ramp down* - Extend	Time to stroke spool from full stroke to neutral. Full stroke is defined by the scaling parameter	Resolution: 16 ms	
		0-4000 ms	0 ms
		0-250	0
		0x00-0xFA	0x00
Ramp up* - Retract	Time to stroke spool from neutral to full stroke. Full stroke is defined by the scaling parameter	Resolution: 16 ms	
		0-4000 ms	0 ms
		0-250	0
		0x00-0xFA	0x00
Ramp down* - Retract	Time to stroke spool from full stroke to neutral. Full stroke is defined by the scaling parameter	Resolution: 16 ms	
		0-4000 ms	0 ms
		0-250	0
		0x00-0xFA	0x00
Invert ports*	Inverts PFC	Inverted/not inverted	Not inverted

Parameters

Parameter overview (continued)

Parameter	Description	Range	Default
Power Save	Reduce power consumption by making the PVED enter a sleep mode when in neutral. Time delay configurable	ON/OFF	ON
Power save entry delay	Time the spool has to stay in neutral position before power save mode is entered	Resolution: 100 ms	
		0-8000 ms	500 ms
		0-80	50
		0x00-0x50	0x32
Low voltage reaction delay	Time from voltage drops below acceptable limit (9VDC) to the DM1 is transmitted	Resolution: 100 ms	
		0-2000 ms	1000 ms
		0-20	10
		0x00-0x14	0x0A
AVEF transmit time	How often is the AVEF transmitted onto the bus	Resolution: 1 ms	
		0-10000 ms	100 ms
		0-10000	100
		0x00-0x2710	0x64
AVC timeout	Timeout period for receiving the AVC message from the master	Resolution: 1 ms	
		0-10000 ms	300 ms
		0-10000	300
		0x00-0x2710	0x12C
Support DM13	Choose whether or not Start Diagnostics (DM13 message) is required to have the PVED operate	Enable/disable	Disable
Float ramp time	Time to stroke the spool from full flow to float position	Resolution: 1 ms	
		0-500 ms	0 ms
		0-500	0
		0x00-0x1F4	0x00
Float threshold*	Minimum PFC needed to be received by the PVED before allowed to enter float	Resolution: 0.4%	
		0-100%	0%
		0-250	0
		0x00-0xFA	0x00
Support DM11	Choose whether or not Reset of Active DTCs (DM11) is required to leave fault state	Enable/disable	Enable
Temperature dependent spool timeout	Allowed time to stroke the spool from full stroke to neutral for in a 10 °C temperature interval from -40 to +130 °C	Resolution: 100 ms	
		0-25500 ms	See graph below
		0-255	
		0x00-0xFF	
Temperature dependent spool timeout float add-on	Time added to temperature dependent timeout to reach float position	Resolution: 1%	
		0-100%	100%
		0-255	255
		0x00-0xFF	0xFF
DM1 status transmission	Transmission of DM1 message will occur either as status each 1000 ms or by fault event	Status message / event triggered	Status message
Enable KWP2000	Enable actuator to respond to KWP2000 protocol messages	Enable/disable	Enable
KWP2000 ID	Respond to global or specific KWP2000 messages	Global/specific	Global

Parameters

Parameter overview (continued)

Parameter	Description	Range	Default
KWP2000 message timeout	Timeout period for receiving KWP2000 message from the master	Resolution: 1 sec	
		0-255 sec	5 sec
		0-255	5
		0x00-0xFF	0x05
Reserved bits in AVEF byte 3	Chooses whether the reserved bits in byte 3 of AVEF is 0 or 1	0/1	1

* Part of Process Data and can be modified at runtime.

Timeout as a function of temperature

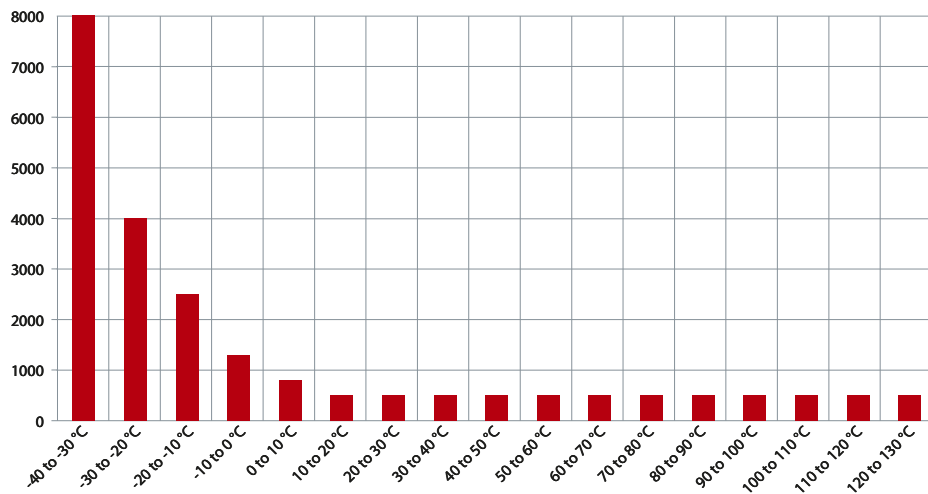

P301 824A

PVED-CC ISOBus Process data

Process Data is part of the parameters in the PVED-CC Series 5 ISOBUS. These data can be changed at runtime using the CAN bus messages shown.

Process data messages

Message ID	Message type	DLC	Control Byte (Byte 1)
0x0CCBxyy*	Write Command	8	0x00
0x0CCBxyy*	Read Command	8	0x10

* xx = destination address (0x80-0x8F), yy = source address

Process data overview

Data Dictionary column	Process Data Parameter
0	Scaling of PFC – Extend
1	Scaling of PFC – Retract
3	Progressivity Curve – Extend
4	Dead band Offset – Extend
5	Dead band Offset – Retract
6	Progressivity Curve – Retract
8	Ramp up – Extend

Parameters

Data Dictionary column	Process Data Parameter
9	Ramp down – Extend
10	Ramp up – Retract
11	Ramp down – Retract
12	Invert ports
13	Float Threshold
14	Commit to EEPROM
15	Restore Factory Settings

Setpoint transfer feature: Write process data

The write process data will change the behavior of the PVED, and thereby the valve, at runtime by changing the value of a given parameter.

Frame format

Write frame format

Msg ID	DLC	Byte 1	Byte 2	Byte 3	Byte 4	Byte 5	Byte 6	Byte 7	Byte 8
0x0CCBxyy*	8	Control Byte	Count number	Implement type and position	Data dictionary row / column	Process data variable parameters		Not used	

* xx = destination address (0x80-0x8F), yy = source address

Write data

Byte 1	Control Byte (0x00)
Byte 2	Count number (0x00)
Byte 3	Implement type and position (0x00)
Byte 4	Data dictionary
	Bits 8-5: Data dictionary row (0x06) Bits 4-1: Data dictionary column
Byte 5	Process data variable (0x00)
Byte 6	
Byte 7	Not used by PVED (0x00)
Byte 8	

Linked fault flags

Fault	SPN	FMI
Process data out of range	298983	2
Process data out of range at boot-up	520579	2

Read frame format

Msg ID	DLC	Byte 1	Byte 2	Byte 3	Byte 4	Byte 5	Byte 6	Byte 7	Byte 8
0x0CCCxyy*	8	Control Byte	Count number	Implement type and position	Data dictionary row / column	Process data variable parameters		Not used in PVED	

* xx = source address

Transmission rate:

on request

Parameters

Read data

Byte 1	Control Byte (0x10)		
Byte 2	Count number (0x00)		
Byte 3	Implement type and position (0x00)		
Byte 4	Data dictionary	Bits 8-5:	Data dictionary row (0x06)
		Bits 4-1:	Data dictionary column
Byte 5	Process data variable		
Byte 6			
Byte 7	Not used by PVED (0x00)		
Byte 8			

Diagnostics

PVED-CC (ISOBus) Diagnostics log

The PVED-CC Series 5 contains a diagnostic log saving the occurrence of all faults listed below (sorted in ascending order by SPN). The faults are transmitted onto the CAN bus through the DM1 message upon occurrence and previously active faults can be enquired through the DM2 message. The complete list of active and previously active faults can be seen in the PLUS+1® Service Tool.

Diagnostics log

Fault ID	Fault	Description	SPN	FMI	Severity	SPN + FMI byte values as seen in DM1/DM2 frames		
						Byte 3	Byte 4	Byte 5
4	Supply voltage above upper limit	Actuator supply voltage above specified upper limit. Please ensure sufficient power supply.	627	3	WARNING	0x73	0x02	0x03
5	Supply voltage below lower limit	Actuator supply voltage below specified lower limit. Please ensure sufficient power supply.	627	4	WARNING	0x73	0x02	0x04
34	Memory (flash) corrupted	Actuator component fault.	628	12	SEVERE	0x74	0x02	0x0C
32	Memory (RAM) corrupted	Actuator component fault.	1557	12	SEVERE	0x15	0x06	0x0C
42	PSM buffer overload	Actuator component fault.	298965	11	SEVERE	0xD5	0x8F	0x8B
39	PSM operation fault	Actuator component fault.	298966	11	SEVERE	0xD6	0x8F	0x8B
57	Loss and recovery of CAN bus connection	CAN bus connection to the actuator failed but recovered. Please verify connection.	298967	19	WARNING	0xD7	0x8F	0x93
3	Interpolation fault	Actuator component fault.	298968	11	SEVERE	0xD8	0x8F	0x8B
53	Commit-to-EEPROM invalid cmd.	Command Commit-to-EEPROM out of valid range.	298983	2	INFO	0xE7	0x8F	0x82
58	AVC not recieved within timeout period	Auxillary Valve Command not recived by actuator before timeout specified	298985	19	WARNING	0xE9	0x8F	0x93
61	Float threshold set point not given	Setpoint less than float threshold given when commanded into float position.	298986	19	WARNING	0xEA	0x8F	0x93
49	Actual main spool position exceeds set point recieved.	Main spool stroke further away from neutral than demanded by setpoint. (Dependent on timeout value).	298988	7	CRITICAL	0xEC	0x8F	0x87
48	Main spool not in neutral at boot up.	Main spool not at neutral position in the module at time of bootup.	298989	7	CRITICAL	0xED	0x8F	0x87
47	Float not reached.	Main spool cannot reach float position.	298990	7	CRITICAL	0xEE	0x8F	0x87
29	POST fault	Power On Self-Test failed. Actuator cannot start up.	298992	12	SEVERE	0xF0	0x8F	0x8C
27	Handshake bootup fault.	Actuator component fault.	298993	11	SEVERE	0xF1	0x8F	0x8B
63	Stack usage >90%	Actuator component fault.	298996	2	CRITICAL	0xF4	0x8F	0x82
62	Solenoid driver validation fault	Actuator component fault.	298997	2	CRITICAL	0xF5	0x8F	0x82
35	Memory (EEPROM) communication fault	Actuator component fault.	299001	12	CRITICAL	0xF9	0x8F	0x8C
2	Parameter truncation change	Value of parameter changed due to truncation.	299002	11	SEVERE	0xFA	0x8F	0x8B
1	Internal calculation fault	Actuator component fault.	299004	11	SEVERE	0xFC	0x8F	0x8B
0	Software Initialisation fault	Software could not initialize. Check that no active errors are present on CAN bus.	299005	11	SEVERE	0xFD	0x8F	0x8B
12	Handshake not received by safeUC	Actuator component fault.	299007	11	SEVERE	0xFF	0x8F	0x8B
13	Transducer signal frequency out of range.	Actuator component fault.	299008	8	SEVERE	0x00	0x90	0x88

Diagnosics

Diagnosics log (continued)

Fault ID	Fault	Description	SPN	FMI	Severity	SPN + FMI byte values as seen in DM1/DM2 frames		
						Byte 3	Byte 4	Byte 5
14	Safety demodulator A: signal out of range	Actuator component fault.	299009	2	SEVERE	0x01	0x90	0x82
16	Safety-controller PSU out of range	Actuator component fault.	299010	2	SEVERE	0x02	0x90	0x82
18	Safety-controller fuse bit fault	Actuator component fault.	299011	2	SEVERE	0x03	0x90	0x82
15	Safety demodulator B: signal out of range	Actuator component fault.	299012	2	SEVERE	0x04	0x90	0x82
17	Safety-controller: Voltage reference out of range	Actuator component fault.	299013	2	SEVERE	0x05	0x90	0x82
19	Safety-controller spool position cross validation fault	Actuator component fault.	299014	2	SEVERE	0x06	0x90	0x82
20	Safety switch state fault	Actuator component fault. Not able to perform safe operation!	299015	12	SEVERE	0x07	0x90	0x8C
51	SPI buffer overload	Actuator component fault.	299020	2	INFO	0x0C	0x90	0x82
52	SPI communication fault	Actuator component fault.	299021	2	SEVERE	0x0D	0x90	0x82
25	Handshake bootup fault.	Actuator component fault.	299022	12	SEVERE	0x0E	0x90	0x8C
26	Safety switch state fault.	Actuator component fault.	299023	12	SEVERE	0x0F	0x90	0x8C
31	Spool position cross validation fault	Actuator component fault.	299025	2	SEVERE	0x11	0x90	0x82
28	Safety-controller initialization fault.	Actuator component fault.	299026	12	WARNING	0x12	0x90	0x8C
30	Safety-controller task scheduling fault	Actuator component fault.	299028	12	SEVERE	0x14	0x90	0x8C
38	Memory (EEPROM) corrupted	Actuator component fault.	299029	12	SEVERE	0x15	0x90	0x8C
64	CRC fault	The Operator has not approved the data change	299030	2	SEVERE	0x16	0x90	0x82
65	Invalid hardware version.	Actuator component fault.	520448	2	SEVERE	0x00	0xF1	0xE2
56	AVEF from Work Function actuators not recieved within timeout period	Auxillary Valve Estimated Flow not recieved from Work Function actuators by Inlet actuator before timeout specified	520449	19	WARNING	0x01	0xF1	0xF3
55	Corrupted data received by Inlet actuator	CRC or DLC data received from Inlet actuator is corrupted	520450	19	CRITICAL	0x02	0xF1	0xF3
54	COMM : Running number validation for AVC and AVEF	The running number for Auxillary Valve Command nd Auxillary Valve Estimated Flow could not be validated.	520451	19	CRITICAL	0x03	0xF1	0xF3
41	Memory (EEPROM) CRC fault	Actuator component fault.	520576	2	INFO	0x80	0xF1	0xE2
37	PWM calibration	Actuator component fault.	520577	2	SEVERE	0x81	0xF1	0xE2
40	Config sector CRC fault	Actuator component fault.	520578	2	SEVERE	0x82	0xF1	0xE2
33	Memory (EEPROM) invalid parameter	One or more configured EEPROM parameters out of specified range.	520579	2	SEVERE	0x83	0xF1	0xE2
43	Average operating temp above limit.	The average detected operating temperature is above the upper limit specified.	520580	16	WARNING	0x84	0xF1	0xF0
44	Current temp above upper limit.	The current temperature the actuator operates in is above specified operation limit.	520581	0	CRITICAL	0x85	0xF1	0xE0
6	5V PSU out of range	Actuator component fault.	520582	2	SEVERE	0x86	0xF1	0xE2
7	Spool position calculation fault	Actuator component fault.	520583	2	SEVERE	0x87	0xF1	0xE2
50	LVDT supply frequency out-of-range	Actuator component fault.	520584	2	SEVERE	0x88	0xF1	0xE2
8	V reference signal out of range.	Actuator component fault.	520585	2	SEVERE	0x89	0xF1	0xE2

Diagnostics

Diagnostics log (continued)

Fault ID	Fault	Description	SPN	FMI	Severity	SPN + FMI byte values as seen in DM1/DM2 frames		
						Byte 3	Byte 4	Byte 5
9	GND signal unstable.	Actuator component fault.	520586	3	SEVERE	0x8A	0xF1	0xE3
60	Safety switch state fault	Actuator component fault. Not able to perform safe operation!	520587	12	SEVERE	0x8B	0xF1	0xEC
10	Demodulator A: signal out of range	Actuator component fault.	520588	2	SEVERE	0x8C	0xF1	0xE2
11	Demodulator B: signal out of range	Actuator component fault.	520589	2	SEVERE	0x8D	0xF1	0xE2
45	Current temp below lower limit.	The current temperature the actuator operates in is below specified operation limit.	520590	1	CRITICAL	0x8E	0xF1	0xE1
46	Main spool cannot return to neutral	Main spool cannot return back to neutral by neutral command setpoint.	520591	7	CRITICAL	0x8F	0xF1	0xE7
36	Fault overload	More than three faults were raised simultaneously.	520592	0	SEVERE	0x90	0xF1	0xE0
59	AVC data recieved invalid	Auxillary Valve Command input recieved by actuator. Invalid state and/or flow request sent from controller.	520676	19	WARNING	0xE4	0xF1	0xF3

With occurrence of severe faults the actuator must always be repowered.

With multiple occurrences of severe faults replace actuator.

Diagnostic history

In addition to the diagnostic log, the PVED-CC Series 5 holds a record of the last 16 faults occurred. The faults are stored in a FIFO buffer.

Besides the fault code the history also contains more information on the behavior and state of the valve upon fault occurrence. The diagnostic history can be seen in the PLUS+1[®] Service Tool.

Parameter	Description
Fault ID	ID number of the fault raised
Valve State	State of device upon fault occurrence
Current set point	Set point upon fault occurrence
Current spool position	Spool position upon fault occurrence
Battery voltage	Battery voltage upon fault occurrence
Operating time	Operating time upon fault occurrence*
Setpoint and spool position history	Last 9 setpoint and spool positions prior to fault occurrence
Temperature	Temperature upon fault occurrence [†]

* Operating time is logged every 6 minutes when the power to the PVED is ON

† Temperature is either received through PGN: VFT or onboard PCB temperature sensor

Temperature histogram

The PVED-CC Series 5 logs the temperature and time each 6 minutes. This temperature record is used to make a temperature histogram.

The temperature used is the one received in the PGN: Vehicle Fluid Temperature. If no PGN:VFT is received the PVED uses the onboard PCB temperature sensor.

The Temperature Histogram can be seen in the PLUS+1[®] Service Tool.

Products we offer:

- DCV directional control valves
- Electric converters
- Electric machines
- Electric motors
- Gear motors
- Gear pumps
- Hydrostatic motors
- Hydrostatic pumps
- Orbital motors
- PLUS+1® controllers
- PLUS+1® displays
- PLUS+1® joysticks and pedals
- PLUS+1® operator interfaces
- PLUS+1® sensors
- PLUS+1® software
- PLUS+1® software services, support and training
- Position controls and sensors
- PVG proportional valves
- Steering components and systems
- Telematics

Danfoss Power Solutions is a global manufacturer and supplier of high-quality hydraulic and electric components. We specialize in providing state-of-the-art technology and solutions that excel in the harsh operating conditions of the mobile off-highway market as well as the marine sector. Building on our extensive applications expertise, we work closely with you to ensure exceptional performance for a broad range of applications. We help you and other customers around the world speed up system development, reduce costs and bring vehicles and vessels to market faster.

Danfoss Power Solutions – your strongest partner in mobile hydraulics and mobile electrification.

Go to www.danfoss.com for further product information.

We offer you expert worldwide support for ensuring the best possible solutions for outstanding performance. And with an extensive network of Global Service Partners, we also provide you with comprehensive global service for all of our components.

Hydro-Gear

www.hydro-gear.com

Daikin-Sauer-Danfoss

www.daikin-sauer-danfoss.com

Local address:

**Danfoss
Power Solutions (US) Company**
2800 East 13th Street
Ames, IA 50010, USA
Phone: +1 515 239 6000

**Danfoss
Power Solutions GmbH & Co. OHG**
Krokamp 35
D-24539 Neumünster, Germany
Phone: +49 4321 871 0

**Danfoss
Power Solutions ApS**
Nordborgvej 81
DK-6430 Nordborg, Denmark
Phone: +45 7488 2222

**Danfoss
Power Solutions Trading
(Shanghai) Co., Ltd.**
Building #22, No. 1000 Jin Hai Rd
Jin Qiao, Pudong New District
Shanghai, China 201206
Phone: +86 21 2080 6201

Danfoss can accept no responsibility for possible errors in catalogues, brochures and other printed material. Danfoss reserves the right to alter its products without notice. This also applies to products already on order provided that such alterations can be made without subsequent changes being necessary in specifications already agreed. All trademarks in this material are property of the respective companies. Danfoss and the Danfoss logotype are trademarks of Danfoss A/S. All rights reserved.