

Technical Information

PVEA-CI and PVEO-CI Series 6 Electro-hydraulic Actuators



Revision history*Table of revisions*

Date	Changed	Rev
July 2018	Heartbeat message node change.	0106
May 2018	add use case 5 and 6	0105
Oct 2017	Minor edits	0104
Jun 2017	Appended Accessory table	0103
September 2015	Updated EMCY message table	0102
November 2015	Changing Node ID corrected	0001
June 2015	First edition	0000

Contents

PVEA-CI and PVEO-CI Introduction

Configurable parameters.....	5
PVE-CI Communication.....	6
PVEA-CI and PVEO-CI connector.....	7
Accessory.....	7

ISOBUS/J1939 Communication Protocol

Parameter Group Number (PGN).....	8
Auxiliary Valve Command (AVC).....	8
Auxiliary Valve Estimated Flow (AVEF).....	9
PVE-CI Diagnostics.....	10
Diagnostic Message 1 (DM1).....	10
Diagnostic Message 2 (DM2).....	11
Broadcast Announce Message (BAM).....	12
Diagnostic Message 3 (DM3).....	12
Changing Node ID.....	12
Commanded address according to ISOBUS/J1939	13
PVE-CI Address claim.....	13
Address claim request.....	14
Commanded address (ISOBUS/J1939).....	14
ISOBUS/J1939 error codes.....	15

CANopen Communication Protocol

NMT operations.....	17
Boot-up protocol.....	18
NMT services supported.....	18
State feedback values.....	19
LSS slave.....	20
PVE-CI switch state global.....	20
PVE-CI switch state selective.....	21
Configure Node ID.....	22
Configure bit timing parameters.....	22
Activate bit timing parameters.....	23
PVE-CI store configurations.....	23
PVE-CI identify non-configured remote slave.....	24
Identify non-configured slave.....	24
Fast scan.....	24
State behavior.....	24
PVE-CI heartbeat protocol.....	25
Fault handling.....	25
PDO mapping procedure.....	26
Object dictionary - communication profile.....	26
Device type.....	26
Error register.....	26
Predefined error field.....	26
COB-ID SYNC.....	27
Manufacturer software version.....	27
Store parameters.....	27
Restore default parameters.....	28
COB-ID EMCY.....	29
Producer heartbeat time.....	29
Identity object.....	29
PVE-CI emergency consumer.....	29
RPDO parameter.....	29
RPDO mapping.....	30
TPDO parameter.....	30
TPDO mapping.....	30
Object dictionary	30
Standardized device profile.....	30
Unified Diagnostic Services (UDS) lite.....	32

Contents

UDS - message ID formation.....	32
UDS – read data by identifier.....	32
UDS – write data by identifier.....	33
UDS – change Node ID	34
UDS – ECU identification.....	35

PVEA-CI Series 6 diagnostics

LED Characteristic.....	36
-------------------------	----

Use cases

Use case 1 - Boot-up to operation mode.....	37
Use case 2 - Operation Mode – Error – Operation Mode.....	37
Use case 3 - Change Node ID globally.....	38
Use case 4 - Change Node ID for specific Node.....	39
Use Case 5 – Change of baud rate 250 kbit/s to 500 kbit/s:.....	41
Use Case 6 – Align cob-id to new configured node id:.....	42

PVEA-CI and PVEO-CI Introduction

The PVEA-CI and PVEO-CI Series 6 are digitally controlled actuators for the PVG 16 family based on the hydraulic concept known from the analog versions of PVEA and PVEO Series 6.

PVEA-CI and PVEO-CI Series 6



F500 271

Communication protocols available for PVE-CI:

- ISO 11783 part 7
- J1939-21, -71, -73, -81

CANopen according to:

- CiA 301 version 4.2.0
- CiA 305 version 1.5.2
- CiA 408 version 3.0.0

Configurable parameters

Choose and configure the following parameters for the PVE-CI in order to fit into your system.

J1939/ISObus

PVE-CI type	PVEO-CI	PVEA-CI
Part number	11124002	11121945
Node ID range	0x80-0x8F (128-143)	

PVEA-CI and PVEO-CI Introduction

CANopen

PVE-CI type	PVEO-CI	PVEA-CI
Part number	11149443	11149437
Node ID range	0x01-0x7F (1-127)	
Heartbeat default	0x00 = off	
Heartbeat range	0x00-0x7FFF (0-32767) *	
COB-ID SYNC default	0x80**	
TPDO transmission default	0xFF event driven	
TPDO transmission range	0x07-0xF0 (1-240)***	

* For more information see [PVE-CI heartbeat protocol](#) on page 25.

** For more information see [COB-ID SYNC](#) on page 27.

*** For more information see [TPDO parameter](#) on page 30.

PVE-CI Communication

The Controller Area Network or simply the CAN bus is an intelligent and efficient bus communication where highly important messages have priority without any delaying message collisions.

The PVE-CI is available with ISOBUS/SAE J1939 baud rate fixed to 250 Kbps or CANopen default baud rate = 250 Kbps.

The following states are valid in both communication protocols:

- Blocked**
- The spool and the two normally closed solenoid valves inside the actuator (PVE) are in neutral position.
 - The actuator (PVE) will enter power save mode after 200 ms in blocked state.
 - Power Save mode de-energizes the solenoids, while being in blocked state. As soon as a non-neutral set-point is received by the actuator (PVE) or the spool is moved the Power Save mode is aborted.

The blocked position is considered to be the safe state for the PVE and valve.

- Extend**
- The extend direction is defined as the spool moving away from the PVE and entering the B-port side.
 - The feedback signal equals positive values.

- Retract**
- The retract direction is defined as the spool moving towards the actuator and entering the A-port side.
 - The feedback signal equals negative values.

- Float**
- The float state is defined as the spool being actuated fully in the side of the B-port.
 - When float position is achieved both A- and B-ports are connected to tank in order to allow oil flow back and forwards between tank and the work port connections.

- Hand operation**
- Hand operation mode will de-activate the solenoid valves inside the PVE.
 - The feedback signal will be transmitted when the spool is moved manually e.g. by a lever.
 - Any failures related to the spool position are ignored and will not be transmitted nor logged by internal diagnostics. The introduction of any other failures will result in a normal reaction and recovery pattern where a DM1 message is transmitted, etc.

PVEA-CI and PVEO-CI Introduction

Emergency stop Solenoid is disabled.

PVEA-CI and PVEO-CI connector

1 x 4 pin DEUTSCH

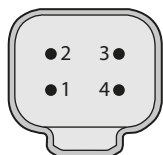

4-pin layout

1. CAN_High
2. CAN_Low
3. V_{BAT}
4. V_{NEG}

Accessory

Description	Code Number
Loop cable 100mm, DEUTSCH 4-PIN	11007531
Loop cable 175mm, DEUTSCH 4-PIN	11095622
Loop cable 350mm, DEUTSCH 4-PIN	11111916
Cable 4000mm, DEUTSCH 4-PIN	11095741
Seal kit for PVE-CI	11133165
Seal kit for PVM	157B3999
CG 150-2* (CAN gateway)	11153051
Termination Dummy	11007563
120 Ω terminator	11007561

* Only to be used with PLUS+1® Service Tool version 7.1.10 or newer.

ISOBUS/J1939 Communication Protocol

Parameter Group Number (PGN)

Parameter group number overview

PGN (hex)	Message type	DLC	Translation	Timing
0x0CFE3x yy*	AVC	8	Auxillary Valve Command	250 ms fixed timeout **
0x0CFE1x yy*	AVEF	8	Auxillary Valve Estimated Flow	Transmission rate: 100 ms
0x18FECA	DM1	8	Active fault	1000 ms/event based
0x18FECB	DM2	8	Request previous active faults	On request
0x18EA00	DM3	3	Clear error log	On request

* x = Node ID (0x80-0x8F), yy = Source address

** A time guarding error will occur if the PVE does not see a AVC within 250 ms.

Auxiliary Valve Command (AVC)

The **Auxiliary Valve Command** (AVC) is the command value sent from a master controller to control the PVE. Message that provides control of the flow through the auxiliary valve number 0.

Data length	8 bytes
Data page	0
PDU format	254
PDU specific	48
Default priority	3
Parameter group number	65072 (00FE30 ₁₆)
Transmission repetition rate	100 ms between messages for each valve or when a parameter is required to change state

The PVE will only accept messages with correct Node ID and ignore any AVC commands if invalid.

Frame format

Msg ID	DLC	Byte 1	Byte 2	Byte 3	Byte 4	Byte 5	Byte 6	Byte 7	Byte 8
CFE3xxx	8	PFC	Reserved	Valve state	Reserved				

AVC data

Byte 1	Byte 2	Byte 3	Byte 4	Byte 5	Byte 6	Byte 7	Byte 8
PFC	Reserved (FF)	Valve state					Reserved (FF)

Port Flow Command (PFC)

Request port flow as a percentage of full flow. PFC = 0 is interpreted as a neutral command.

Resolution: 0.4% per bit

Valid range: 0 → 100%; 0 → 250; 0x00 – 0xFA

Valve state

In blocked state the value in PFC is ignored.

ISOBUS/J1939 Communication Protocol

- Bits 8 and 7: Fail safe mode – only blocked (0x00) supported
- Bits 6 and 5: Reserved
- Bits 4 to 1:
 - Block (neutral) = 0b0000
 - Extend = 0b0001
 - Retract = 0b0010
 - Float = 0b0011
 - Hand operation = 0b1010
 - Emergency stop = 0b1110

Auxiliary Valve Estimated Flow (AVEF)

The Auxiliary Valve Estimated Flow (AVEF) is the feedback sent from the PVE-CI to the master controller telling the assumed flow/spool position. Message that provides the estimated flow of auxiliary valve number 0.

Data length	8 bytes
Data page	0
PDU format	254
PDU specific	16
Default priority	3
Parameter group number	65040 (00FE10 ₁₆)
Transmission repetition rate	100 ms (from PVE)

Frame format

Msg ID	DLC	Byte 1	Byte 2	Byte 3	Byte 4	Byte 5	Byte 6	Byte 7	Byte 8
CFE1xxx	8	Extend port flow	Retract port flow	Valve state	Reserved				

AVEF data

Byte 1	Byte 2	Byte 3	Byte 4	Byte 5	Byte 6	Byte 7	Byte 8
EPF	RPF	Valve state	Reserved				

Extend Port Flow (EPF)

Estimated flow out of extend port as a percentage of full flow.

- Resolution: 1% per bit
- Offset: 125; 0x7D
- Valid range: 0 → 100%; 125 → 225;

Retract Port Flow (RPF)

Estimated flow out of retract port as a percentage of full flow.

- Resolution: 1% per bit
- Offset: 125; 0x7D
- Valid range: 0 → 100%; 125 → 225; 0x7D - 0xE10x7D - 0xE1

Valve state

In blocked state the value in PFC is ignored.

ISOBUS/J1939 Communication Protocol

- 0x7D -Bits 8 and 7: Fail safe mode – only blocked (0x00) supported
- Bits 6 and 5: Reserved
- Bits 4 to 1:
 - Block (neutral) = 0b0000
 - Extend = 0b0001
 - Retract = 0b0010
 - Float = 0b0011
 - Hand operation = 0b1010
 - Emergency stop = 0b1110

No additional system related information will be transmitted in the AVEF.

PVE-CI Diagnostics

The following error codes are available on the bus from the PVE-CI:

Error codes

Priority	Error	DTC (Diagnostic trouble code)	Source of Error	Lamp Status	Regulation	Recovery
1	Spool not at set point	0x878FEC	External	Critical	Shutdown	Two neutral set-points and spool in neutral
2	Spool cannot reach float	0x878FEE	External	Critical	Shutdown	Two neutral set-points and spool in neutral
3	Internal Error	0x8B8FFA	Internal	Severe	Shutdown	Two neutral set-points and spool in neutral
4	CAN bus Error	0x938FD7	External	Warning	Shutdown	Two neutral set-points and spool in neutral
5	Temperature Error (120°C in 250 ms)	0x908FF1	External	Warning	Shutdown	Two neutral set-points and spool in neutral
6	Power supply exceeds specification (36 V _{DC} for 2000 ms)	0x030273	External	Warning	Shutdown	Two neutral set-points and spool in neutral
7	Power supply is below specification (9 V _{DC} for 2000 ms)	0x040273	External	Warning	Shutdown	Two neutral set-points and spool in neutral
8	Time guarding error	0x938FE9	External	Warning	Shutdown	Two neutral set-points and spool in neutral

CAN bus Error If there is a bus-off situation the LED will turn red and a DM1 message will be generated. However the message cannot be send due to the bus-off and the application controller will not receive a DM1 message in the event of this error. The PVEA-CI will contribute on the bus again when the bus-off situation is gone.

Diagnostic Message 1 (DM1)

The active troubleshooting code **Diagnostic Message 1 (DM1)** is used by the PVE-CI to transmit an active fault onto the CAN bus. The PVE-CI will broadcast one fault at a time on the CAN bus. The highest error priority will be the one broadcasted.

PGN	0x18CEFA
Transmission timing rate	1000 ms or event based
Maximum of faults	127

ISOBUS/J1939 Communication Protocol

The DM 1 messages will still be transmitted after the occurrence of the 127th fault, but the fault counter will not increment.

DM1 frame format

Msg ID	DLC	Byte 1	Byte 2	Byte 3	Byte 4	Byte 5	Byte 6	Byte 7	Byte 8
18CEFAyy*	8	Lamp status	Flash status	Fault information			Occurrence counter	Reserved	

*yy = Source address.

Lamp status

Used by controller – not related to the LED.

- No fault (default state): 0x00
- Warning type faults–Amber lamp: 0x04
- Critical or severe type faults–Red lamp: 0x10

Flash status

Used by controller – not related to LED. Flashing: 0xFF

Fault information

- Bits 24 to 6: SPN of active fault
- Bits 5 to 1: FMI if active fault

Occurrence counter

Number of times the active fault has appear previously.

Diagnostic Message 2 (DM2)

The Previous active trouble code **Diagnostic Message 2 (DM2)** is used by the controller to command the PVE-CI to transmit all previously active faults.

PGN	0x18CEFB
Transmission timing rate	On request
Maximum of faults	127

DM2 frame format

Msg ID	DLC	Byte 1	Byte 2	Byte 3	Byte 4	Byte 5	Byte 6	Byte 7	Byte 8
18CEFCBxx	8	Lamp status	Flash status	Fault information			Occurrence counter	Reserved	

Lamp status

Used by controller – not related to the LED.

- Info or Warning type faults–Amber lamp: 0x04
- Critical or severe type faults–Red lamp: 0x10

Flash status

Used by controller – not related to LED. Flashing: 0xFF

Fault information

- Bits 24 to 6: SPN of active fault
- Bits 5 to 1: FMI if active fault

Occurrence counter

Number of times the active fault has appear previously.

ISOBUS/J1939 Communication Protocol

Broadcast Announce Message (BAM)

The frame format will be in **Broadcast Announce Message (BAM)** if more than one single fault occurs. The BAM message size depends on the number of previously active faults.

BAM frame format

BAM	Msg ID	DLC	Byte 1	Byte 2	Byte 3	Byte 4	Byte 5	Byte 6	Byte 7	Byte 8
	1CECFFxx	8	BAM	No. of bytes		No. of packets	Reserved	DM2 PGN (0x00FECB)		
DT1	1CEBFFxx	8	Sequence	Lamp status	Reserved	Fault 1			Fault 2	
DT2	1CEBFFxx	8	Sequence	Fault 2 cont.		Fault 3				
DT3	1CEBFFxx	8	Sequence	Fault 4				BAM continued		

Number of packets

How many messages are sent in the complete BAM.

Sequence

Identification number of the BAM message in the BAM sequence.

Lamp status

Used by controller – not related to the LED.

- Info or Warning type faults–Amber lamp: 0x04
- Critical or severe type faults–Red lamp: 0x10

Occurrence counter

Number of times the active fault has appear previously.

Fault information of the Fault 1 and 3

- Bits 24 to 6: SPN of active fault
- Bits 5 to 1: FMI if active fault

Fault information of the Fault 2

- Bits 16 to 6: SPN of active fault
- Bits 5 to 1: FMI if active fault

Diagnostic Message 3 (DM3)

The Clear previous active trouble code name **Diagnostic Message 3 (DM3)** is used by the controller to clear the error log within the PVE-CI.

PGN	0x18EA00
Transmission timing rate	On request

DM3 frame format

Msg ID	DLC	Byte 1	Byte 2	Byte 3
18EAxxxx	3	0xCC	0xFE	0x00

Changing Node ID

The Node ID parameter can be programmed by using:

ISOBUS/J1939 Communication Protocol

- The Service Tool.
- Commanded address according to ISOBUS/J1939.

Commanded address according to ISOBUS/J1939

Frame format

Msg ID	DLC	Byte 1	Byte 2	Byte 3	Byte 4	Byte 5
0x1BC7888x	5	0x04	0x2E	0x10	0x01	Node ID

Node ID data

Byte 1	Fixed
Byte 2	Fixed
Byte 3	Fixed
Byte 4	Fixed
Byte 5	Node ID Range: 0x80 to 0x8F

Example of changing Node ID from 0x83 to 0x86

Msg ID	DLC	Byte 1	Byte 2	Byte 3	Byte 4	Byte 5
Application controller						
0x1BC78883	5	0x04	0x2E	0x10	0x01	0x86

Example of response from the PVE when changing the Node ID

Msg ID	DLC	Byte 1	Byte 2	Byte 3	Byte 4
Positive response (same for all nodes)					
0x1BC408F1	4	0x03	0x6E	0x10	0x01
Negative response					
0x1BC408F1	4	0x03	0x7F	0x2E	0x31

PVE-CI Address claim

Before a device can participate in sending CAN messages on a network, claim its address. The PVE-CI transmits its device address together with the device name to the network at boot-up.

The Address Claim message contains the following information

Msg ID	DLC	Byte 1	Byte 2	Byte 3		Byte 4
0x18EEFFyy*	8	Identity Number (LSB)	Identity Number (2nd byte)	Manufacturer Code (3 LSB)	Identity Number (5 MSB)	Manufacturer Code (MSB)
NAME						

*yy is the Source address = Node ID (80-8F)

Byte 5		Byte 6	Byte 7		Byte 8		
Function Instance (5 bits)	ECU Instance (3 bits)	Function (8 bits)	Vehicle System (7 bits)	Reserved (1 bits)	Arbitrary Address Capable (1 bit)	Industry Group (3 bits)	Vehicle System Instance (4 bits)
NAME							

ISOBUS/J1939 Communication Protocol

Address claim request

The Address claim message can be requested by the master using a request PGN

0x00EE00

Transmission rate: On request.

Frame Format for Request PGN message

Msg ID	DLC	Byte 1	Byte 2	Byte 3
0x18EAxxxx (Request PGN)	3	Requested PGN (LSB)	Requested PGN (MSB)	0x00
		0x00	0xEE	

Response: On sending the address claim request the PVE-CI sends address claim message.

Both specific and global requests for address claim are supported.

Commanded address (ISOBUS/J1939)

Commanded address is used to Change the Node ID of the valve by using the “Name field” broadcasted in the address claim message. This commanded address request is sent via a BAM once the commanded address is matched and the Node ID is valid. This will make the valve reset and announce itself with the new Node ID.

Only a sub-set of J1939-81 is supported.

The three supported capabilities according to J1939-81, Appendix B are:

- Support Commanded Address
- Address Configuration Capability
- Name Retained Across Power-up Cycles

Frame format

PGN	DLC	Byte 1	Byte 2	Byte 3	Byte 4	Byte 5	Byte 6	Byte 7	Byte 8
0xFED8		NAME							Node ID

Node ID data

DLC	
Byte 1	Name (see address claim)
Byte 2	
Byte 3	
Byte 4	
Byte 5	
Byte 6	
Byte 7	
Byte 8	Node ID Range: 0x80 to 0x8F

Example of changing Node ID in the PVEA-CI with name “01 00 20 07 08 FF 02 20” to Node ID 0x81:

	Msg ID	DLC	Byte 1	Byte 2	Byte 3	Byte 4	Byte 5	Byte 6	Byte 7	Byte 8
BAM	0x1CECFx	8	0x20	0x09	0x00	0x02	0xFF	0xD8	0xFE	0x00
			BAM	No of bytes	No of bytes	No of packets	Reserved	PGN (0x00FED8)		
DT1	0x1CEBFx	8	0x01	0x01	0x00	0x20	0x07	0x08	0xFF	0x02
			Seq.	NAME						

ISOBUS/J1939 Communication Protocol

	Msg ID	DLC	Byte 1	Byte 2	Byte 3	Byte 4	Byte 5	Byte 6	Byte 7	Byte 8
DT2	0x1CEBFxx	8	0x02	0x20	0x81	0xFF	0xFF	0xFF	0xFF	0xFF
			Seq	NAME	New applicati on Node ID (0x81)					

ISOBUS/J1939 error codes

Error codes

Priority	Error	J1939 DTC	Source of Fault	Lamp Status	Regulation
1	Spool not at set point	0x878FEC	External	Critical	Active
2	Spool cannot reach float	0x878FEE	External	Critical	Active
3	Internal Error	0x8B8FFA	Internal	Severe	Active
4	CAN bus Error	0x938FD7	External	Warning	Active
5	Temperature Error	0x908FF1	External	Warning	Shut Down
6	Power supply exceeds specification	0x030273	External	Warning	Shut Down
7	Power supply is below specification	0x040273	External	Warning	Shut Down
8	Time guarding error	0x938FE9	External	Warning	Active

CANopen Communication Protocol

The CANopen interface version of PVE-CI is compliant with the following CANopen standards and includes the EDS file with the object dictionary listed below. The EDS file can be found on www.powersolutions.danfoss.com. At the end of this document you will find use cases showing the most common features.

- [Use case 1 - Boot-up to operation mode](#) on page 37
- [Use case 2 - Operation Mode – Error – Operation Mode](#) on page 37
- [Use case 3 - Change Node ID globally](#) on page 38
- [Use case 4 - Change Node ID for specific Node](#) on page 39

The standard supported are:

- CiA 301 version 4.2.0
- CiA 305 version 1.5.2
- CiA 408 version 3.0.0

EDS file object dictionary

1000	Device type
1001	Error register
1003	Predefined error field
1005	COB-ID SYNC
100A	Manufacturer software version
1010	Store parameters
1011	Restore default parameters
1014	COB-ID EMCY
1017	Producer heartbeat time
1018	Identity object
1028	Emergency consumer
1400	RPDO parameter
1600	RPDO mapping
1800	TPDO parameter
1A00	TPDO – profile specific mapping 2
2001	Error: supply voltage too high
2002	Error: supply voltage too low
200F	Error: temperature too high
2019	Error: CAN error
201D	Error: spool not at set-point/float not reached
2023	Error: set-point timeout
2040	Error: internal error
3300	Manufacturer specific set-point - 8 bit
3301	Manufacturer specific actual value - 8 bit
3302	Manufacturer specific actual inverted value - 8 bit
3303	Manufacturer specific set-point - 16 bit
3304	Manufacturer specific actual value - 16 bit
6040	Device control word
6041	Device status word
6042	Device mode
6052	Device serial number
6053	Device description
605F	Device capability

CANopen Communication Protocol

EDS file object dictionary (continued)

6300	v poc_set_point
6301	v poc_actual_value

NMT operations

NMT (communication state machine) operations can drive the device state machine.

The next diagram shows the relationship between the communication state machine and the device state machine.

Device State Machine and Communication State Machine

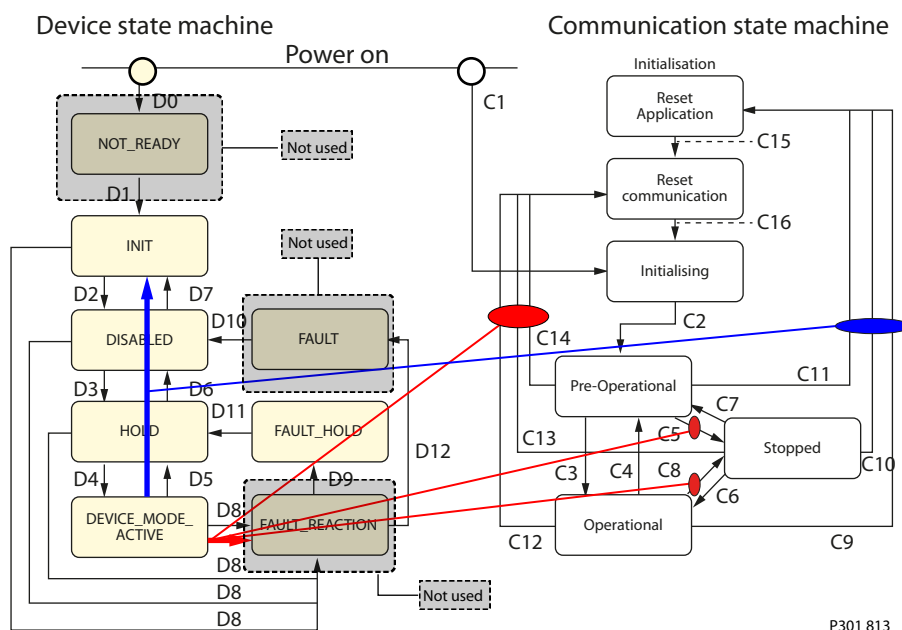

P301 813

Following table summarizes the impact of the Communication State Machine on Device State Machine.

Action in CSM	Transition	Impact on DSM
Reset Communication	C14, C13, C12	Device changes state to fault hold
State change from Preoperational to stopped	C5	Device changes state to fault reaction
State change from operational to Stopped	C8	Device changes state to fault reaction
Reset Application	C9, C10, C11	Device goes to initialization state

The PVE-CI is working according to the device state.

Following table shows the PVE-CI behavior depending on the state

State vs. Function	Set-Point Input	Transmit TPDO	Spool Monitoring	Spool Control	Set-Point Time guarding
NOT_READY	Not Applicable				
INIT	X	YES	NO	NO	NO
DISABLED	X	YES	NO	NO	NO
HOLD	X	YES	NO	NO	NO
DEVICE_MODE_ACTIVE	Full operational	YES	YES	YES	YES
DEVICE_MODE_ACTIVE	Hand operation	YES	NO	NO	NO

CANopen Communication Protocol

State vs. Function	Set-Point Input	Transmit TPDO	Spool Monitoring	Spool Control	Set-Point Time guarding
FAULT	Not Applicable				
FAULT_HOLD	X	YES	NO	NO	NO
FAULT_REACTION	Not Applicable				

The PVE-CI can be initialized by using NMT services, started monitored, reset or stopped. The PVE-CI valve supports following NMT states:

Initialization PVE-CI implements only "Initializing Sub-State". After initialization of communication parameters the state will be pre-operational.

Pre-Operational In NMT state = communication via SDO's are possible.

Operational All the communication objects are active.

Stopped All the communication objects are stopped except heartbeat.

Following table shows the message format for NMT services .

	COB-D	DLC	Byte 0	Byte 1
NMT Command	0x000	2	NMT Command	Destination Node ID

[If a global message needs to be sent then use 0x00 as destination Node ID](#)

[The NMT service has direct impact on the device state machine \(see *Device State Machine and Communication State Machine* on page 17\).](#)

Boot-up protocol

Upon power-up the PVED will log onto the CAN bus network by broadcasting the nodeID it has been given upon parametrization.

Frame format

Msg ID	DLC	Byte 0
0x700 + nodeID	1	NMT State
		0x00

NMT services supported

Start remote Node

The NMT master uses this service to start the remote node. The new NMT state is operational.

Start remote Node

COB-ID	DLC	Byte 0	Byte 1
0x000	2	NMT Command Specifier	0x01
		Slave Node ID*	

* All = 0, 1 Slave = COB-ID

[This service is unconfirmed. Here after the PVE-CI goes in operational mode and accepts the Rx PDO's.](#)

Stop remote device

The NMT master uses this service to stop the remote device. Once the device is stopped it does not accept the Rx PDO's.

CANopen Communication Protocol

Stop remote Node

COB-ID	DLC	Byte 0	Byte 1
0x000	2	NMT Command Specifier	Slave Node ID
		0x02	

This service is unconfirmed.

Enter pre-operational

The NMT master uses this service to enter pre-operational state.

Enter pre-operational

COB-ID	DLC	Byte 0	Byte 1
0x000	2	NMT Command Specifier	Slave Node ID
		0x80	

Reset application

The NMT master uses this service to perform a software reset.

Reset application

COB-ID	DLC	Byte 0	Byte 1
0x000	2	NMT Command Specifier	Slave Node ID
		0x81	

Reset communication

The NMT master uses this service to reset the communication state machine. The entire CANopen library is reset and reinitialized on receiving reset communication command.

Reset communication

COB-ID	DLC	Byte 0	Byte 1
0x000	2	NMT Command specifier	Slave Node ID
		0x82	

State feedback values

Identifier example - frame

COB-ID	DLC	Byte 0	Byte 1	Byte 2	Byte 3
0x180 + Node ID	4	Current state	0x00	Spool position*	Spool position*

* spool position value = ± 16384 (float=32767)

Identifier example - INIT state

COB-ID	DLC	Byte 0	Byte 1	Byte 2	Byte 3
0x180 + Node ID	4	0x08	0x00	Spool position	Spool position

Identifier example - Disabled

COB-ID	DLC	Byte 0	Byte 1	Byte 2	Byte 3
0x180 + Node ID	4	0x09	0x00	Spool position	Spool position

CANopen Communication Protocol

Identifier example – Hold

COB-ID	DLC	Byte 0	Byte 1	Byte 2	Byte 3
0x180 + Node ID	4	0x0B	0x00	Spool position	Spool position

Identifier Example - Active

COB-ID	DLC	Byte 0	Byte 1	Byte 2	Byte 3
0x180 + Node ID	4	0x0F	0x00	Spool position	Spool position

Identifier example – Fault hold

COB-ID	DLC	Byte 0	Byte 1	Byte 2	Byte 3
0x180 + Node ID	4	0x03	0x00	Spool position	Spool position

Device control word

The device takes following transitions on writing device control word.

Transition Number *	Transition	Device Control Command	RMHD** (x = don't care)
D2	INIT to DISABLED	Activate DISABLED	xxx1
D3	DISABLED TO HOLD	Activate HOLD	xx11
D4	HOLD TO ACTIVE	Activate ACTIVE	x111
D5	ACTIVE TO HOLD	Deactivate Active	x0xx
D6	HOLD TO DISABLED	Deactivate Hold	x00x
D7	DISABLED TO INIT	Deactivate Disabled	x000
D11	FAULT HOLD TO HOLD	Reset Fault Hold	0011 → 1011

* See [Device State Machine and Communication State Machine](#) on page 17

** R: Status word ready (bit 3), M: Status word device mode active enable (Bit 2), H: Status word Hold activated (Bit 2), Status word disabled (Bit 0)

LSS slave

The PVE-CI Series CiA 305 3.0.0 support the LSS slave functionality.

[All LSS commands to be sent by Standard COB-ID: 0x7E5. Will respond with the standard feedback message COB-ID: 0x7E4](#)

PVE-CI switch state global

[Only one CANopen slave can be connected to the bus while changing the Node ID globally.](#)

This command sets the device to LSS configuration mode. This is unconfirmed service.

LSS Cmd

COB-D	DLC	Byte 0	Byte 1	Byte 2	Byte 3	Byte 4	Byte 5	Byte 6	Byte 7
0x7E5	8	CS	Mode	Reserved					
		0x04	XX	0x00	0x00	0x00	0x00	0x00	0x00

CANopen Communication Protocol

LSS modes

Value	Mode description
0x00	Switch to LSS wait state
0x01	Switch to LSS configuration state
0x02	Reserved

PVE-CI switch state selective

LSS master device switches the LSS slave device into LSS configuration state, whose LSS address is equal to the one that is specified in the command.

LSS Cmd

COB-ID	DLC	Byte 0	Byte 1	Byte 2	Byte 3	Byte 4	Byte 5	Byte 6	Byte 7	
0x7E5	8	CS	Vendor ID				Reserved			
		0x40	LSB	XX	XX	MSB	0x00	0x00	0x00	

LSS Cmd

COB-ID	DLC	Byte 0	Byte 1	Byte 2	Byte 3	Byte 4	Byte 5	Byte 6	Byte 7	
0x7E5	8	CS	Product Code				Reserved			
		0x41	LSB	XX	XX	MSB	0x00	0x00	0x00	

LSS Cmd

COB-ID	DLC	Byte 0	Byte 1	Byte 2	Byte 3	Byte 4	Byte 5	Byte 6	Byte 7	
0x7E5	8	CS	Revision Number				Reserved			
		0x42	LSB	XX	XX	MSB	0x00	0x00	0x00	

LSS Cmd

COB-ID	DLC	Byte 0	Byte 1	Byte 2	Byte 3	Byte 4	Byte 5	Byte 6	Byte 7	
0x7E5	8	CS	Serial Number				Reserved			
		0x43	LSB	XX	XX	MSB	0x00	0x00	0x00	

The device will respond with the message below when it has entered configuration mode.

Response

COB-ID	DLC	Byte 0	Byte 1	Byte 2	Byte 3	Byte 4	Byte 5	Byte 6	Byte 7
0x7E4	8	CS	Reserved						
		0x44	0x00	0x00	0x00	0x00	0x00	0x00	0x00

Follow the below sequence of LSS commands to send a PVE-CI into configuration mode (See [Use case 4 - Change Node ID for specific Node](#) on page 39 for an example)

COB-ID	DLC	CS and Data	Comments
0x7E5	8	40 19 00 00 01 00 00 00	LSS Address – Vendor ID [OD Index 0x1018 Sub index 0x01]
0x7E5	8	41 00 00 36 53 00 00 00	LSS Address – Product Code [OD Index 0x1018 Sub index 0x02]
0x7E5	8	42 30 01 00 00 00 00 00	LSS Address – Revision Number [OD Index 0x1018 Sub index 0x03]

CANopen Communication Protocol

COB-ID	DLC	CS and Data	Comments
0x7E5	8	43 xx xx xx xx 00 00 00	LSS Address – Serial Number [OD Index 0x1018 Sub index 0x04]
0x7E4	8	44 00 00 00 00 00 00 00	Response [Device has entered into configuration mode]

Configure Node ID

LSS slave is configured to a new Node ID provided in the command below. The PVE-CI confirms the success or failure of the service. (Configure new Node ID [Use case 3 - Change Node ID globally](#) on page 38).

LSS Cmd

COB-ID	DLC	Byte 0	Byte 1	Byte 2	Byte 3	Byte 4	Byte 5	Byte 6	Byte 7
0x7E5	8	CS	Node ID	Reserved					
		0x11	XX	0x00	0x00	0x00	0x00	0x00	0x00

Node ID: Valid Node ID in range 0x01 – 0x7F.

Response to service:

Response

COB-ID	DLC	Byte 0	Byte 1	Byte 2	Byte 3	Byte 4	Byte 5	Byte 6	Byte 7
0x7E4	8	CS	Error Code	Reserved					
		0x11	XX	0x00	0x00	0x00	0x00	0x00	0x00

Error Code	Description
0x00	No Error
0x01	Node ID out of range
0x02 – 0xFF	Reserved

Configure bit timing parameters

LSS slave is configured to the new bit rate provided in the command below. The PVE-CI confirms the success or failure of the service.

LSS Cmd

COB-ID	DLC	Byte 0	1	Byte 2	Byte 3	Byte 4	Byte 5	Byte 6	Byte 7
0x7E5	8	CS	Table Selector	Table Index	Reserved				
		0x13	XX	0x00	0x00	0x00	0x00	0x00	0x00

For bit timing Table Selector '0x00' should be used. The PVE-CI supports following bit rates:

Table Index	Bit Rate
2	500 kbps
3	250 kbps
4	125 kbps

Response to the service:

CANopen Communication Protocol

Response

COB-ID	DLC	Byte 0	Byte 1	Byte 2	Byte 3	Byte 4	Byte 5	Byte 6	Byte 7
0x7E4	8	CS	Error Code	Reserved					
		0x13	XX	0x00	0x00	0x00	0x00	0x00	0x00

Error Code	Meaning
0x00	No Error
0x01	Bit rate not supported
0x02 – 0xFF	Reserved

Activate bit timing parameters

This service activates simultaneously the bit rate at the LSS communication interface of all CANopen devices in the network.

LSS Cmd

COB-ID	DLC	Byte 0	Byte 1	Byte 2	Byte 3	Byte 4	Byte 5	Byte 6	Byte 7
0x7E5	8	CS	Switch Delay		Reserved				
		0x15	LSB	MSB	0x00	0x00	0x00	0x00	0x00

Each LSS slave device copies the pending bit rate to the active bit rate value, after 'Switch Delay' (given in ms, in multiples of 1 ms) has elapsed. Therefore in response to this service device changes its bit rate after 'Switch Delay'.

PVE-CI store configurations

LSS master device requests the LSS slave device to store the configured local layer settings to EEPROM with this service. Configured local layer settings include configured new Node ID and new Bit Rate. The PVE-CI confirms the success or failure of the service.

LSS Cmd

COB-ID	DLC	Byte 0	Byte 1	Byte 2	Byte 3	Byte 4	Byte 5	Byte 6	Byte 7
0x7E5	8	CS	Reserved						
		0x17	0x00	0x00	0x00	0x00	0x00	0x00	0x00

Response to service:

Response

COB-ID	DLC	Byte 0	Byte 1	Byte 2	Byte 3	Byte 4	Byte 5	Byte 6	Byte 7
0x7E4	8	CS	Error Code	Reserved					
		0x17	XX	0x00	0x00	0x00	0x00	0x00	0x00

Error Code	Meaning
0x00	No Error
0x01	Storage configuration not supported
0x02	Storage media access error
0x03 – 0xFF	Reserved

CANopen Communication Protocol

PVE-CI identify non-configured remote slave

LSS slave devices to identify themselves by means of the 'LSS identify non-configured slave' service, who got stuck in NMT Initialization state and who have no active node-ID.

The service is unconfirmed.

LSS Cmd

COB-ID	DLC	Byte 0	Byte 1	Byte 2	Byte 3	Byte 4	Byte 5	Byte 6	Byte 7
0x7E5	8	CS	Reserved						
		0x4C	0x00	0x00	0x00	0x00	0x00	0x00	0x00

Identify non-configured slave

LSS slave device indicates that it is an LSS slave device that got stuck in NMT Initialization state and no active node-ID. This service is executed in case a LSS identify non-configured remote slave service was initiated by the LSS master device. The service is unconfirmed.

Response to Identify Non-Configured Remote Slave service:

Response

COB-ID	DLC	Byte 0	Byte 1	Byte 2	Byte 3	Byte 4	Byte 5	Byte 6	Byte 7
0x7E4	8	CS	Reserved						
		0x50	0x00	0x00	0x00	0x00	0x00	0x00	0x00

Fast scan

By means of this service the LSS master requests all un-configured LSS slaves to identify themselves.

LSS Cmd

COB-ID	DLC	Byte 0	Byte 1	Byte 2	Byte 3	Byte 4	Byte 5	Byte 6	Byte 7	
0x7E5	8	CS	ID Number				Bit Chek	LSS Sub	LSS Next	
		0x51	XX	XX	XX	XX	XX	XX	XX	

For information on bit fields refer to 'CiA CANopen: Layer setting service and protocol'.

Specified sequence of commands for fast scan

CAN ID	DLC	CS and Data	Comments
0x7E5	8	51 19 00 00 01 00 00 01	Fast scan Vendor ID [OD Index 0x1018 Sub index 0x01]
0x7E5	8	51 00 00 36 53 00 01 02	Fast scan Product Code [OD Index 0x1018 Sub index 0x02]
0x7E5	8	51 30 01 00 00 00 02 03	Fast scan Revision Number [OD Index 0x1018 Sub index 0x03]
0x7E5	8	51 xx xx xx xx 00 03 04	Fast scan Serial Number [OD Index 0x1018 Sub index 0x04]

State behavior

Following table specifies the service supported for the various LSS states.

LSS Service	LSS Waiting	LSS Configuration
Switch State Global	Yes	Yes
Switch State Selective	Yes	No
Configure Node ID	No	Yes
Configure Bit Timing Parameter	No	Yes

CANopen Communication Protocol

LSS Service	LSS Waiting	LSS Configuration
Activate Bit Timing Parameter	No	Yes
Store Configuration	No	Yes
Identify Non-Configured Remote Slave	No	Yes
Identify Non-Configured Slave	No	Yes
Fast Scan	No	Yes

PVE-CI heartbeat protocol

PVE-CI supports the heartbeat protocol for error control services. The heartbeat mechanism can be established by configuring the PVE-CI as a heartbeat producer, and the object dictionary entry **Producer heartbeat time**.

The value denotes the cyclic time at which the heartbeat is produced in ms.

- If the value of the object dictionary entry is 0, the heartbeat message is not sent.
- If the value is different from zero then the heartbeat message is transmitted cyclically.

The resolution of the heartbeat message is 10 ms and is configured at 1000 ms.

Heartbeat period

COB-ID	DLC	Byte 0	Byte 1	Byte 2	Byte 3	Byte 4	Byte 5	Byte 6	Byte 7
0x600+Node ID	8	0x2B	0x17	0x10	0x00	0x64	0x00	0x00	0x00

Heartbeat message

COB-ID	DLC	Byte 0
0x700 + Node ID	1	State

Boot-up message is transmitted cyclically with communication state in byte 0. Following are the possible values of state in the boot-up message.

Boot-up message state values

Boot-up	Stopped	Operational	Preoperational
0x00	0x04	0x05	0x7F

Fault handling

On occurrence of a fault PVE-CI emits an EMCY message. The emergency message contains information on error code, error register and occurrence counters.

EMCY message

COB-ID	DLC	Byte 0	Byte 1	Byte 2	Byte 3	Byte 4	Byte 5	Byte 6	Byte 7
0x80 + Node ID	8	Error code (LSB)	Error code (MSB)	Error register	Error occurrence counter	0x00	0x00	0x00	0x00

The fault is then written to Error history (Predefined error field OD entry: 0x1003). The most recent index is written to first index. The PVE-CI maintains 8 entries of error history.

A Reset EMCY message is transmitted on deactivation of all the errors in the system. The PVE-CI transmits also a reset of EMCY during Boot-up.

CANopen Communication Protocol

Reset EMCY message

COB-ID	DLC	Byte 0	Byte 1	Byte 2	Byte 3	Byte 4	Byte 5	Byte 6	Byte 7
0x80 + Node ID	8	0x00	0x00	0x00	0x00	0x00	0x00	0x00	0x00

The PVE-CI enters FAULT HOLD MODE on activation of active fault. To leave FAULT HOLD MODE, reset fault command should be given (see [Use case 2 - Operation Mode – Error – Operation Mode](#) on page 37). The device leaves FAULT HOLD only if there is no error in the system

PDO mapping procedure

Following is a recommended procedure for the mapping of a PDO:

1. Disable the PDO by setting the valid bit to 1 of sub index 1, RPDO parameter (OD 0x1400)
2. Disable RPDO mapping by setting the sub index (number of entries) 0x00 to 00
3. Set the sub index (number of entries) to number of intended mapped objects
4. Modify the mapping by changing the values of corresponding indexes
5. Create the RPDO by setting valid bit to 0 of sub index 1, RPDO parameter (OD 0x1400)

Object dictionary - communication profile

Device type

Object dictionary entry: 0x1000.

This object provides information on device type and its functionality. PVE-CI responds with value 0x198 indicating that DS408 profile is implemented.

Error register

Object dictionary entry: 0x1001.

This object provides a bitmap of the type of errors present in the system. It is also a part of the EMCY object.

Following table shows the bitmap of error register in PVE-CI.

Type	Bit7	Bit6	Bit5	Bit4	Bit3	Bit2	Bit1	Bit0
Error	Manufactur- er specific	Reserved	Device profile specific	Com	Tempe- rature	Voltage	Current	Generic Error
Spool not at set point			x					x
Spool cannot reach float			x					x
Internal Error								x
CAN bus Error				x				x
Temperature Error					x			x
Power supply exceeds specification						x		x
Power supply is below specification						x		x
Time guarding error	x			x				

Predefined error field

Object dictionary entry: 0x1003.

CANopen Communication Protocol

Sub Index: 1 to 8. Predefined error field maintains the “Error History” of the errors the PVE-CI supports 8 level deep error history:

- On occurrence of any new error, it is written at sub-index 1 in the history.
- If the entire history is filled, the array is overwritten with new errors.
- If no error has occurred in the system, then read access produces an ABORT message.
- Sub-index 0 contains number of actual errors that are recorded.
- Writing 0x00 to sub-index 0 deletes the entire error history.

Field is of following format.

Bits 16-31	Bits 0-15
Error Occurrence counter	Error Code

COB-ID SYNC

Object dictionary entry: 0x1005.

This object indicates the message ID of the sync message that is received by the library. This COB-ID can be changed dynamically during runtime via SDO write. A new CAN filter is then configured and the sync message is accepted by new message ID.

Manufacturer software version

Object dictionary entry: 0x100A.

PVE-CI responds with following string:

APP-_S6m1_M_Rxxx_CANOPEN-_111yyyyy_-rrr_ zzzzzz

Where

xxx is version number.

yyyyy is part number.

zzzzz is Firmware date.

Store parameters

Object dictionary entry: 0x1010.

Sub Index: 0x01.

On writing 0x65766173 to this object, PVE-CI stores values of following parameters from process image to non-volatile memory (EEPROM).

Object	Index	Sub Index
COB-ID Sync	0x1005	-
Producer heartbeat time	0x1017	-
EMCY consumer	0x1028	0x01
RPDO COB-ID	0x1400	0x01
RPDO transmission type	0x1400	0x02
RPDO number of entries	0x1600	0x00
1st application object – device control word	0x1600	0x01
2nd application object – set-point	0x1600	0x02
3rd application object – dummy	0x1600	0x03
4th application object – dummy	0x1600	0x04
5th application object – dummy	0x1600	0x05
6th application object – dummy	0x1600	0x06

CANopen Communication Protocol

Object	Index	Sub Index
7th application object – dummy	0x1600	0x07
8th application object – dummy	0x1600	0x08
TPDO COB-ID	0x1800	0x01
TPDO – transmission type	0x1800	0x02
TPDO number of entries	0x1A00	0x00
1st application object – device status word	0x1A00	0x01
2nd application object – set-point	0x1A00	0x02
3rd application object – dummy	0x1A00	0x03
4th application object – dummy	0x1A00	0x04
5th application object – dummy	0x1A00	0x05
6th application object – dummy	0x1A00	0x06
7th application object – dummy	0x1A00	0x07
8th application object – dummy	0x1A00	0x08
Device description	0x6053	-

Wait ≥ 500ms before software reset.

Restore default parameters

Object dictionary entry: 0x1011.

PVE-CI supports the object “restore default parameters”.

Sub Index: 0x01

Upon writing value 0x64616F6C to sub Index 0x01, PVE-CI prepares itself to restore the default parameters on next boot-up.

Following are the default values of parameters.

Parameter	Default value
COB-ID Sync	0x80
Producer heartbeat time	0x00
EMCY consumer	0x80000000
RPDO COB-ID	\$NODE_ID+0x00000200
RPDO Transmission type	0xFF
RPDO Number of entries	0x02
RPDO mapping parameter 1	0x60400010
RPDO mapping parameter 2	0x63000110
RPDO mapping parameter 3	0x00010001
RPDO mapping parameter 4	0x00010001
RPDO mapping parameter 5	0x00010001
RPDO mapping parameter 6	0x00010001
RPDO mapping parameter 7	0x00010001
RPDO mapping parameter 8	0x00010001
TPDO COB-ID	\$NODE_ID+0x00000180
TPDO Transmission type	0xFF
TPDO Number of entries	0x02
TPDO mapping parameter 1	0x60410010
TPDO mapping parameter 2	0x63010110
TPDO mapping parameter 3	0x00010001

CANopen Communication Protocol

Parameter	Default value
TPDO mapping parameter 4	0x00010001
TPDO mapping parameter 5	0x00010001
TPDO mapping parameter 6	0x00010001
TPDO mapping parameter 7	0x00010001
TPDO mapping parameter 8	0x00010001
Device Description	PVEA-CI S6 / PVEO-CI S6

Sub Index: 0x05

Writing value 0x73646B70 to Sub-Index 0x05 clears all the error occurrence counters.

[Clearing of Error occurrence counters takes at least 50 ms.](#)

COB-ID EMCY

Object dictionary entry: 0x1014.

This object is read only object and represents the COB-ID of EMCY message.

The value is Node ID + 0x80.

Producer heartbeat time

Object dictionary entry: 0x1017.

This object holds the value of heartbeat producer in ms when a non-zero value is written to this object the PVE-CI valve starts producing the heartbeat message with frequency equal to this value in ms.

[Minimum resolution is 10 ms.](#)

Identity object

Object dictionary entry: 0x1018.

The identity object provides general information of the PVE-CI. The following sub-indexes are implemented:

- Sub-index 0: Highest sub-index supported. This value is 3.
- Sub-index 1: Vendor ID. This value is 0x0100 0019.
- Sub-index 2: Product code: This value is 0x5336 0000.
- Sub-index 3: Revision number: This value is a binary coded decimal encoded software version number (i.e. version R1.31 becomes 0x0001 001F).

PVE-CI emergency consumer

Object dictionary entry: 0x1028.

PVE-CI uses the EMCY consumer as emergency stop message. The PVE -CI enters into fault state if:

- the valve is in active state (TR8)
- an error code of 0x1000 is received

The error message will be ignored if the above listed conditions are not fulfilled.

The Sub Entry at index 0x01 represents COB-ID of emergency consumer. This is kept as 0x80000000 by default, which means disabled. This COB-ID must be configured before sending emergency consumer.

RPDO parameter

Object dictionary entry: 0x1400.

This parameter is used to describe the RPDO. It describes the COB-ID of RPDO and transmission type.

If Transmission type is fixed at 0xFF.

CANopen Communication Protocol

To change COB-ID one has to disable the PDO before writing a new value.

RPDO mapping

Object dictionary entry: 0x1600.

RPDO is mapped to device control word and Set point by default (Default parameter setting). The parameter value is stored and read from EEPROM during boot-up.

Following parameters can be mapped:

1. 6040,00 Device control word
2. 3300,00 Manufacturer specific set-point – 8bit
3. 3303,00 Manufacturer specific set-point – 16bit
4. 6042,00 Device mode
5. 6300,01 vpoc_set_point_value

TPDO parameter

Object dictionary entry: 0x1800.

This parameter is used to describe the TPDO. It describes the COB-ID used by TPDO and transmission type:

- If transmission type is 0xFF = the transmission event is driven and one TPDO is transmitted for every RPDO.
- If transmission type is set to 0x01-0xF0 = the transmission of TPDO is event driven (cyclic every Nth sync). Other values are unsupported.

You need to disable the PDO before changing the COB-ID.

TPDO mapping

Object dictionary entry: 0x1A00.

TPDO is mapped to Device status word and VPOC actual value by default (Default parameter setting). The parameter value is stored and read from EEPROM during boot-up.

Following parameters can be mapped:

1. 3301,00 Manufacturer specific actual value
2. 3302,00 Manufacturer specific actual inverted value
3. 3304,00 Device status word
4. 6301,00 Vpoc_actual_value

Object dictionary

Standardized device profile

Device control word

Object dictionary entry: 0x6040.

This Entry holds the value of device control word the 7 difference transitions are listed below. The control word controls the device state machine.

PVE-CI performs the following transitions on writing device control word

Transition Number	Transition	Device Control Command	RMHD
D 2	INIT to DISABLED	Activate DISABLED	xxx1
D 3	DISABLED TO HOLD	Activate HOLD	xx11
D 4	HOLD TO ACTIVE	Activate ACTIVE	x111

CANopen Communication Protocol

PVE-CI performs the following transitions on writing device control word (continued)

Transition Number	Transition	Device Control Command	RMHD
D 5	ACTIVE TO HOLD	Deactivate Active	x0xx
D 6	HOLD TO DISABLED	Deactivate Hold	x00x
D 7	DISABLED TO INIT	Deactivate Disabled	x000
D 11	FAULT HOLD TO HOLD	Reset Fault Hold	1011

Device status word

Object dictionary entry: 0x6041.

This object represents the state of device state machine. Following tables shows the states and representation in status word.

Device State	RMHD* representation	Conditions
INIT	1000	Initializations successful, device function disabled, communication enabled
DISABLED	1001	Device function disabled
HOLD	1011	Valve in factory mode, device function disabled
ACTIVE	1111	Solenoids active
FAULT HOLD	0011	Active error is present in the system, solenoids disabled

* R: Status word ready (bit 3), M: Status word device mode active enable (Bit 2), H: Status word Hold activated (Bit 2), Status word disabled (Bit 0)

Object name	Object dictionary entry	Object description	Comment
Device mode	0x6042	0X01 = Full operational 0x02 = Hand operation	The object is guarded for any other values than these.
Device Serial Number	0x6052	Visible string read from the EEPROM	
Device Description	0x6053	Displays string (PVEA-CI S6 / PVEO-CI S6) depending on variant type	Write up to 10 characters
Device Capability	0x605F	Capabilities of the PVEA-CI S6 The value of this object is 0x0500 0000	Hydraulic proportional valve with closed loop spool position monitoring
Vpoc_set_point	0x6300	Actual set point position range of -16384 (-100%) to 16384 (100%)	A value of 32767 represents float
Vpoc_actual_value	0x6301	Actual spool position scaled in range of -16384 (-100%) to 16384 (100%)	A value of 32767 represents float

Manufacturer specific

	Object dictionary entry	Object description	Emergency error code	Error register	Maximum occurrence counter
Error - Supply Voltage Too High	0x2001	Error: supply voltage too high	0x3411	0x05	0x7F
Error - Supply Voltage Too Low	0x2002	Error: supply voltage too low	0x3412	0x05	0x7F
Error - Temperature Too High	0x200F	Error: temperature crosses boundaries of -40 °C to 120 °C	0x8301	0x09	0x7F

CANopen Communication Protocol

	Object dictionary entry	Object description	Emergency error code	Error register	Maximum occurrence counter
Error - CAN Error	0x2019	Error on the CAN bus	0x8140	0x11	0x7F
Error - Spool not at Set-point / Float Not Reached	0x201D	Spool position error	0x8305	0x21	0x7F
Error - Set-point Timeout	0x2023	Spool position not reached within timeout	0x8003	0x91	0x7F
Error - Internal Error	0x2024	Internal error	0x1000	0x01	0x7F

Unified Diagnostic Services (UDS) lite

The UDS protocol is supported by application for following services:

1. Read Data by Identifier
2. Write data by Identifier

UDS - message ID formation

UDS message ID's are formed as shown below.

Request message ID

Following table shows message ID formation for message to node ID 0x05 on net 0 from node 0xF1.

29 Bit CAN Identifier										
Priority			Extended Data Page	Data Page	Type of Service (TOS)		Source Address		Destination Address	
28	27	26			23	22	Net	Node	Net	Node
1	1	0	1	1	1	1	000	11110001	000	00000101
0x1BC028F1										

Response message ID

Following table shows a response message from node 0x05 to 0xF1.

29 Bit CAN Identifier										
Priority			Extended Data Page	Data Page	Type of Service (TOS)		Source Address		Destination Address	
28	27	26			23	22	Net	Node	Net	Node
1	1	0	1	1	1	1	000	00000101	000	11110001
0x1BC028F1										

UDS – read data by identifier

The PVE-CI supports the read data by identifier command. This service is used for reading out ECU data from a node. Some identifiers are predefined in the standard and some are specific for the ECU.

Service ID: 0x22.

Service request

Msg ID	DLC	Byte 0	Byte 1	Byte 2	Byte 3
UDS Request Message ID	0x04	0x03	0x22	ID	

CANopen Communication Protocol

Positive response

Msg ID	DLC	Byte 0	Byte 1	Byte 2	Byte 3	Byte 4 - Byte 7
UDS Response Message ID	xx	Number of bytes to follow in frame	0x62	ID		Data

Negative response

Msg ID	DLC	Byte 0	Byte 1	Byte 2	Byte 3
UDS Response Message ID	4	3	0x7F	0x22	Error Code

Error codes

Error Code	Error Message	Error Cause
0x13	Incorrect Message Length	Length of the request message is incorrect
0x22	Conditions not correct	Operating conditions of the server are not met
0x31	Request Out of Range	Read Identifier not supported by ECU

UDS – write data by identifier

PVE-CI supports write data by identifier command. This service writes data to a particular node of ECU.

Service ID: 0x2E.

Service request – Data Bytes 1

Msg ID	DLC	Byte 0	Byte 1	Byte 2	Byte 3	Byte 4
UDS Request Message ID	0x05	0x04	0x2E	ID		Data

Service request – Data Bytes 2

Msg ID	DLC	Byte 0	Byte 1	Byte 2	Byte 3	Byte 4	Byte 5
UDS Request Message ID	0x06	0x05	0x2E	ID		Data	Data

Service request – Data Bytes 3

Msg ID	DLC	Byte 0	Byte 1	Byte 2	Byte 3	Byte 4	Byte 5	Byte 6
UDS Request Message ID	0x07	0x06	0x2E	ID		Data	Data	Data

Service request – Data Bytes 4

Msg ID	DLC	Byte 0	Byte 1	Byte 2	Byte 3	Byte 4 - Byte 7
UDS Request Message ID	0x08	0x07	0x2E	ID		Data

Positive response

Msg ID	DLC	Byte 0	Byte 1	Byte 2	Byte 3
UDS Response Message ID	4	5	0x6E	ID	

CANopen Communication Protocol

Negative response

Msg ID	DLC	Byte 0	Byte 1	Byte 2	Byte 3
UDS Response message ID	4	3	0x7F	0x2E	Error Code

Error code

Error Code	Error Message	Error Cause
0x13	Incorrect Message Length	Length of the message is wrong, DLC and PCI do not match
0x22	Conditions not correct	Operating conditions of the server are not met
0x31	Request Out of Range	Data Identifier not supported by ECU / Address out of range
0x33	Security Access Denied	Server is not in unlocked state, Valve not in factory mode
0x72	Programming failure	Cannot write to memory

UDS – change Node ID

Node ID can be changed with Identifier 0x1001.

Sub-function Identifier	Name	Access	Value/Range	Default	Description
0x 1001	Node ID	R/W	0x01-0x7F	0x20	The boot loader uses the Node ID value directly. Node ID a restart of the PVE-CI Series 6 is required.

Change of Node ID command

Msg Type	Msg ID	DLC	Byte 0	Byte 1	Byte 2	Byte 3	Byte 4
Change Node ID	UDS request message ID	5	0x03	0x2E	0x01	0x10	Node ID

Example of Change of Node ID Command

Change Node ID from 0x20 to 0x21

Msg Type	Msg ID	DLC	Byte 0	Byte 1	Byte 2	Byte 3	Byte 4
Change Node ID	0x1BC78820	5	0x04	0x2E	0x01	0x10	0x21

PVE replies with

Msg Type	Msg ID	DLC	Byte 1	Byte 2	Byte 3	Byte 4
Change Node ID	0x1BC408F1	4	0x03	0x6E	0x01	0x10

Error messages sent on invalid situations while changing node id

Error Code	Error Message	Error Cause
0x11	Service Not supported	Invalid SID
0x13	Invalid data length	DLC is incorrect
0x31	Request out of range	Node ID is out of valid range
0x72	Programming failure	EEPROM write invalid

CANopen Communication Protocol

Complete example of procedure of changing Node ID

CAN Id	DLC	PCI and Data	Comments
0x1BC78820	5	04 2E 10 01 21	Write Node ID to 0x21
0x1BC408F1	4	03 6E 20 02	Positive response

UDS – ECU identification

PVE-CI supports the read of following ECU parameters for PLUS+1® Service Tool ECU Identification





Sub-function Identifier	Name	Access	Value/Range	Default	Description
0xF010	Address format	R	0xA5	0xA5	Fixed value
0xF1FA 0xF1FB 0xF1FC 0xF1FD	Diagnostic file identifier	R		-	Unique ID to identify the interface of the product
0xF192	ECU Hardware number	R	32bit integer	-	Part number
0xF193	ECU Hardware version	R	Four character alpha numeric string. Left adjusted. Padded with whitespaces	-	
0xF194	ECU Software number	R	32bit integer	-	
0xF195	ECU Software version	R	Four character alpha numeric string. Left adjusted. Padded with whitespaces	-	
0xF18C	ECU Serial number	R	32bit integer	-	
0xF18B	ECU manufacturing date	R	BCD encoded YY,MM,DD	-	

PVEA-CI Series 6 diagnostics

LED Characteristic

The color of the board LED reflects status of the highest priority error in PVE-CI.

LED Characteristic

Color	LED Characteristic	Description
Green constant		No error – Actuating
Green flashing @ 1.5 Hz		Neutral – Power save
Red constant		Internal error
Red flashing @ 1.5 Hz		External or Float error
Yellow		Disable mode

Use cases

Use case 1 - Boot-up to operation mode

The aim with this use case is to go from boot-up message to DEVICE_MODE_ACTIVE, and thereby be able to control the PVE-CI.

Follow the steps below.

1. Power up the PVE-CI

Boot message from PVE-CI:

COB-ID	DLC	Byte 0
0x700 + Node ID*	1	00

* If Node ID = 0x10 then the COB-ID = 0x710

Emergency message: No error from PVE-CI

COB-ID	DLC	Byte 0	Byte 1	Byte 2	Byte 3	Byte 4	Byte 5	Byte 6	Byte 7
0x80 + Node ID	8	00	00	00	00	00	00	00	00

2. Bring the communication state machine (NMT) from Pre-operational to Operational by sending the NMT start command.

COB-ID	DLC	Byte 0	Byte 1
0x00	2	01	*00

* 00 = global message

3. Bring the device state machine (see [Device State Machine and Communication State Machine](#) on page 17) from state INIT to DEVICE_MODE_ACTIVE state by cyclic transmission (100ms) sending the following message:

- First transmission

COB-ID	DLC	Byte 0	Byte 1	Byte 2	Byte 3
0x200+ Node ID	4	0F	00	Set-point	

PVE-CI enters DISABLED state.

- Second transmission

COB-ID	DLC	Byte 0	Byte 1	Byte 2	Byte 3
0x200+ Node ID	4	0F	00	Set-point	

PVE-CI enters HOLD state

- Third transmission

COB-ID	DLC	Byte 0	Byte 1	Byte 2	Byte 3
0x200+ Node ID	4	0F	00	Set-point	

PVE-CI enters DEVICE_MODE_ACTIVE state.

The PVE-CI will now react to set-point sent from the main controller.

Use case 2 - Operation Mode – Error – Operation Mode

The aim with this use case is to get back to DEVICE_MODE_ACTIVE after an error has occurred.

Assuming The PVEA-CI to be in DEVICE_MODE_ACTIVE state and receives set-points from the main controller by cyclic transmission (100ms) sending the following message.

COB-ID	DLC	Byte 0	Byte 1	Byte 2	Byte 3
0x200+ Node ID	4	0F	00	Set-point	

Error: The supply voltage drops under the specified range (11VDC-32VDC).

Use cases

The PVE-CI will respond with the following error message and enter FAULT_HOLD.

COB-ID	DLC	Byte 0	Byte 1	Byte 2	Byte 3
0x80+ Node ID	4	12	34	05	0f*

* numbers of occurrences

Byte 0 and Byte 1 = Emergency error code = 3412 (Manufacturer specific on page 31)

Follow the steps below.

1. Clear the error by ensuring the voltage level to be in the right range.
2. Send the two reset messages.

COB-ID	DLC	Byte 0	Byte 1	Byte 2	Byte 3
0x200+ Node ID	4	03	00	00	00
0x200+ Node ID	4	0B	00	00	00

The PVE-CI will enter DEVICE_MODE_ACTIVE.

Use case 3 - Change Node ID globally

Only one CANopen slave can be connected to the bus while changing the Node ID globally.

Precondition PVE-CI is in stop mode

COB-ID	DLC	Byte 0	Byte 1
0x00	2	0x02	0x00

Follow the steps below.

1. Enter LSS configuration state

COB-ID	DLC	Byte 0	Byte 1	Byte 2	Byte 3	Byte 4	Byte 5	Byte 6	Byte 7
0x7E5	8	04	01	00	00	00	00	00	00

2. Configure Node ID to 0x17.

COB-ID	DLC	Byte 0	Byte 1	Byte 2	Byte 3	Byte 4	Byte 5	Byte 6	Byte 7
0x7E5	8	0x11	0x17	0x00	0x00	0x00	0x00	0x00	0x00

The PVE-CI will respond with

COB-ID	DLC	Byte 0	Byte 1	Byte 2	Byte 3	Byte 4	Byte 5	Byte 6	Byte 7
0x7E4	8	0x11	0x00	0x00	0x00	0x00	0x00	0x00	0x00

3. Store Node ID

COB-ID	DLC	Byte 0	Byte 1	Byte 2	Byte 3	Byte 4	Byte 5	Byte 6	Byte 7
0x7E5	8	0x17	0x00	0x00	0x00	0x00	0x00	0x00	0x00

The PVE-CI will respond with

COB-ID	DLC	Byte 0	Byte 1	Byte 2	Byte 3	Byte 4	Byte 5	Byte 6	Byte 7
0x7E4	8	0x17	0x00	0x00	0x00	0x00	0x00	0x00	0x00

4. Leave LSS configuration state.

COB-ID	DLC	Byte 0	Byte 1	Byte 2	Byte 3	Byte 4	Byte 5	Byte 6	Byte 7
0x7E5	8	0x04	0x00	0x00	0x00	0x00	0x00	0x00	0x00

Use cases

The PVE-CI will respond with

COB-ID	DLC	Byte 0
0x700+ Node ID	1	0x00

Use case 4 - Change Node ID for specific Node

Multiple CANopen slaves can be connected to the bus while changing the specific Node.

For this example

Change Node 0x10 to 0x11 while several devices are connected to the bus.

Precondition – the device must either be in preoperational or operational mode.

Follow the steps below.

1. Read the vendor ID from the identity object using SDO

COB-ID	DLC	Byte 0	Byte 1	Byte 2	Byte 3	Byte 4	Byte 5	Byte 6	Byte 7
0x600 + Node ID	8	0x40	0x18	0x10	0x01	0x00	0x00	0x00	0x00

The PVE will respond with

COB-ID	DLC	Byte 0	Byte 1	Byte 2	Byte 3	Byte 4	Byte 5	Byte 6	Byte 7
0x580 + Node ID	8	0x43	0x18	0x10	0x01	0x19	0x00	0x00	0x01

The last 4 bytes represent the vendor ID: 0x01000019

2. Read the product code from the identity object using SDO

COB-ID	DLC	Byte 0	Byte 1	Byte 2	Byte 3	Byte 4	Byte 5	Byte 6	Byte 7
0x600 + Node ID	8	0x40	0x18	0x10	0x02	0x00	0x00	0x00	0x00

The PVE will respond with

COB-ID	DLC	Byte 0	Byte 1	Byte 2	Byte 3	Byte 4	Byte 5	Byte 6	Byte 7
0x580 + Node ID	8	0x43	0x18	0x10	0x02	0x00	0x00	0x36	0x53

The last 4 bytes represent the product code: 0x53360000

3. Read the revision from the identity object using SDO

COB-ID	DLC	Byte 0	Byte 1	Byte 2	Byte 3	Byte 4	Byte 5	Byte 6	Byte 7
0x600 + Node ID	8	0x40	0x18	0x10	0x03	0x00	0x00	0x00	0x00

The PVE will respond with

COB-ID	DLC	Byte 0	Byte 1	Byte 2	Byte 3	Byte 4	Byte 5	Byte 6	Byte 7
0x580 + Node ID	8	0x43	0x18	0x10	0x03	0x20	0x00	0x01	0x00

The last 4 bytes represent the revision: 0x00010020

4. Read the serial number from the identity object using SDO

COB-ID	DLC	Byte 0	Byte 1	Byte 2	Byte 3	Byte 4	Byte 5	Byte 6	Byte 7
0x600 + Node ID	8	0x40	0x18	0x10	0x04	0x00	0x00	0x00	0x00

Use cases

The PVE will respond with

COB-ID	DLC	Byte 0	Byte 1	Byte 2	Byte 3	Byte 4	Byte 5	Byte 6	Byte 7
0x580 + Node ID	8	0x43	0x18	0x10	0x04	0x00	0x01	0x2E	0x5B

The last 4 bytes represent the serial number: 0x5B2E0100

5. Stop the Node

COB-ID	DLC	Byte 0	Byte 1
0x00	2	0x02	0x10

a) Enter LSS waiting state globally

COB-ID	DLC	Byte 0	Byte 1	Byte 2	Byte 3	Byte 4	Byte 5	Byte 6	Byte 7
0x7E5	8	04	00	00	00	00	00	00	00

LSS switch state selective for the device with the following identification:

- Vendor ID: 0x01000019
- Product code: 0x53360000
- Revisions number: 0x00010020
- Serial number: 0x5B2E0100

6. Write the vendor ID: 0X01000019

COB-ID	DLC	Byte 0	Byte 1	Byte 2	Byte 3	Byte 4	Byte 5	Byte 6	Byte 7
0x7E5	8	0x40	0x19	0x00	0x00	0x01	0x00	0x00	0x00

7. Write the product code: 0X53360000

COB-ID	DLC	Byte 0	Byte 1	Byte 2	Byte 3	Byte 4	Byte 5	Byte 6	Byte 7
0x7E5	8	0x41	0x00	0x00	0x36	0x53	0x00	0x00	0x00

8. Write the revision number: 0x00010020

COB-ID	DLC	Byte 0	Byte 1	Byte 2	Byte 3	Byte 4	Byte 5	Byte 6	Byte 7
0x7E5	8	0x42	0x20	0x00	0x01	0x00	0x00	0x00	0x00

9. Write the serial number: 0x5B2E0100

COB-ID	DLC	Byte 0	Byte 1	Byte 2	Byte 3	Byte 4	Byte 5	Byte 6	Byte 7
0x7E5	8	0x43	0x00	0x01	0x2E	0x5B	0x00	0x00	0x00

The PVE will confirm that LSS has been entered.

COB-ID	DLC	Byte 0	Byte 1	Byte 2	Byte 3	Byte 4	Byte 5	Byte 6	Byte 7
0x7E4	8	0x44	0x00	0x00	0x00	0x00	0x00	0x00	0x00

Now it is possible to configure the Node ID

- DB 0 = LSS Node ID commando
- DB1 = the chosen Node

COB-ID	DLC	Byte 0	Byte 1	Byte 2	Byte 3	Byte 4	Byte 5	Byte 6	Byte 7
0x7E5	8	0x11	0x11	0x00	0x00	0x00	0x00	0x00	0x00

The PVE will respond with the confirmation message

COB-ID	DLC	Byte 0	Byte 1	Byte 2	Byte 3	Byte 4	Byte 5	Byte 6	Byte 7
0x7E4	8	0x11	0x00	0x00	0x00	0x00	0x00	0x00	0x00

Store the new configuration

Use cases

COB-ID	DLC	Byte 0	Byte 1	Byte 2	Byte 3	Byte 4	Byte 5	Byte 6	Byte 7
0x7E5	8	0x17	0x00	0x00	0x00	0x00	0x00	0x00	0x00

The PVE will respond with the confirmation message

COB-ID	DLC	Byte 0	Byte 1	Byte 2	Byte 3	Byte 4	Byte 5	Byte 6	Byte 7
0x7E4	8	0x17	0x00	0x00	0x00	0x00	0x00	0x00	0x00

Leave the configuration mode and activate the new Node ID

COB-ID	DLC	Byte 0	Byte 1	Byte 2	Byte 3	Byte 4	Byte 5	Byte 6	Byte 7
0x7E5	8	0x04	0x00	0x00	0x00	0x00	0x00	0x00	0x00

The PVE will respond with the NMT boot-up message

COB-ID	DLC	Byte 0
0x700 + Node ID	1	0x00

The PVE is now ready to be used in the application.

Use Case 5 – Change of baud rate 250 kbit/s to 500 kbit/s:

Follow the steps below.

1. Power up the PVE-CI.

Boot message from PVE-CI:

COB-ID	DLC	DB0	DB1	DB2	DB3	DB4	DB5	DB6	DB7
0x700 + Node ID*	1	00							

* If Node ID = 0x10 then the COB-ID = 0x710

Emergency message: No error from PVE-CI:

COB-ID	DLC	DB0	DB1	DB2	DB3	DB4	DB5	DB6	DB7
0x80 + Node ID	8	00	00	00	00	00	00	00	00

2. Bring the communication state machine (NMT) from Pre-operational to stop mode by sending the NMT start command.

COB-ID	DLC	DB0	DB1	DB2	DB3	DB4	DB5	DB6	DB7
0x00	2	02	00*						

* 00 = global message

3. Enter LSS:

First transmission:

COB-ID	DLC	DB0	DB1	DB2	DB3	DB4	DB5	DB6	DB7
7E5	8	4	1	0	0	0	0	0	0

4. Change the baud rate according to the table.

Second transmission:

COB-ID	DLC	DB0	DB1	DB2	DB3	DB4	DB5	DB6	DB7
7E5	8	13	0	2	0	0	0	0	0

5. Activate the new baud rate setting.

Third transmission

Use cases

COB-ID	DLC	DB0	DB1	DB2	DB3	DB4	DB5	DB6	DB7
7E5	8	15	0	0	0	0	0	0	0

- Save the new setting (change your master baud rate to 500 kbit/s before saving).

Fourth transmission

COB-ID	DLC	DB0	DB1	DB2	DB3	DB4	DB5	DB6	DB7
7E5	8	17	0	0	0	0	0	0	0

- Reboot your PVE - the baud rate will now be 500 kbit/s.

Use Case 6 – Align cob-id to new configured node id:

Follow the steps below.

- Transmit "LOAD" to align cob-id to new configured node id.

First transmission:

COB-ID	DLC	DB0	DB1	DB2	DB3	DB4	DB5	DB6	DB7
0x600 + Node ID	8	22	11	10	01	6C	6F	61	64

- Transmit "SAVE" to save the new setting.

Second transmission:

COB-ID	DLC	DB0	DB1	DB2	DB3	DB4	DB5	DB6	DB7
0x600 + Node ID	8	22	10	10	01	73	61	76	65

- Reboot your PVE - The cob-id will now be aligned with the new node id.

Products we offer:

- Bent Axis Motors
- Closed Circuit Axial Piston Pumps and Motors
- Displays
- Electrohydraulic Power Steering
- Electrohydraulics
- Hydraulic Power Steering
- Integrated Systems
- Joysticks and Control Handles
- Microcontrollers and Software
- Open Circuit Axial Piston Pumps
- Orbital Motors
- PLUS+1® GUIDE
- Proportional Valves
- Sensors
- Steering
- Transit Mixer Drives

Danfoss Power Solutions is a global manufacturer and supplier of high-quality hydraulic and electronic components. We specialize in providing state-of-the-art technology and solutions that excel in the harsh operating conditions of the mobile off-highway market. Building on our extensive applications expertise, we work closely with our customers to ensure exceptional performance for a broad range of off-highway vehicles.

We help OEMs around the world speed up system development, reduce costs and bring vehicles to market faster.

Danfoss – Your Strongest Partner in Mobile Hydraulics.

Go to www.powersolutions.danfoss.com for further product information.

Wherever off-highway vehicles are at work, so is Danfoss. We offer expert worldwide support for our customers, ensuring the best possible solutions for outstanding performance. And with an extensive network of Global Service Partners, we also provide comprehensive global service for all of our components.

Please contact the Danfoss Power Solution representative nearest you.

Comatrol

www.comatrol.com

Turolla

www.turollaocg.com

Hydro-Gear

www.hydro-gear.com

Daikin-Sauer-Danfoss

www.daikin-sauer-danfoss.com

Local address:

**Danfoss
Power Solutions (US) Company**
2800 East 13th Street
Ames, IA 50010, USA
Phone: +1 515 239 6000

**Danfoss
Power Solutions GmbH & Co. OHG**
Krokamp 35
D-24539 Neumünster, Germany
Phone: +49 4321 871 0

**Danfoss
Power Solutions ApS**
Nordborgvej 81
DK-6430 Nordborg, Denmark
Phone: +45 7488 2222

**Danfoss
Power Solutions Trading
(Shanghai) Co., Ltd.**
Building #22, No. 1000 Jin Hai Rd
Jin Qiao, Pudong New District
Shanghai, China 201206
Phone: +86 21 3418 5200

Danfoss can accept no responsibility for possible errors in catalogues, brochures and other printed material. Danfoss reserves the right to alter its products without notice. This also applies to products already on order provided that such alterations can be made without changes being necessary in specifications already agreed. All trademarks in this material are property of the respective companies. Danfoss and the Danfoss logotype are trademarks of Danfoss A/S. All rights reserved.