



Data Sheet

PLUS+1[®] Extended Memory Controller MC050-128



Mobile Machine Management

The MC050-128 Extended Memory Controller is an element of the flexible, powerful, expandable, and affordable PLUS+1 family of mobile machine management products. This device is a general-purpose controller that is equally suited for use as a member of a distributed machine control system, with intelligence in every node, or as a stand-alone controller.

Product Highlights

The MC050-128 Extended Memory Controller is pin compatible with the PLUS+1 MC050-120 Controller. It employs a 32 bit Cortex-M3 Processor, providing the controller with extremely fast single cycle processing speed and 1024K internal flash. Extended Memory features include 2 MB flash vault memory for application data logging and an application key that enables the use of Danfoss developed GUIDE machine control solutions.

Application Development

Users develop MC050-128 applications with PLUS+1 GUIDE. This Microsoft[®] Windows[®] based development environment features a user-friendly, field proven, icon-based graphical programming tool, application downloader, and service/diagnostic tool.

Features

- User-programmable with PLUS+1 GUIDE (Graphical User Integrated Development Environment)
- Contains application key required to run Danfoss developed machine control application software
- 50 pins: 1 Deutsch[®] DRC connector
- ARM 32 bit Cortex-M3 running at 120 MHz
- FRAM non-volatile memory
- 2 MB flash vault memory
- 12 bit analog-to-digital converter
- 24 inputs
 - 6 universal (DIN/AIN/FreqIN) that are user-defined as either:
 - Analog:* with configurable ranges 0 to 5.25 Vdc (with over range protection) or 0 to 36 Vdc
 - Digital:* pull up (5 Vdc), pull down (0 Vdc) or pull to center (2.5 Vdc)
 - Frequency (timing):* 1 Hz to 10 kHz
 - 10 digital (DIN) configurable as pull up (5 Vdc), pull down (0 Vdc)
 - 4 digital/analog (DIN/AIN) that are user-defined as either:
 - Digital:* pull up (5 Vdc), pull down (0 Vdc) or pull to center (2.5 Vdc)
 - Analog:* 0 to 5.25 Vdc or 0 to 36 Vdc
 - 2 analog (AIN/Temp/Rheo) 0 to 5.25 Vdc or 0 to 10,000 Ohm rheostat
 - 2 fixed range analog (AIN/CAN shield) 0 to 5.25 Vdc or CAN shield pin
- 14 outputs
 - 6 universal (PWMOUT/DOUT/PVGOUT) that are user-defined as either:
 - Digital:* (3 A), configurable as source or sink
 - PWM:* (30 to 4000 Hz), configurable as open or closed loop with current control
 - Analog voltage:* open loop PWM at 4000 Hz
 - Any PWMOUT/DOUT/PVGOUT can be used to provide reference power to one PVG valve
 - 6 digital (DOUT) 3 A, configurable as source only
 - 2 digital/PVG power supply (DOUT/PVG Pwr) 3 A, user configurable; one DOUT/PVG Pwr will power up to three PVGs
- 9 to 36 Vdc power supply, monitored internally
- 2 CAN 2.0 B ports
- Power supply for external sensors rated at 5 Vdc to 500 mA, and regulated internally
- 2 LEDs under user control
- 3 mounting alternatives: stack, end, or side
- CE compliant

MC050-128 Dimensions and Pin Assignments

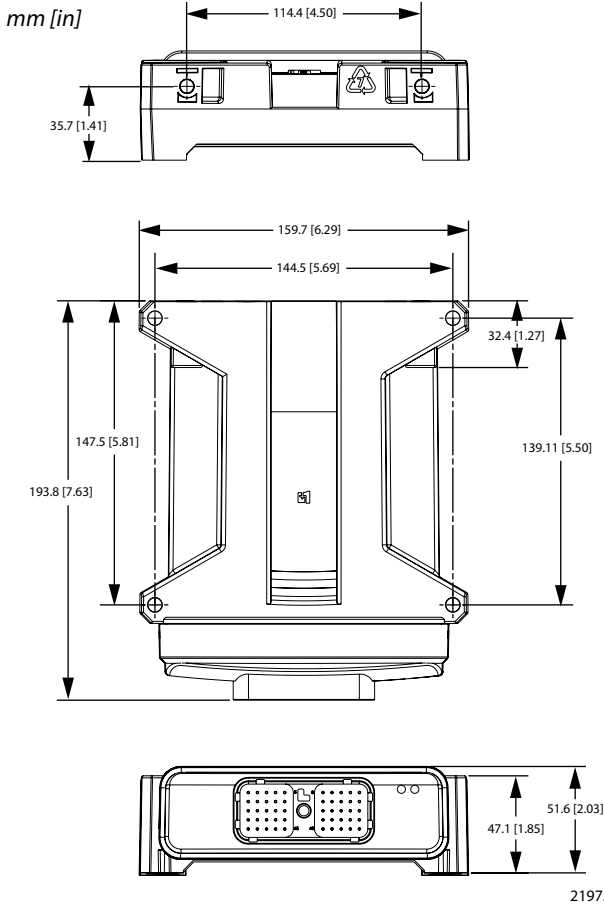

MC050-128 50 pin Connector

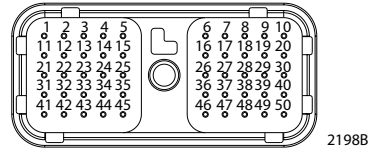

Pin	Controller function	Pin	Controller function
C1-P1	Power ground -	C1-P26	DIN/AIN/FreqIN
C1-P2	Power supply +	C1-P27	DIN/AIN/FreqIN
C1-P3	CAN0 +	C1-P28	DIN/AIN/FreqIN
C1-P4	CAN0 -	C1-P29	DIN/AIN/FreqIN
C1-P5	AIN/CAN1 shield	C1-P30	DIN/AIN/FreqIN
C1-P6	DIN	C1-P31	AIN/Temp/Rheo
C1-P7	DIN	C1-P32	AIN/Temp/Rheo
C1-P8	5 Vdc sensor power +	C1-P33	DOUT
C1-P9	Sensor power ground -	C1-P34	DOUT
C1-P10	DIN	C1-P35	DOUT
C1-P11	DIN	C1-P36	DOUT
C1-P12	DIN	C1-P37	DOUT
C1-P13	DIN	C1-P38	DOUT
C1-P14	DIN	C1-P39	DOUT/PVG Pwr
C1-P15	DIN	C1-P40	DOUT/PVG Pwr
C1-P16	DIN	C1-P41	PWMOUT/DOUT/PVGOUT
C1-P17	DIN	C1-P42	PWMOUT/DOUT/PVGOUT
C1-P18	DIN/AIN	C1-P43	PWMOUT/DOUT/PVGOUT
C1-P19	DIN/AIN	C1-P44	PWMOUT/DOUT/PVGOUT
C1-P20	CAN1 +	C1-P45	PWMOUT/DOUT/PVGOUT
C1-P21	CAN1 -	C1-P46	PWMOUT/DOUT/PVGOUT
C1-P22	AIN/CAN2 shield	C1-P47	Power supply +
C1-P23	DIN/AIN	C1-P48	Power supply +
C1-P24	DIN/AIN	C1-P49	Power supply +
C1-P25	DIN/AIN/FreqIN	C1-P50	Power supply +

Caution
PCB damage may occur. All device power supply + pins must be connected to battery +.

Caution
This device is not field serviceable. Opening the device housing will void the warranty.

Use care when wiring mating connector.
Above pinouts are for device pins.

Specifications

Supply voltage	9 to 36 Vdc
Operating temperature (ambient)	-40°C to 70°C [-40°F to 158°F]
Storage temperature	-40°C to 85°C [-40°F to 185°F]
Programming temperature	-40°C to 70°C [-40°F to 158°F]
IP rating (with mating connector attached)	IP 67
EMI/RFI rating	100 V/m
Weight	0.53 kg [1.16 lb]
Vibration	IEC 60068-2-64
Shock	IEC 60068-2-27 test Ea
Maximum current, sourcing	40 A
Maximum current, sinking	8 A

Ordering Information

MC050-128	11130961
-----------	----------

Related products	Danfoss part numbers	
CG150 CAN/USB gateway	10104136	
Deutsch® mating connector bag assembly	10102024 (16 to 20 AWG)	10100946 (20 to 24 AWG)
PLUS+1 GUIDE single user license	10101079	

Danfoss product literature on line at:
www.danfoss.com

Danfoss Power Solutions (US) Company
2800 East 13th Street
Ames, IA 50010, USA
Phone: +1 515 239 6000

Danfoss Power Solutions GmbH & Co. OHG
Krokamp 35
D-24539 Neumünster, Germany
Phone: +49 4321 871 0

Danfoss Power Solutions ApS
Nordborgvej 81
DK-6430 Nordborg, Denmark
Phone: +45 7488 2222

Danfoss Power Solutions Trading (Shanghai) Co. Ltd.
Building #22, No. 1000 Jin Hai Rd
Jin Qiao, Pudong New District
Shanghai, China 201206
Phone: +86 21 3418 5200

Danfoss can accept no responsibility for possible errors in catalogues, brochures and other printed material. Danfoss reserves the right to alter its products without notice. This also applies to products already on order provided that such alterations can be made without changes being necessary in specifications already agreed. All trademarks in this material are property of the respective companies. Danfoss and the Danfoss logotype are trademarks of Danfoss A/S. All rights reserved.