

ENGINEERING
TOMORROW



Technical Information

Steering Unit

OSPU



Revision history

Table of revisions

Date	Changed	Rev
March 2016	Updated to Engineering Tomorrow design	0202
May 2014	Converted to Danfoss layout - DITA CMS	BA
Aug 2013	First edition	AA

Contents

A wide range of Steering Components

A wide range of Steering Components.....4
 Conversion factors.....5

Technical literature survey

Survey of literature with technical data on Danfoss Steering Components.....6
 OSPU general information.....6

Function

OSPU steering unit.....7

Function

Function, OSPU LS.....8
 Neutral position.....8
 Steering with normal pump supply.....9
 Emergency steering: Failing pump supply.....9

Versions

OSPU LS..... 10
 Load sensing dynamic..... 10
 Non-reaction..... 10
 Amplification, linear.....10
 Amplification, progressive..... 10

Technical data

Displacement, amplification, flow and pressure: OSPU LS 12
 A minimum standby pressure..... 12
 Amplification characteristics 13
 Emergency steering: Pressure capability 13
 Valve functions in OSPU LS steering units..... 14
 Pilot pressure relief valve; (P - T, Qp) characteristic..... 15
 Shock valves..... 15
 Suction valves..... 15
 Check valve in P..... 16
 Check valve function in LS..... 16
 Port thread versions for OSPU LS..... 17

Dimensions

Dimension.....19

Order specifications and weights

Order specifications.....20
 Weights.....20

Code numbers for catalog versions with specifications

Specify your OSPU according to the destinations as in the example underneath the empty scheme:.....21
 Code numbers..... 21

A wide range of Steering Components

A wide range of Steering Components



F500 026

Danfoss is one of the largest producers in the world of steering components for hydrostatic steering systems on off-road vehicles. Danfoss offers steering solutions both at component and system levels. Our product range makes it possible to cover applications of all types - ranging from ordinary 2-wheel steering (also known as Ackermann steering) to articulated steering, automatic steering (e.g. by sensor) and remote controlled steering via satellite. We can offer more than 1,800 different steering units and 250 different priority valves categorized in types, variants and sizes.

For hydrostatic steering systems Danfoss offers:

- Mini steering units with displacements from 32 to 100 cm³/rev [1.95 to 6.10 in³/rev], flow up to 20 l/min [5.28 US gal/min], steering pressure up to 140 bar [2030 psi].
- Steering units with displacements from 40 to 1200 cm³/rev [2.44 to 73.2 in³/rev], flow up to 100 l/min [26.4 US gal/min, steering pressure up to 240 bar [3481 psi].
- Priority valves for rated flows at 40, 80, 120, 160 and 320 l/min [10.6, 21.1, 31.7, 42.3 and 84.5 US gal/min], pressure up to 350 bar [5076 psi].
- Pilot operated flow-amplifiers with amplification factors of 4, 5, 8, 10 or 20 for rated oil flows of 240 and 400 l/min [63.4 and 105.7 US gal/min], steering pressure up to 210 bar [3045 psi].
- Pilot operated steering valve with steering flow up to 100 l/min [26.4 US gal/min], steering pressure up to 250 bar [3625 psi] and with integrated priority valve for pump flow up to 120 l/min [31.7 US gal/min].

For electrohydraulic steering systems Danfoss offers:

- Pilot operated steering valves (pilot operated by hydrostatic steering unit or by electrical signal) with steering flows up to 100 l/min [26.4 US gal/min], steering pressure up to 250 bar [3625 psi].
- Steering units with integrated electrical operated steering valve with steering flow up to 50 l/min [13.2 US gal/min], steering pressure up to 210 bar [3045 psi].

A wide range of Steering Components

Characteristic features for steering units:

- Low steering torque: From 0.5 N•m to 3 N•m in normal steering situations
- Low noise level
- Low pressure drop
- Many types available: Open center Non-reaction, Open center Reaction, Power Beyond, Closed center Non-reaction, Load Sensing, Load Sensing Reaction
- One or more built-in valve functions: relief valve, shock valves, suction valves, non-return valve in P-line and in LS-line
- Optional port connections (according to ISO, SAE or DIN standards)

Characteristic features for electrohydraulic steering systems with OSPE and EHPS:

- Possibility of GPS, row sensor, variable steering ratio and joystick steering
- The possibility of manual steering even on very heavy vehicles
- EHPS: High steering pressure requiring smaller cylinders and flow
- EHPS: Low pilot pressure and flow giving extremely low noise in the cabin
- EHPS: Can be combined with Danfoss PVG 32 proportional valve

Conversion factors

$$1 \text{ N}\cdot\text{m} = [8.851 \text{ lbf}\cdot\text{in}]$$

$$1 \text{ N} = [0.2248 \text{ lbf}]$$

$$1 \text{ mm} = [0.0394 \text{ in}]$$

$$1 \text{ cm}^3 = [0.061 \text{ in}^3]$$

$$1 \text{ l} = [0.264 \text{ US gal}]$$

$$1 \text{ bar} = [14.5 \text{ psi}]$$

$$^{\circ}\text{F} = [1.8^{\circ}\text{C} + 32]$$

Technical literature survey

Survey of literature with technical data on Danfoss Steering Components

Detailed data on all Danfoss steering components and accessories can be found in our steering component catalogues, which is divided in to the following individual sub catalogues:

General information	Steering components
Technical data on mini steering units	OSPM
Technical data on open center, and closed center steering units	OSPB, OSPC, and OSPD
Technical data on load sensing steering units, priority valves and flow amplifiers	OSPB, OSPC, OSPF, OSPD, OSPL, OSPBX, OSPLX, OVPL, OLS and OSQ
Technical data on hydraulic and electrohydraulic pilot operated steering valves, electrical actuation modules and appropriate steering units.	EHPS, EHPS w. OLS 320, PVE for EHPS and OSPCX
Technical data on combined steering unit/electrohydraulic steering valves and steering wheel sensors	OSPE
	SASA
Technical data on load sensing steering unit with amplification	OSPU

For technical information on individual variants, please contact the Danfoss Sales Organization.

OSPU general information

OSPU is a flow amplifying, load sensing steering unit, available with amplification factors 2, 3, or 4. OSPU is a cost-attractive dual displacement steering unit alternative for heavier applications needing reduced displacement for emergency (manual) steering, such as tractors, backhoe loaders, telehandlers, and combines.

The OSPU total displacement ranges from 120-500 cc in normal steer mode (amplified). In emergency steer mode the displacement ranges from 60-125 cc/rev. The standard OSPU has fully linear flow characteristic (flow versus rpm).

OSPU is also available in a version with continuous progressive amplification factor. This feature will make a simple "Fast Steer" steering system possible: it enables higher ratio steering flow at higher rpm meaning less turns lock-lock at higher steering speed. This feature is especially attractive on backhoe loaders and small wheel loaders.

Function

OSPU steering unit

The OSPU includes the following main components:

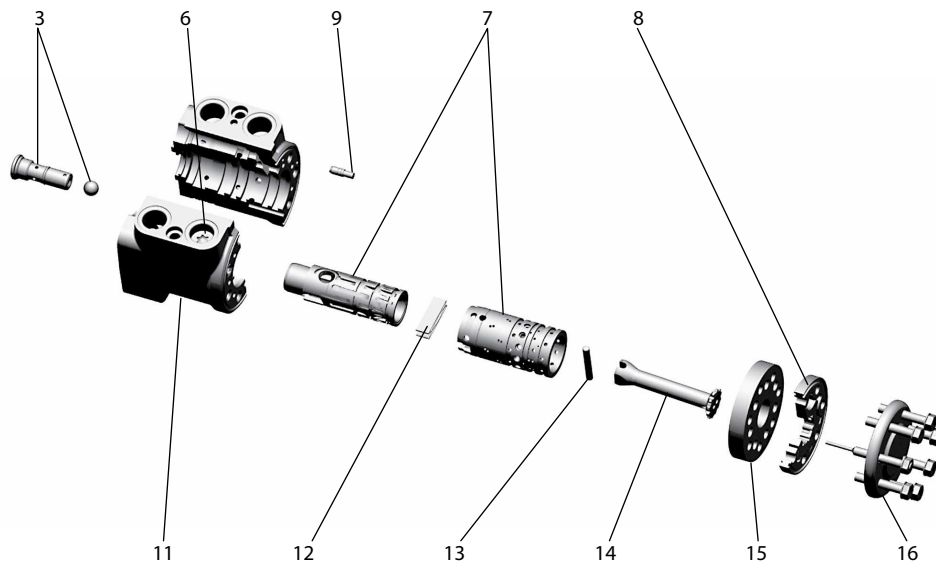

P301 477

Designation of OSPU elements

Item	Description
3	Torque compensator valve
6	P-check valve
7	Spool/sleeve set
8	Gear set
9	LS copy valve
11	Housing
12	Neutral spring package
13	Cross pin
14	Cardan shaft
15	Distributor plate
16	End cover with screws

Function

Function, OSPU LS

Designation of OSPU elements

Item	Description
1	Shock valves
2	Suction valves
3	Torque compensator valve
4	Emergency steering check valve
5	Pilot pressure relief valve
6	P-check valve
7	Spool/sleeve set: including bleeds, A1-A5, Au and Ad
8	Gear set
9	LS copy valve
10	Priority valve, dynamic type

OSPU Danfoss symbols

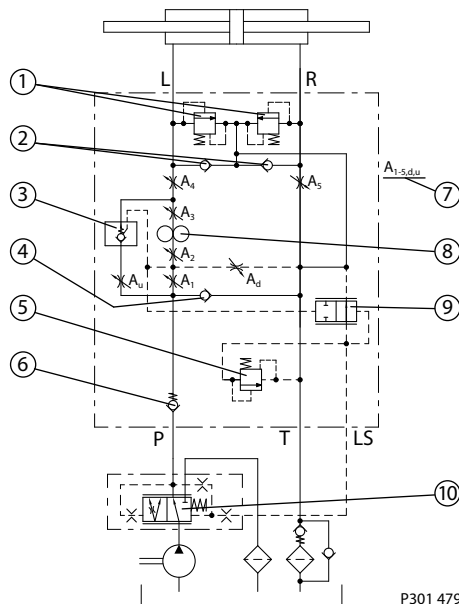

OSPU ISO-symbols

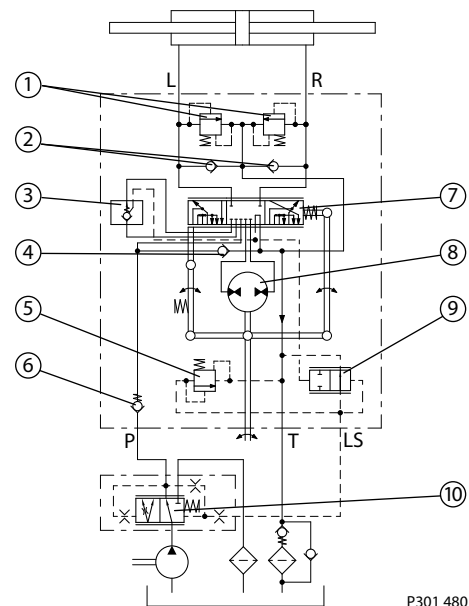

The OSPU is a Load Sensing Dynamic steering unit type with built in amplification function in the spool/sleeve set (7).

The main circuit is identical to other OSP LS steering units like e.g. OSPC: Bleeds of spool/sleeve set (7): A1-A5 and Ad plus gear set (8).

Additionally the OSPU includes an amplification circuit containing the Au bleed in spool/sleeve/set (7) and a torque compensator valve (3).

Furthermore the OSPU contains a LS copy valve (9). This valve is needed to be able to use dynamic priority valve.

Neutral position

The drain bleed Ad of spool/sleeve set (7) is open to tank. All other bleeds, A1-A5 and Au are closed. When the pump runs, the dynamic flow from the LS line of the priority valve (10) will stream across the LS copy valve (9) to tank.

Function

Steering with normal pump supply

When turning the steering wheel, the drain bleed Ad will be closed, and all other bleeds, A1-A5 and Au will open in parallel. Opening area will depend on steering wheel speed. Pressure in LS line will rise according to steering pressure demand: pressure will be transmitted across the LS copy valve (9) and the priority valve (10) will supply the requested oil flow and pressure to P port of the steering unit.

The pump oil flow will be split between the parallel connected inlet bleeds: A1 and Au. The oil flow across A1 is determined by the size of the gear set (8) and the steering wheel speed. The oil flow across Au is determined by the opening area of Au. The amplification will be constantly independent on steering speed under normal steering conditions: pump flow and standby pressure must be within demand for the requested steering speed.

The function of the torque compensator valve (3) is to assure constant amplification: in case pressure drop may occur across the gear set (8) e.g. due to dirt particles entering the steering unit, the torque compensator valve (3) will generate the same pressure drop for the amplified oil.

When steering against end stroke, the steering pressure will be limited by the pilot pressure relief valve (5): pressure in LS line will be limited and so the priority valve will lead the pump flow to EF port of the priority valve and on to tank.

Emergency steering: Failing pump supply

When pressure in P-port does not match the steering pressure requested, the gear set (8) will act as a hand pump, when torque is applied to the steering wheel. The displacement for emergency steering is purely determined by the size of the gear set (8). The check valve function of the torque compensator valve (3) will prevent back stream of oil across the Au bleed.

When pump flow becomes insufficient, the emergency steering check valve (4) will open and oil will be led to the gear set (8) from return side of cylinder, additional flow will be sucked from tank as needed.

Versions

OSPU LS



Load sensing dynamic

In load sensing steering systems both the steering system and the working hydraulics can be supplied from just one pump. In addition LS steering systems make energy saving possible by the use of an LS pump.

Load sensing steering units have a connection for load sensing (LS), so that a load pressure signal can be directed via the steering unit to a Danfoss priority valve and/or an LS pump. The load sensing signal controls the oil flow from the priority valve (and/or the LS pump) to the steering unit.

OSPU are all of load sensing dynamic type and require load sensing dynamic priority valves and/or load sensing variable displacement pumps with “dynamic” control. Load sensing dynamic steering systems have a constant oil flow in the LS connection direction steering unit also when the steering unit is in neutral position.

Non-reaction

With non-reaction steering units there is no corresponding movement of the steering wheel when the driver is not steering the vehicle.

Amplification, linear

The displacement is constant over the entire range of normal steering speed, 0-100 rpm.

Amplification, progressive

The displacement varies over the entire range of normal steering speed, 0-100 rpm.

Versions

OSPU LS: Steering unit load sensing with integrated valve functions

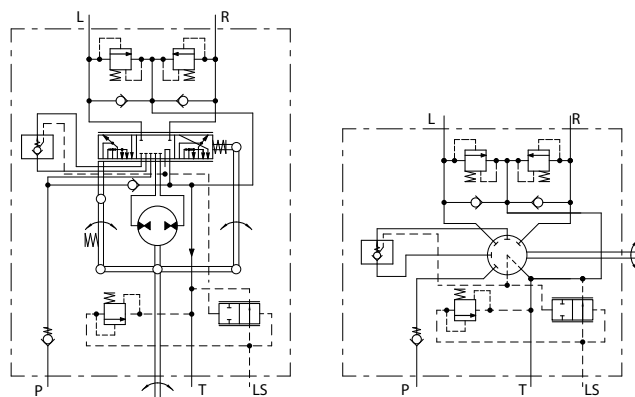

P301 482

Technical data

Displacement, amplification, flow and pressure: OSPU LS

For common data: Look in sub catalog: "General Steering Components"

Steering unit	Amplification	Displacement emergency/ manual steer mode cm ³ /rev [in ³ /rev]	Displacement normal steer mode cm ³ /rev [in ³ /rev]	Rated oil flow* l/min [US gal/min]	Max. pressure, bar [psi]		
					System pressure [†] P-T port pressure	T, absolute port pressure	L-T/R-T port pressure
OSPU 60/120 LS	2	60 [3.66]	120 [7.32]	12 [3.17]	175 [2540]	40 [580]	280 [4060]
OSPU 60/180 LS	3	60 [3.66]	180 [10.98]	18 [4.76]			
OSPU 60/240 LS	4	60 [3.66]	240 [14.65]	24 [6.34]			
OSPU 70/140 LS	2	70 [4.27]	140 [8.54]	14 [3.70]			
OSPU 70/210 LS	3	70 [4.27]	210 [12.81]	21 [5.55]			
OSPU 70/280 LS	4	70 [4.27]	280 [17.09]	28 [7.40]			
OSPU 80/160 LS	2	80 [4.88]	160 [9.76]	16 [4.23]	210 [3045]		
OSPU 80/240 LS	3	80 [4.88]	240 [14.65]	24 [6.34]			
OSPU 80/320 LS	4	80 [4.88]	320 [19.53]	32 [8.45]			
OSPU 100/200 LS	2	100 [6.10]	200 [12.20]	20 [5.28]			
OSPU 100/300 LS	3	100 [6.10]	300 [18.31]	30 [7.93]			
OSPU 100/400 LS	4	100 [6.10]	400 [24.41]	40 [10.57]			
OSPU 125/250 LS	2	125 [7.63]	250 [15.26]	25 [6.60]			
OSPU 125/375 LS	3	125 [7.63]	375 [22.88]	38 [10.03]			
OSPU 125/500 LS	4	125 [7.63]	500 [30.51]	50 [13.21]			

* Rated flow at 100 rpm steering speed.

† Any OSPU can withstand 210 bar in max. system pressure. However OSPU w. small gear wheel set and high pressure will have relatively high slippage values (slippage will be on level with e.g. OSPC with same gear wheel set)

A minimum standby pressure

(P-LS) is needed to achieve the defined amplification characteristic (linear or progressive) up to a certain maximum steering speed wanted.

Steering unit	Amplification	Min. standby pressure*, P-LS bar [psi]		
		For max steering speed 80 rpm	For max steering speed 100 rpm	For max steering speed 120 rpm
OSPU 60/120 LS	2	6	8	9
OSPU 60/180 LS	3	7	10	12
OSPU 60/240 LS	4	9	13	15
OSPU 70/140 LS	2	7	10	11
OSPU 70/210 LS	3	8	11	13
OSPU 70/280 LS	4	10	14	17
OSPU 80/160 LS	2	8	11	12
OSPU 80/240 LS	3	9	12	13
OSPU 80/320 LS	4	13	15	18
OSPU 100/200 LS	2	9	11	13
OSPU 100/300 LS	3	10	12	15
OSPU 100/400 LS	4	15	19	---
OSPU 125/250 LS	2	10	12	14

Technical data

Steering unit	Amplification	Min. standby pressure*, P-LS bar [psi]		
		For max steering speed 80 rpm	For max steering speed 100 rpm	For max steering speed 120 rpm
OSPU 125/375 LS	3	11	13	---
OSPU 125/500 LS	4	18	---	---

* Values valid for viscosity range 12-80 mm²/s [66-370 SUS] and temperature range of 30-60°C [86-140°F]

Missing values will be added when available.

Amplification characteristics

OSPU with linear amplification has constant displacement independent on steering speed inside normal steering speed range, 0-100 rpm, e.g. OSPU 100/200 LS "Linear" has 200 cm³/rev.

In OSPU with progressive amplification the displacement varies over the entire range of normal steering speed, 0-100 rpm. OSPU 100/200 LS "Progressive" has the following nominal displacements:

- 115 cc/rev at >0~5rpm: 15% amplification
- 150 cc/rev at ~50 rpm: 50% amplification
- 200 cc/rev at ~100 rpm: 100% amplification

Metered out flow for OSPU 100 shown with amplification factors possible.

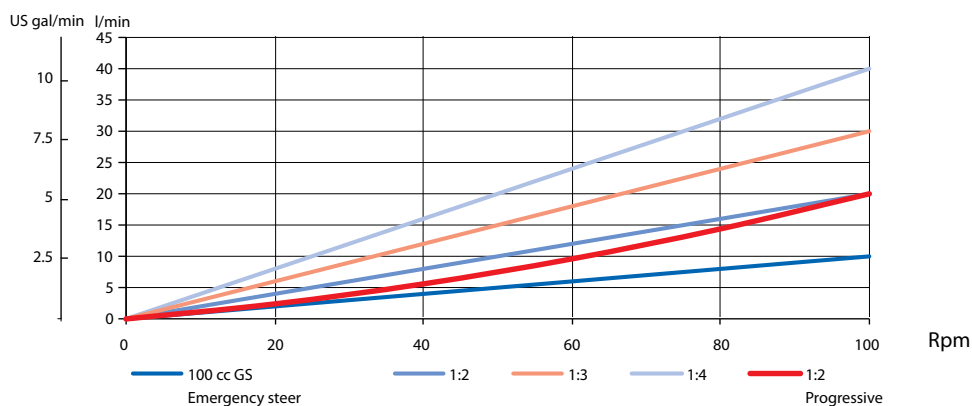

P301 448

Emergency steering: Pressure capability

The steering unit can be used as a hand pump if oil supply to the steering unit fails.

Below graph can be used as a design guide to choose the needed size of gear set for the OSPU:

- Determine steering pressure required for the emergency steering maneuver and draw a horizontal line from this value for Pressure
- Determine manual input torque allowed on steering wheel and draw a vertical line from this value for Torque
- The largest steering unit displacement suitable is the first angled line to the left of intersection. An example is shown w. 25 bar [362 psi] pressure demand, and 38 Nm [336 lbf·in] allowed manual input torque: OSPU 80/xxx, OSPU 70/xxx or OSPU 60/xxx are suitable to build up enough pressure for emergency steering.

Technical data

OSPU LS emergency steer curves

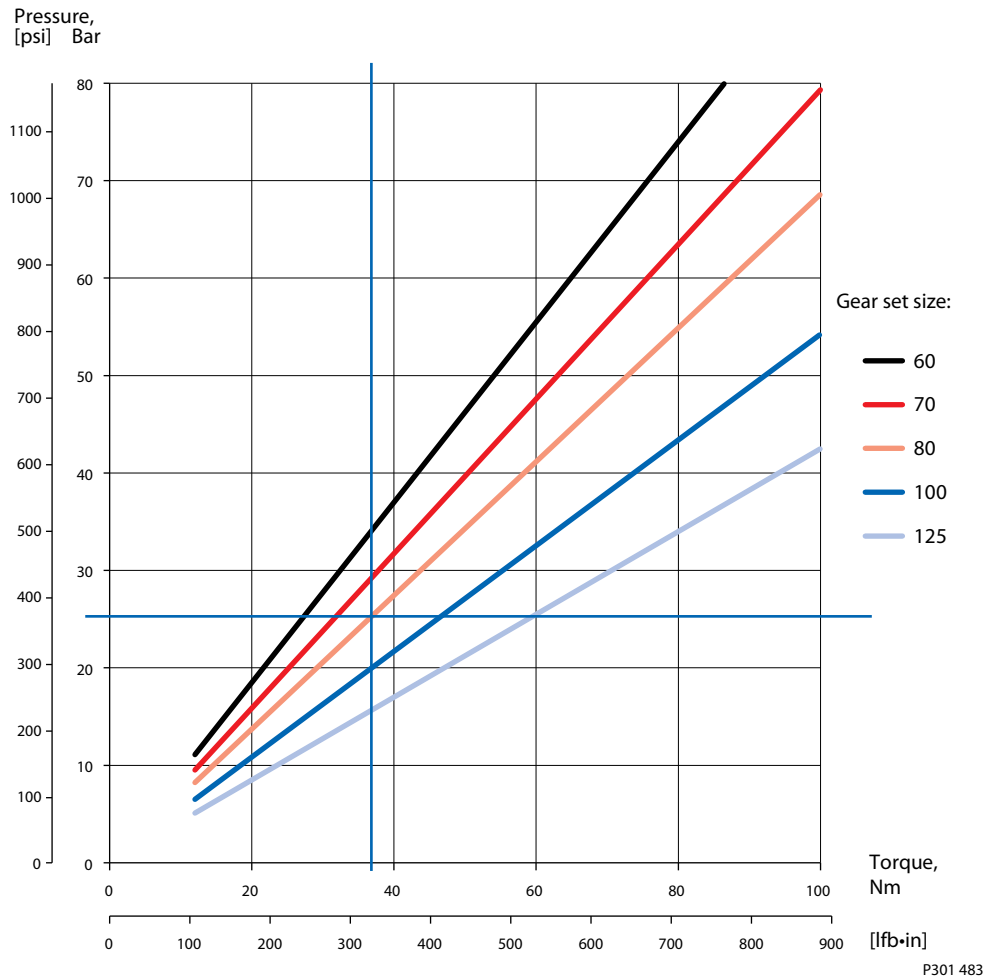

Only physical testing on the vehicle in question can verify if the demands for emergency steer capability will be fulfilled.

Valve functions in OSPU LS steering units

All OSPU have the following valves built in as standard:

- Emergency steering check valve (4)
- P-check valve (7)
- Check valve function in LS:
 LS copy valve (5)
- Suction valves (2)
- Torque compensator valve (3)

OSPU can have built in the following valves (option):

- Pilot pressure relief valve (6)
- Shock valves (1)

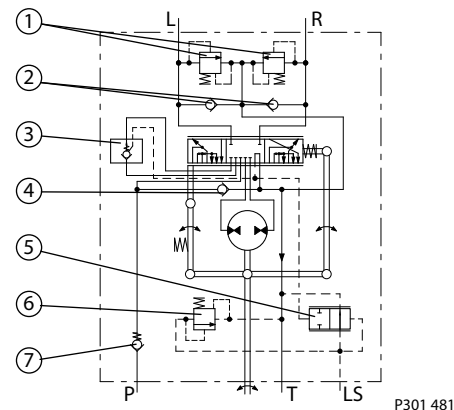

Technical data

Pilot pressure relief valve; (P - T, Q_p) characteristic

The pilot pressure relief valve protects the steering unit against excessive pressure. The pilot pressure relief valve in the OSPU LS steering unit together with the priority valve limits the maximum steering pressure P-T. The pilot pressure relief valve is set at an oil flow to the priority valve of 25 l/min [6.60 US gal/min].

For OSPU Load Sensing dynamic steering units, the setting values are valid at a dynamic flow of 1.1 l/min [0.29 US gal/min]

Setting tolerance:

< / = 170 bar [2645 psi]: rated value +5 bar [72.5 psi].

> 170 bar [2645 psi]: rated value +10 bar [145 psi].

A = 170⁺⁵₀ bar [2465⁺⁷³₀ psi]

B = 140⁺⁵₀ bar [2030⁺⁷³₀ psi]

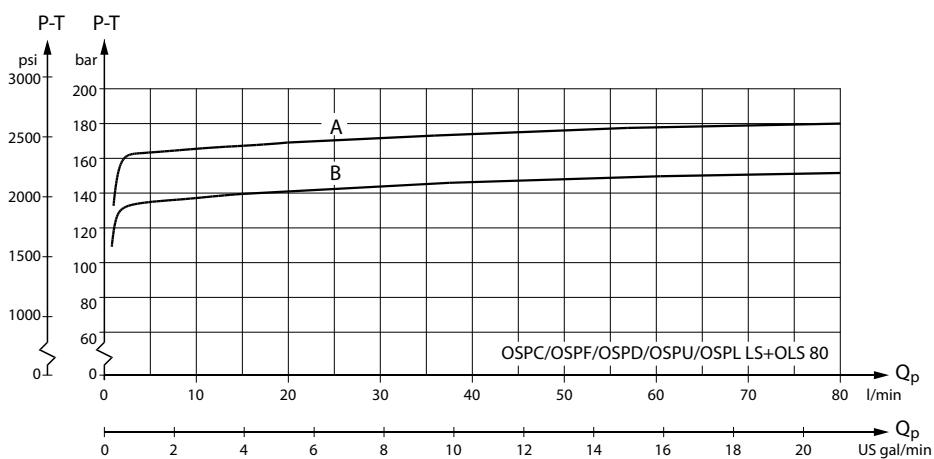

152B79.10

Shock valves

The shock valves protect the steering unit and reduce external forces on the steering cylinder by limiting the pressure difference from L to T and from R to T.

The shock valves are set at 3 l/min [0.792 US gal/min]

At higher flow pressure peaks may occur.

The shock valves are of the direct acting type, so they react very quickly.

Setting tolerance: rated value +20 bar [290 psi].

Suction valves

The suction valves allow oil suction to avoid cavitation in the steering cylinder. To provide correct suction, a back pressure valve must be fitted in the tank line from the steering unit.

Generally Danfoss recommend a back pressure of 2 bar [29 psi], but on vehicles with strong self-straightening tendencies and on articulated steered vehicles, we recommend 5-10 bar [72.5 - 145 psi]. For further advice, please contact the Danfoss Sales Organisation.

[A connection which incorporates a check valve must be established to allow oil flow to by-pass the back pressure valve \(and filter\) from the tank to steering unit. See OSPU LS diagram examples.](#)

Technical data

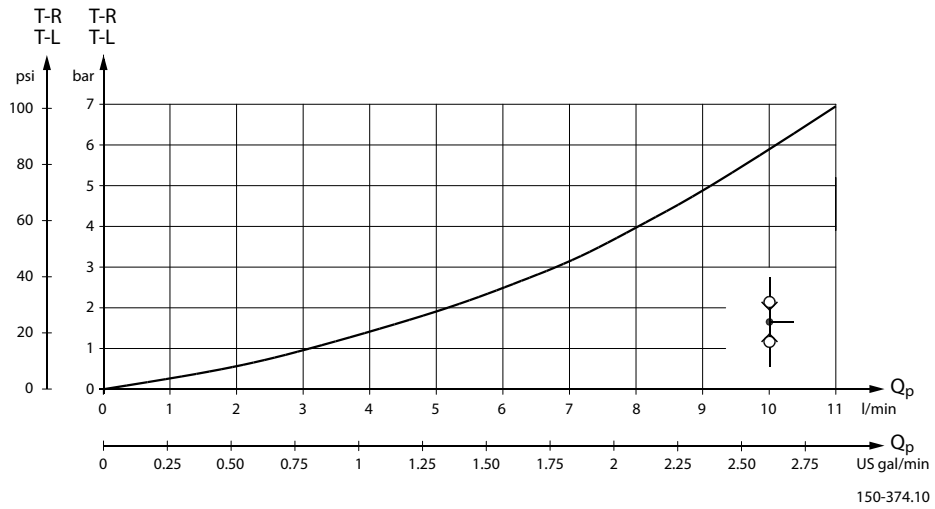

Check valve in P

The check valve in the P connection of the steering unit protects the driver against steering wheel jerks. The check valve prevents oil from flowing backwards into the pump line when steering against a high pressure on the cylinder side. The pressure drop across the check valve is indicated on the following graph, which assumes the use of port adaptors with 11 mm [0.43 in] minimum bore.

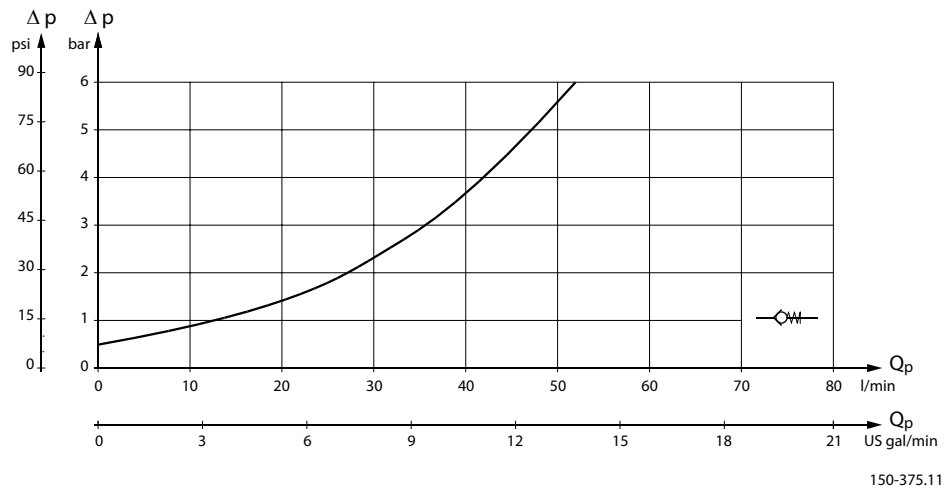

Check valve function in LS

The LS copy valve of OSPU protects the driver against steering wheel jerks. The LS copy valve prevents oil from flowing backwards into the LS line to the priority valve when steering against a high pressure on the cylinder side.

Technical data

Port thread versions for OSPU LS

B: G port w. spot face (LS)
L: DIN 3852-2 - G ¼

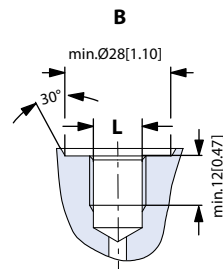

150-603.10-B

D: G ports w. spot face (P, T, L, R)
N: DIN 3852-2 - G ½

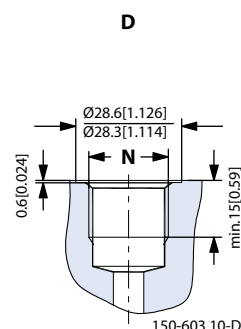

150-603.10-D

E: Metric port w. spot face and O-ring chamfer (LS)
O: ISO 6149-1 - M12 x 1.5

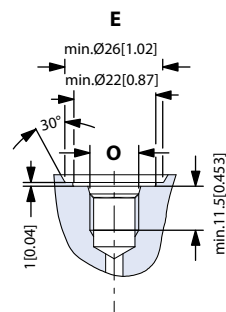

150-603.10-E

F: Metric ports w. spot face and O-ring chamfer (P, T, L, R)
P: ISO 6149-1 - M18 x 1.5

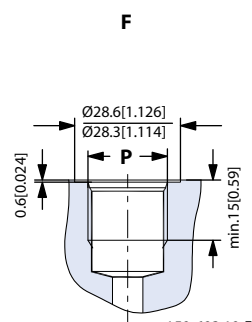

150-603.10-F

Technical data

H: UNF ports w. O-ring chamfer (LS)
R: ISO 11926-1
 7/16-20 UNF O-ring boss port

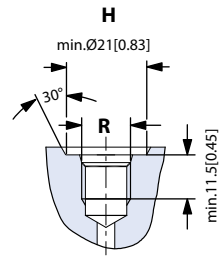

150-603.10-H

I: UNF ports w. O-ring chamfer (P, T, L, R)
S: ISO 11926-1 3/4-16UNF O-ring boss port

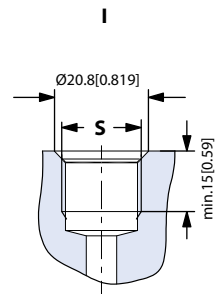

150-603.10-I

Dimensions

Dimension

OSPU LS

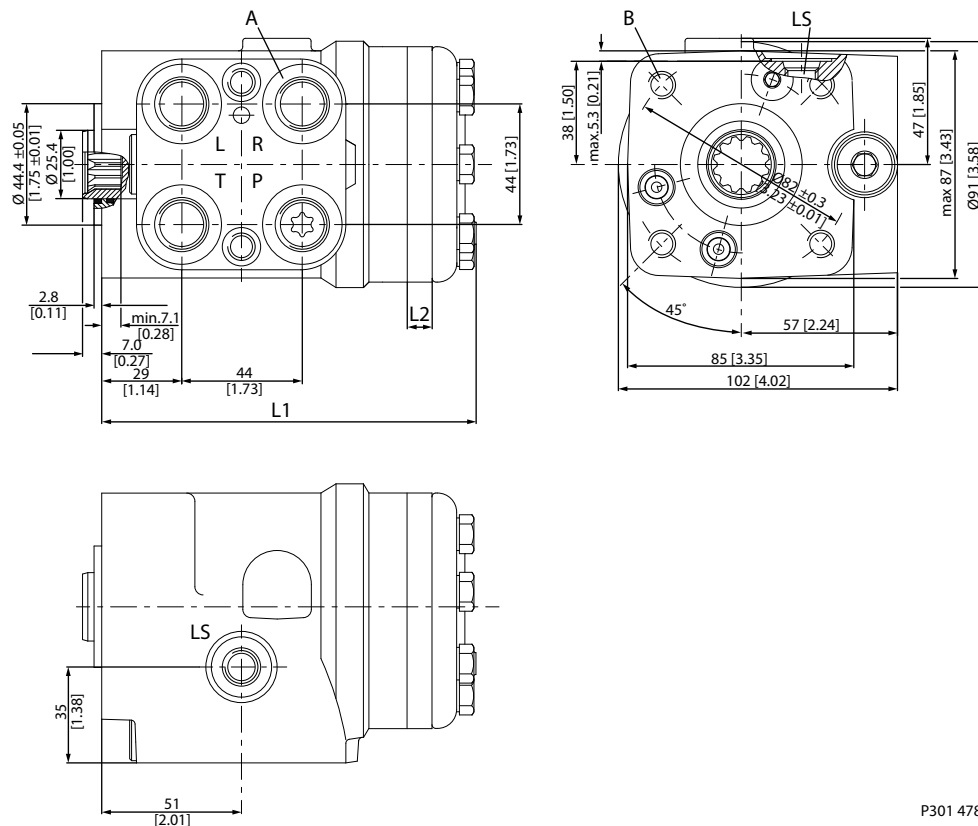

P301 478

European version:

A: G ½ w. spot face (G, DIN 3852-2) 15 mm [0.59 in] deep
 or
 M18 x 1.5 ISO 6149-1, 15 mm [0.59 in] deep

B: M10 x 1.5, 16 mm [0.63 in] deep

LS: G 1/4 w. spot face (G, DIN 3852-2) 12 mm [0.47 in] deep
 or
 M12 x 1.5 ISO 6149-1, 11.5 mm [0.45 in] deep

US version:

A: 3/4 - 16 UNF O-ring boss ISO 11926-1 15 mm [0.59 in] deep

B: M 10 x 1.5, 16 mm [0.63 in] deep,

LS: 7/16 - 20 UNF o-ring boss ISO 11926-1, 11.5 mm [0.45 in] deep

Type	L1, mm [in]	L2, mm [in]
60/xxx	137 [5.39]	7.8 [0.31]
70/xxx	138 [5.43]	9.1 [0.36]
80/xxx	139 [5.47]	10.4 [0.41]
100/xxx	142 [5.59]	13.0 [0.51]
125/xxx	145 [5.71]	16.2 [0.64]

Order specifications and weights

Order specifications

Variants, OSPU

Gear set, displacement	cm ³ /rev	60	70	80	100	125
Amplified displacement*	cm ³ /rev	120, 180, 240	140, 210, 280	160, 240, 320	200, 300, 400	250, 375, 500
Spool/sleeve set	Type	LS: Load Sensing dynamic, non-reaction				
Amplification	Characteristic	L: Linear		P: Progressive (only available w. amplification factor "2")		
Housing†	Thread	M: Metric	G		U: UNF	
Relief valve	Bar	100 – 210 (N for no relief valve wanted)				
Shock valves	Bar	160 – 260 (N for no shock valves wanted)				

* Amplification factors available, linear: 2, 3 or 4

† Housing, threads:

	P, T, L & R	LS
Metric, ISO 6149-1	M 18 x 1.5 – O* + S**	M 12 x 1.5 – O* + S**
G, DIN 3852-2	G ½ - S**	G ¼ - S**
UNF O-ring boss ISO 11926-1	¾ - 16 UNF – O*	7/16 - 20 UNF – O*

O* O-ring chamfer on port connection

S** Spot face around port connection

All OSPU's have the following valves included:

- Manual Steering Check Valve
- Inlet Check Valve in P-port
- Check Valve function in LS
- Suction Valves in cylinder ports
- Torque Compensator Valve

Weights

Type OSPU	Weight kg [lb]
60/xxx	5.3 [11.47]
70/xxx	5.4 [11.90]
80/xxx	5.5 [12.13]
100/xxx	5.6 [12.35]
125/xxx	5.8 [12.79]

Code numbers for catalog versions with specifications

Specify your OSPU according to the destinations as in the example underneath the empty scheme:

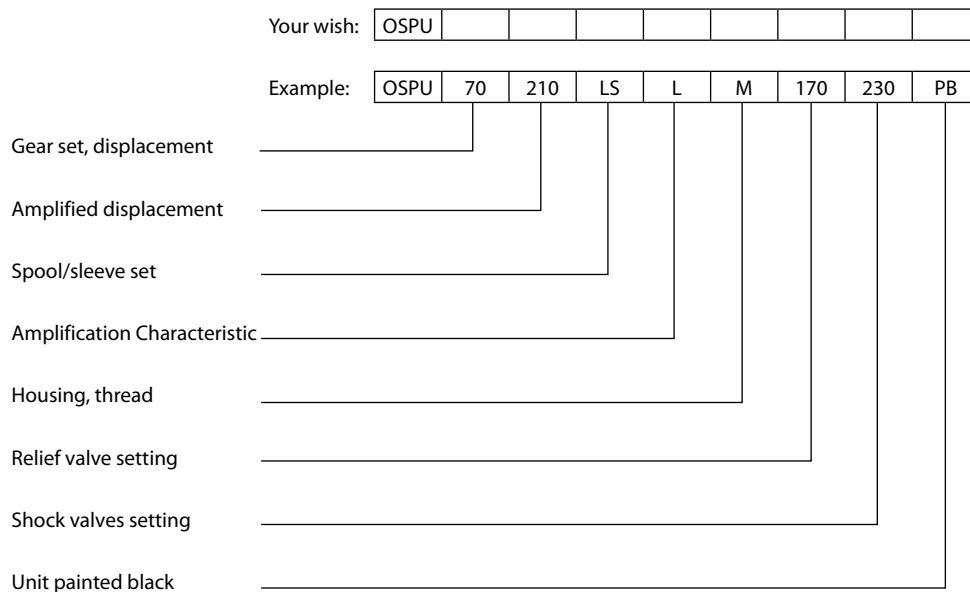

Code numbers

Code numbers	Specifications according to above description format								
11131317	OSPU	70	210	LS	L	M	170	230	PB

Products we offer:

- Bent Axis Motors
- Closed Circuit Axial Piston Pumps and Motors
- Displays
- Electrohydraulic Power Steering
- Electrohydraulics
- Hydraulic Power Steering
- Integrated Systems
- Joysticks and Control Handles
- Microcontrollers and Software
- Open Circuit Axial Piston Pumps
- Orbital Motors
- PLUS+1® GUIDE
- Proportional Valves
- Sensors
- Steering
- Transit Mixer Drives

Danfoss Power Solutions is a global manufacturer and supplier of high-quality hydraulic and electronic components. We specialize in providing state-of-the-art technology and solutions that excel in the harsh operating conditions of the mobile off-highway market. Building on our extensive applications expertise, we work closely with our customers to ensure exceptional performance for a broad range of off-highway vehicles.

We help OEMs around the world speed up system development, reduce costs and bring vehicles to market faster.

Danfoss – Your Strongest Partner in Mobile Hydraulics.

Go to www.powersolutions.danfoss.com for further product information.

Wherever off-highway vehicles are at work, so is Danfoss. We offer expert worldwide support for our customers, ensuring the best possible solutions for outstanding performance. And with an extensive network of Global Service Partners, we also provide comprehensive global service for all of our components.

Please contact the Danfoss Power Solution representative nearest you.

Comatrol

www.comatrol.com

Schwarzmueller-Inverter

www.schwarzmueller-inverter.com

Turolla

www.turollaocg.com

Hydro-Gear

www.hydro-gear.com

Daikin-Sauer-Danfoss

www.daikin-sauer-danfoss.com

Local address:

Danfoss Power Solutions (US) Company
2800 East 13th Street
Ames, IA 50010, USA
Phone: +1 515 239 6000

Danfoss Power Solutions GmbH & Co. OHG
Krokamp 35
D-24539 Neumünster, Germany
Phone: +49 4321 871 0

Danfoss Power Solutions ApS
Nordborgvej 81
DK-6430 Nordborg, Denmark
Phone: +45 7488 2222

Danfoss Power Solutions Trading (Shanghai) Co., Ltd.
Building #22, No. 1000 Jin Hai Rd
Jin Qiao, Pudong New District
Shanghai, China 201206
Phone: +86 21 3418 5200

Danfoss can accept no responsibility for possible errors in catalogues, brochures and other printed material. Danfoss reserves the right to alter its products without notice. This also applies to products already on order provided that such alterations can be made without changes being necessary in specifications already agreed. All trademarks in this material are property of the respective companies. Danfoss and the Danfoss logotype are trademarks of Danfoss A/S. All rights reserved.