

Data Sheet

Steering Valve Controller

PVED-CLS on OSPE



Electrohydraulic Steering

The PVED-CLS Steering Valve Controller is an application specific valve controller for the Danfoss steering valve family. The PVED-CLS offers integrated flexible software-based electrohydraulic steering functionality which can be tailored to any off-road vehicle type by software parameterization. The PVED-CLS also works as a certified Safety Controller.

System Integration

Users integrate and develop the electro-hydraulic steering system by adjusting typically 20 parameters with a CAN bus based service and diagnostic tool. Danfoss offers a graphical-based tool (PLUS+1[®] Service Tool).

Safety

Safety functions for electrohydraulic steering are integrated and designed to

- SIL2 (IEC 61508)
- PL d (ISO 13849) and
- AgPL d (EN 16590)
- AgPL e for roading mode can be achieved by additional circuitry (hydrostatic steering only)

Features

- Mount on OSPE, EHPS, EH valves
- User-programmable steering functionality
- Use for front-, rear- or articulated steered vehicles
- Category 3 safety architecture (dual microcontroller)
- 12 pin DEUTSCH DT connector
- CAN based Wheel Angle Sensor input
- 9 to 32 Vdc power supply operation
- 5V Power supply for external sensors (250mA)
- 2 CAN 2.0B ports, baud rate (250Kbit/s)
- 1 high-side switch output (9 to 32Vdc, 2A@12Vdc) (e.g. for OSPE cut-off valve control)
- 1 LED for operational mode indication
- Designed for SASA steering wheel sensor
- Prepared for steering devices with tactile feedback (AUX steering)
- Functional safety conforms to IEC 61508, ISO 13849 and EN 16590 (ISO 25119:2010 modified)
- Fail-silent electrohydraulic steering principle
- Suitable for safety architecture categories 2 and 3
- Safe on-road mode (SIL 3/AgPL e, electronics powered, and EH steering depowered)
- Main safety functions
 - Safe state: Redundant shutting-off the electrohydraulic steering flows (system fall-back hydrostatic OSP steering)
 - Trip to safe state when vehicle speed > safe speed threshold
 - Trip to safe state by unintended steering motion or other malfunction
 - Safe on-road mode

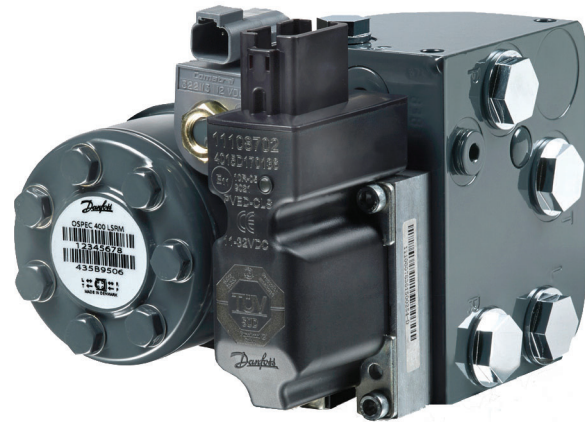

Product highlights

Two Microcontroller-Units (MCU) execute the configurable electrohydraulic steering functionalities such as:

- Integrated safety functions
- Auto-steering (ISO 11783)
- Fast steering (Variable steering ratio)
- Speed dependent characteristics
- AUX interface
 - Joystick steering
 - Electric Mini-wheel
- Flow ramping for Jerk elimination for articulated vehicles
- Steering wheel anti-drift control
- MMI CAN bus interface
- KWP2000 CAN service protocol
- J1939-73 Diagnostics

Comprehensive technical literature online at
powersolutions.danfoss.com

Dimensions

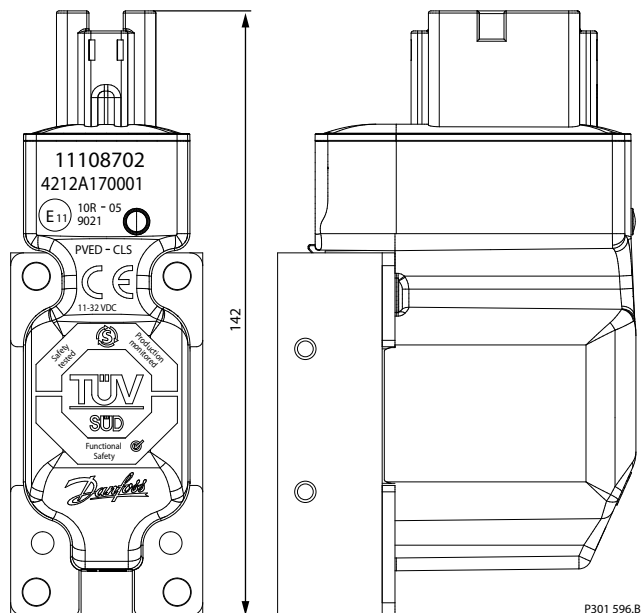

Module/Size	Depth mm	Width mm	Height mm
PVED-CLS	84	45	142

12 pin DEUTSCH DT connector

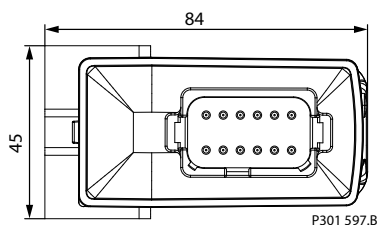

Pin	Controller function
1	AD2 (AIN)
2	AD3 (AIN)
3	Sensor power ground -
4	CAN_H_SAFETY
5	CAN_L_SAFETY
6	Digital output (high-side power switch)
7	Power ground -
8	Power supply +
9	CAN_L_MAIN
10	CAN_H_MAIN
11	5V sensor supply +
12	AD1 (AIN)

Use care when wiring mating connector. Above pinouts are for device pins.

Specifications

Supply voltage	9 to 36 Vdc
Operating temperature (ambient)	-40 °C to 90 °C
Storage temperature	-40 °C to 110 °C
IP rating (with mating connector attached)	IP 67 (bounded by DEUTSCH connector specification)
Connector type	DT04-12PA-B016
EMI/RFI rating	ISO 14982:1998; ISO 11452-2:2004; ISO 13766:2006; EN 13309:2010 (ISO 11452-2)
Weight	0.5 kg
Vibration	EN 60068-2-6:1996; EN 60068-2-64:2009
Shock	EN 60068-2-29 (BS):1993
Functional safety	IEC 61508:2010 ISO 25119:2010 EN 16590:2014 ISO 13849-1:2008 ISO 13849-2:2010 Certificate number Z10150647358001
Software integrity	SIL 2 (IEC61508:2010); SRL 3 (EN 16590:2014)
Architecture category PVED-CLS, OSPE valve	3; (EN 16590:2014; ISO 13849-1:2008)
PFHd for sensors MTTFd for sensors	Refer to sensor manufacturer data-sheet. Achievable diagnostic coverage with PVED-CLS ≥ 90%.
PFHd for PVED-CLS and valve MTTFd for PVED-CLS and valve Safe Failure Fraction	1.68 x 10 ⁻⁸ (IEC 61508:2010) 36 years (per channel, EN 16590:2014) (SN29500 @ 80 °C)
MTTFd for valves	150 years
CE conformity	EMC directive 2004/108/EC; EMC directive 2009/64/EC
EC type approval	E-mark UNECE R10 (Approval number 10R-059021)

Related product	Danfoss part numbers
SASA IID steering wheel sensor	11116505; MTTFd = 73 years (SN29500 @t 80 °C)
CG150 CAN/USB Gateway	10104136, 11153051
Compatible auxiliary steering devices	Contact Danfoss PAE

The product is tested to extended test specifications. Contact Danfoss PAE for further information.

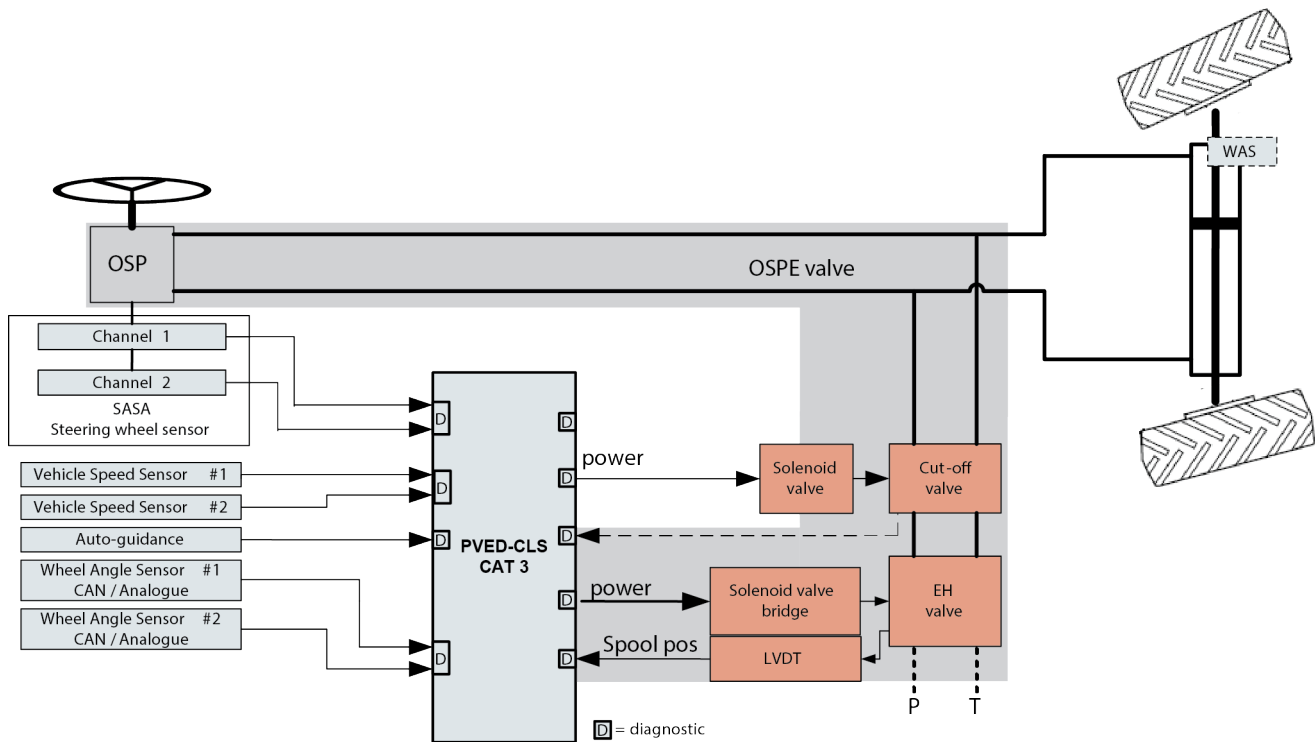

P301 598.B

Concept

A category 3 (EN 16590:2014, ISO 13849:2008) architecture is designed for safe electrohydraulic steering functions satisfying AgPL d and PL d respectively. It executes both the steering functionality as well as the safety functions. One-fault tolerance on the valve sub-system is achieved by using a category 3 valve sub-system (EH-valve and OSPE cut-off valve). When the electrohydraulic flow to the cylinder is isolated (fail safe), the system reverts to a hydrostatic steering architecture.

Safety functions

The PVED-CLS executes four high-level safety functions;

- 'Safe EH-steering shut-off'
- 'Vehicle speed triggered EH-steering shut-off',
- 'Safe EH-steering' and
- 'Safe on-road mode'.

AgPL/PL d is realizable by utilizing a suitable sensor configuration.

'Safe EH-steering' avoids unintended EH-steering flows. If an unintended EH steering flow or any other malfunction is detected, the safe state is demanded.

'Safe on-road mode' can be enabled if PVED-CLS software functionality is desired while used on public road (hydrostatic steering only).

Diagnostic performance

The category 3 architecture property allows using the 1oo2 voting principle which supports achieving a diagnostic coverage $\geq 90\%$. Furthermore, for receiving CAN data, a safety protocol ensures the necessary means for detecting failures in the communication. The MMI input, SASA input, CAN-based wheel angle input, auxiliary steering input and vehicle speed information is supplied via CAN bus. For the highest safety integrity, two messages are received and the CAN message contents is cross-checked by the microcontrollers. Each CAN message conforms to a safety protocol.

The PVED-CLS utilizes two loosely coupled microcontrollers which both execute the control functions and the safety functions. Input, intermediate and output data are periodically interchanged and compared. If a discrepancy is detected, the safe state is demanded and a diagnostic code is transmitted on the CAN (J1939-73).

Valve diagnostic

The EH-valve is tested at power-up and continuously by means of the LVDT sensor. The OSPE solenoid valve and cut-off valve is tested every time an EH-steering functionality is requested by the MMI.