



Service Manual
Steering Valve
OSPE



Revision history*Table of revisions*

Date	Changed	Rev
August 2015	Codenummer changed	0001
February 2015	First edition	AA

Service Manual OSPE Steering Valve

Contents
Safety Precautions

Safety Precautions.....4

Service Literature

Symbols Used in Danfoss Literature.....5

OSPE versions.....5

Exploded View and Seal Kit

OSPE exploded view.....6

OSPE parts list.....7

Tools

Tools for OSPE..... 10

Dismantling

Dismantling OSPE..... 12

Assembly

Assembling OSPE..... 26

Test and valve setting of OSPE

Set up for testing.....42

 Set up OSPE with integrated priority valve.....42

 Set up OSPE without integrated priority valve.....43

Steering test.....43

Pilot relief valve.....44

Neutral positioning test, OSP part.....44

Neutral positioning test, EH part.....44

Manual steering.....44

Shock valves.....44

 OSPE LSRM.....44

 OSPE LS (non reaction/non reaction versions).....44

Check for external leakage.....45

Tightening Torques

Tightening torques for connections OPSE.....46

Safety Precautions**Safety Precautions**

Always consider safety precautions before beginning a service procedure. Protect yourself and others from injury. Take the following general precautions whenever servicing a hydraulic system.

 **Warning**

Unintended Machine Movement

Unintended movement of the machine or mechanism may cause injury to the technician or bystanders. To prevent unintended movement, secure the machine or disable / disconnect the mechanism while servicing.

 **Warning**

Flammable Cleaning Solvents

Some cleaning solvents are flammable. To eliminate the risk of fire, do not use cleaning solvents in an area where a source of ignition may be present.

 **Warning**

Fluid under Pressure

Escaping hydraulic fluid under pressure can have sufficient force to penetrate your skin causing serious injury and/or infection. This fluid may also be hot enough to cause burns. Use caution when dealing with hydraulic fluid under pressure. Relieve pressure in the system before removing hoses, fittings, gauges, or components. Never use your hand or any other body part to check for leaks in a pressurized line. Seek medical attention immediately if you are cut by hydraulic fluid.

 **Warning**

Personal Safety

Protect yourself from injury. Use proper safety equipment, including safety glasses, at all times.

 **Warning**











Product Safety

Steering valves are safety components and therefore it is extremely important that the greatest care is taken when servicing these products. There is not much wear on a steering valve and therefore they normally outlast the application they are built into. Therefore the only recommended service work on steering valves is:

- Changing seals and o-rings
 - Disassemble, clean and assemble if contaminated
 - Make hydraulic testing including valve setting.
-

Service Literature

Symbols Used in Danfoss Literature

-  = Non removable part, use a new part
-  = External hex head
-  = Internal hex head
-  = Lubricate with hydraulic fluid
-  = Inspect for wear or damage
-  = Note correct orientation
-  = Mark orientation for reinstallation
-  = Torque specification
-  = Press in - press fit
-  = Pull out with tool - press fit

OSPE versions

This service literature is valid for:

- All OSPE's with single stage gear set
- All OSPED with dual gear set. For the gear set end however only for V2/OSPED in new design

If the OSPED in question is in "old" or "V2/new" design can be traced by the product code:

- OSPED's with product code number higher than 11113069 are all in "new" design
- OSPED's with product code lower than 11113069 are all in "old" design

For further explanations between OSPED in "old" and "new" design, see Product Information Bulletin ST2014-0139.

Service literature HN.21.ZA.52 is valid for gear set end of OSPED in "old" version.

Exploded View and Seal Kit

OSPE exploded view

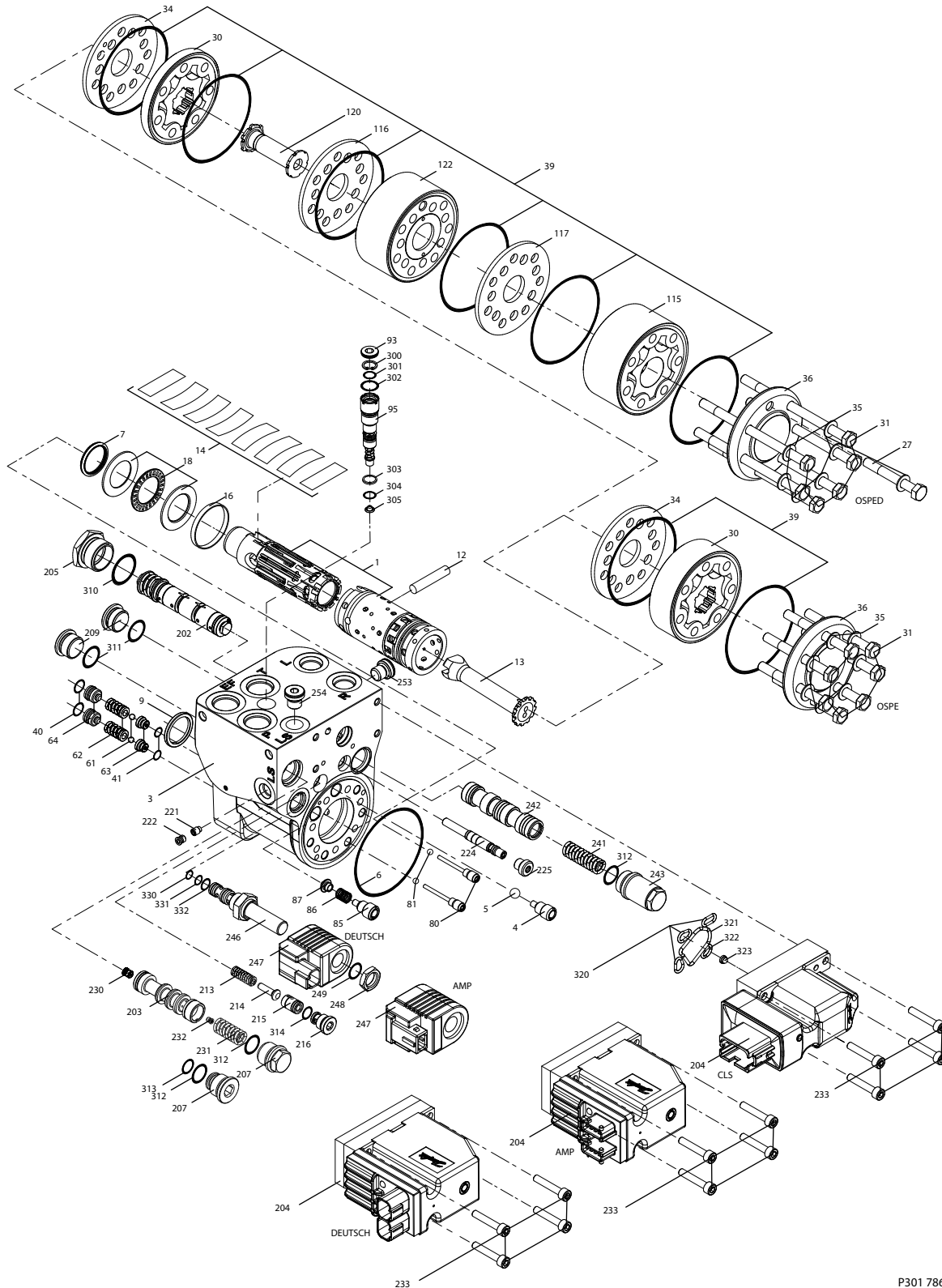

P301 786

Exploded View and Seal Kit
OSPE parts list
OSPE parts list

OSPE	Number per unit	Item	Tightening torque
Spool/Sleeve set	1	1	-
Housing	1	3	-
Screw	1	4	1.5 ±0.3 Nm
Ball for emergency steering Ø8.5 mm	1	5	-
O-ring Ø79.4 x Ø2.0 mm	1	6	-
Shaft seal	1	7	-
Dust seal ring	1	9	-
Cross pin	1	12	-
Cardan sharft	1	13	-
Set of springs	1	14	-
Ring	1	16	-
Bearing assembly	1	18	-
Gear set	1	30	-
Short screw (OSPED)	1	27	30 ±6 Nm
Screws (OSPED)	6	31	30 ±6 Nm
Screws (OSPE)	7	31	30 ±6 Nm
Valve plate	1	34	-
Washers	7	35	-
End cover	1	36	-
O-ring Ø79.4 x Ø2.0 mm (OSPED)	6	39	-
O-ring Ø79.4 x Ø2.0 mm (OSPE)	2	39	-
O-ring Ø9.0 x Ø1.5 mm	2	40	-
O-ring Ø6.0 x Ø1.5 mm	2	41	-
Balls for shock valves Ø4.8 mm	2	61	-
Spring with thrust pad for shock valves	2	62	-
Valves seats	2	63	5.5 ±0.5 Nm
Adjusting screws for shock valves	2	64	-
Pins	2	80	3 ±0.5 Nm
Balls for suction valves Ø4.8 mm	2	81	-
Screw	1	85	1.5 ±0.3 Nm
Spring	1	86	-
Valve cone for P check	1	87	-
Plug	1	93	-
Pilot relief valve cartridge	1	95	20 ±3 Nm
Gear set	1	115	-
Valve plate	1	116	-
Valve plate	1	117	-
Cardan shaft	1	120	-
Valve housing assembly	1	122	-
Spool, EH steering	1	202	-
Spool priority valve	1	203	-
PVE	1	204	-
Plug	1	205	45 ±5 Nm

Exploded View and Seal Kit
OSPE parts list (continued)

OSPE	Number per unit	Item	Tightening torque
Plug	1	207	45 ±5 Nm
Plugs	2	209	45 ±5 Nm
Spring	1	213	-
Cone pilot supply	1	214	-
Spool pilot supply	1	215	-
Plug	1	216	30 ±3 Nm
Check valve, LS	1	221	3.5 ±0.5 Nm
Orifice, LS	1	222	3.5 ±0.5 Nm
Spool pvfc	1	224	-
Plug	1	225	15 ±2 Nm
Orifice PP	1	230	3.5 ±0.5 Nm
Spring	1	231	-
Orifice Dynamic	1	232	1 ±0.1 Nm
Screws	4	233	8 ±1 Nm
Spring	1	241	-
Spool reaction/EH L&R cut off	1	242	-
Plug	1	243	45 ±5 Nm
Cartridge spool, pilot dump	1	246	15 ±2 Nm
Coil	1	247	-
Nut	1	248	5 ±1 Nm
O-ring Ø10.0 x Ø1.5 mm	1	249	-
Plug	1	253	20 ±3 Nm
Plug	1	254	20 ±3 Nm
Lock ring	1	300	-
O-ring Ø7.5 x Ø1.5 mm	1	301	-
O-ring Ø11.0 x Ø2.0 mm	1	302	-
Backup ring	1	303	-
O-ring Ø8.0 x Ø1.5 mm	1	304	-
Filter	1	305	-
O-ring Ø23.3 x Ø2.4 mm	1	310	-
O-ring Ø17.8 x Ø2.1 mm	2	311	-
O-ring Ø17.4 x Ø2.1 mm	2	312	-
O-ring Ø15.0 x Ø1.5 mm	1	313	-
O-ring Ø11.0 x Ø2.0 mm	1	314	-
O-ring Ø10.0 x Ø2.0 mm	3	320	-
O-ring Ø30.0 x Ø2.5 mm	1	321	-
O-ring Ø8.0 x Ø2.0 mm	1	322	-
Filter	1	323	-
O-ring ø7.65 x ø1.78 mm	1	330	-
O-ring ø9.25 x ø1.78 mm	1	331	-
O-ring ø13.5 x ø2.08 mm	1	332	-

Exploded View and Seal Kit
OSPE seal kit and spare parts

Spare parts list	Code No.	Item
Coil, Deutsch [®] : D08 12V DE 322113	11084688	247
Coil, AMP: D08 12V AJE 321930	11084690	247
Spare part bag containing: Cartridge spool for pilot dump, Nut and O-ring	11085713	246, 248, 249
Seal kit OSPE steering unit part	150N4041	6, 7, 9, 35, 39, 40, 41
Seal kit OSPE EH part	11160415	93, 225, 310, 311, 312, 313, 314
Seal kit Pilot relief valve cartridge	155L6870	300, 301, 302, 303, 304, 305
Seal kit PVE	157B4997	320, 321, 322, 323
Seal kit Cartridge spool for pilot dump	120433	330, 331, 332

Spare parts list	Code No.	Containing seal kits, codes
Seal kit KIT OSPE complete	11160838	150N4041, 11160415, 155L6870, 157B4997, 120433

Tools

Tools for OSPE

Tools

Holding tool for the entire steering valve.
 Material: Appropriate metal or hard plastic
 This tool is not available from Danfoss.

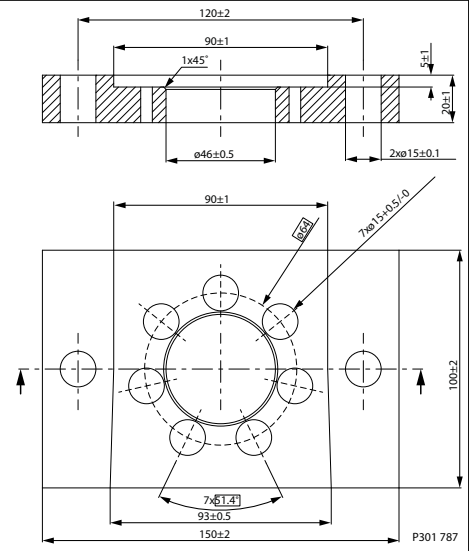

Assembly tool for dust seal.
 Material: Free cutting steel.
 This tool is not available from Danfoss.

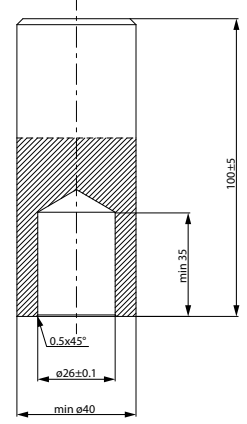

Assembly tool for shaft seal, O-ring/Roto Glyd type: Code number: 11092408.

This tool has been modified by January 2015. The upper end of outer tube has knurled surface on 25 mm from top only (was 35 mm). Tool with 35 mm knurled surface can be modified by grinding off 10 mm of the knurled surface.



Tools

Tools (continued)

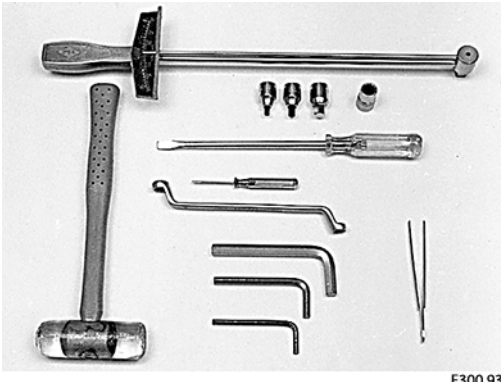
<p>Tool for removing/assembling pilot relief valve cartridge: Code number: 155L6494</p>	
<p>Torque wrench 0 - 70 Nm. 13 - 17 - 19 and 32 mm socket spanner. 2 - 2.75 - 3 - 4 - 5 - 6 and 8 mm Hex key. 12 mm screwdriver. 2 mm screwdriver. 13 - 17 - 19 - 7/8 inch mm ring spanner. Inside circlip pliers Plastic hammer. Tweezers. These tools are not available from Danfoss.</p>	 <p style="text-align: right;">F300 939</p>

Dismantling

Dismantling OSPE

Dismantling OSPE

Place the unit in the holding tool on steering column end.



F302 079

Screw out the 4 screws for the PVE (233) using a 5 mm  Hex key.
Remove the PVE (204).
O-rings (320, 321, 322) and filter (323) are fitted to the mounting surface of PVE.

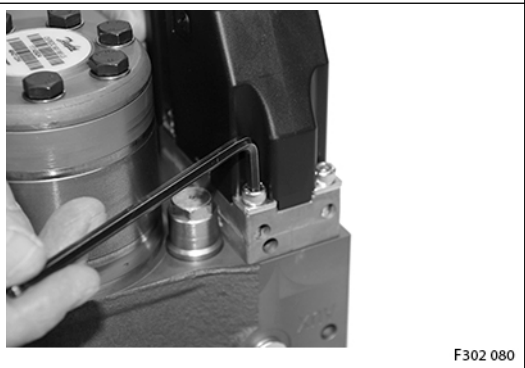

F302 080

Screw out the plug (243) using a 17 mm  socket or ring spanner.
O-ring (312) is fitted on plug (243).

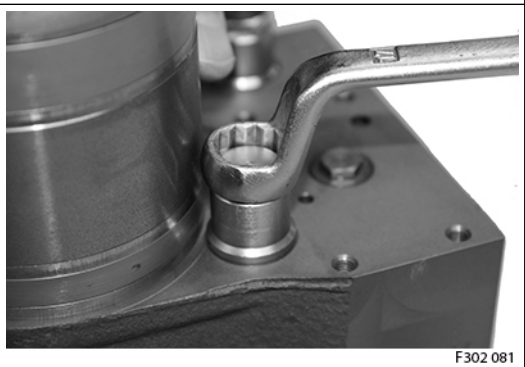

F302 081



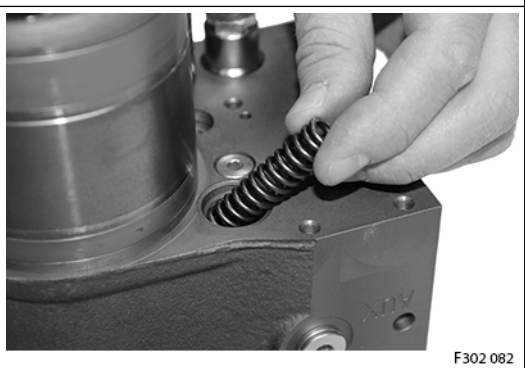

Remove the spring (241).



F302 082

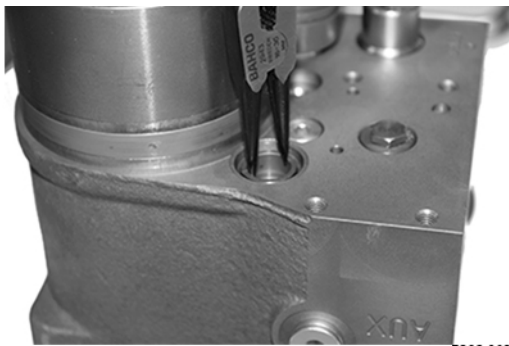

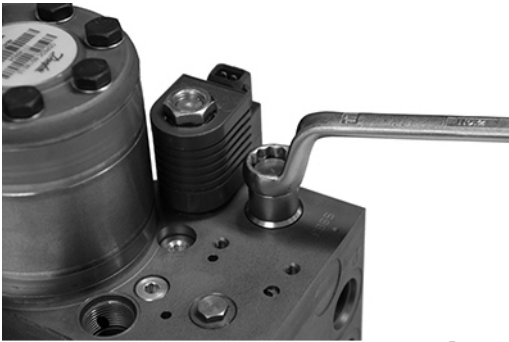



Dismantling

Dismantling OSPE (continued)

<p>Remove the EH L&R cut off spool (242).</p>	 <p>F302 083</p>
<p>Screw out the plug (207). If the OSPE is with priority valve integrated: Use a 17 mm  socket or ring spanner. O-ring (312) is fitted on plug (207). If the OSPE is without priority valve integrated: Use a 8 mm  Hex key. This plug is fitted with O-ring (312) and (313).</p>	 <p>F302 084</p>
<p>Remove the spring (231).</p>	 <p>F302 085</p>
<p>Remove the priority valve spool (203). Orifices (230) and (232) are screwed into spool (203).</p>	 <p>F302 086</p>

Dismantling

Dismantling OSPE (continued)

<p>Screw off the nut (248) using a 19 mm  socket or ring spanner.</p>	 <p style="text-align: right;">F302 087</p>
<p>Remove the O-ring (249).</p>	 <p style="text-align: right;">F302 088</p>
<p>Lift off the coil (247).</p>	 <p style="text-align: right;">F302 089</p>
<p>Screw out the cartridge spool (246) using a 7/8 inch  ring spanner. O-rings (330, 331, 332) are fitted on cartridge spool (246).</p>	 <p style="text-align: right;">F302 090</p>





Dismantling

Dismantling OSPE (continued)

<p>Replace the unit in the holding tool on the gear set end.</p> <p>Use appropriate support made of plastic, brass or aluminum under the mounting surface for the PVE to support the steering valve.</p>	 <p>F302 091</p>
<p>Screw out the adjusting screws for shock valves (64) using a 5 mm  Hex key. O-ring (40) is fitted on screw (64)</p>	 <p>F302 092</p>
<p>Remove the springs with trust pads for shock valves (62).</p>	 <p>F302 093</p>
<p>Remove the balls for shock valves (61).</p>	 <p>F302 094</p>

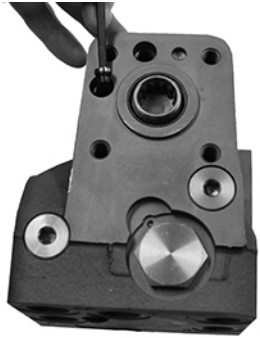

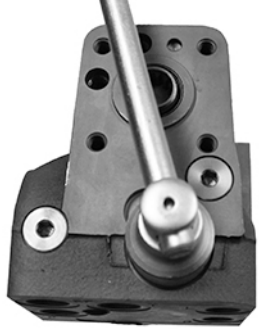
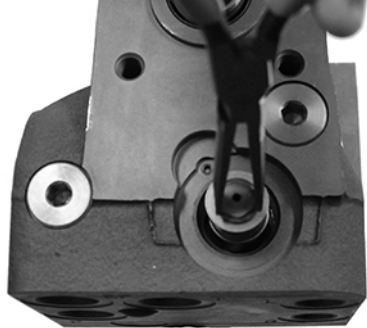
Dismantling

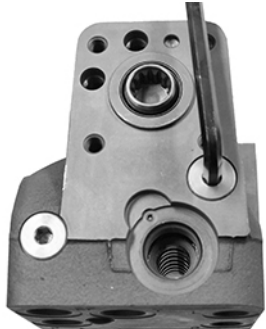
Dismantling OSPE (continued)

<p>Screw out the seats for shock valves (63) using a 2.75 mm  Hex key. O-ring (41) is fitted on seat (63).</p>	 <p style="text-align: right;">F302 095</p>
<p>Screw out the plug (205) using a 32 mm  socket spanner. O-ring (310) is fitted on plug (205).</p>	 <p style="text-align: right;">F302 096</p>
<p>Remove the EH-spool (202).</p>	 <p style="text-align: right;">F302 097</p>
<p>Screw out the plugs (209) using an 8 mm  Hex key. O-ring (311) is fitted on plug (209)</p> <p><u>The left side positioned plug is only present on OSPE's with priority valve integrated.</u></p>	 <p style="text-align: right;">F302 098</p>
<p>Replace the unit in the holding tool on steering column end.</p>	



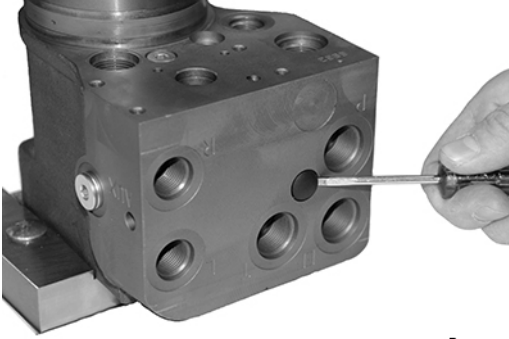
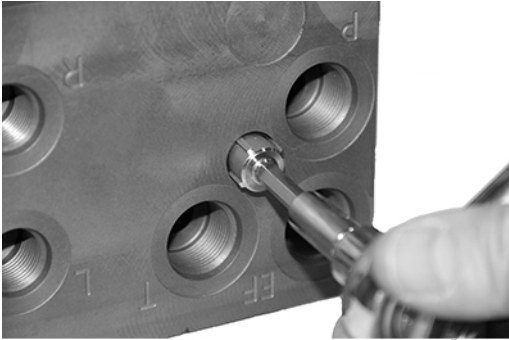
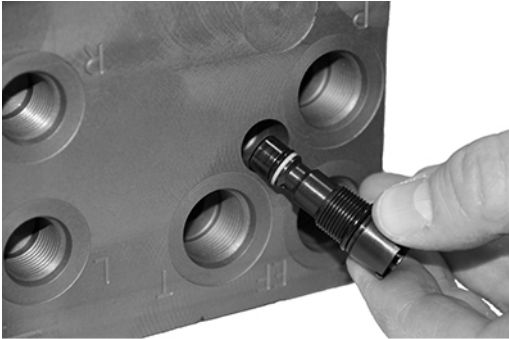

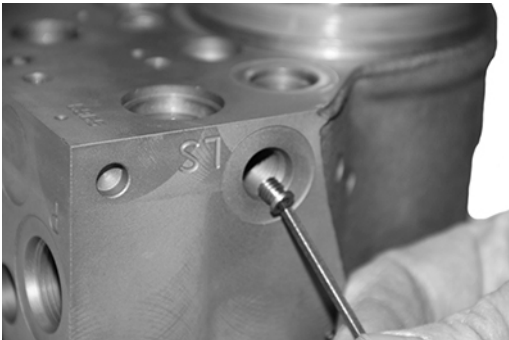

Dismantling

Dismantling OSPE (continued)

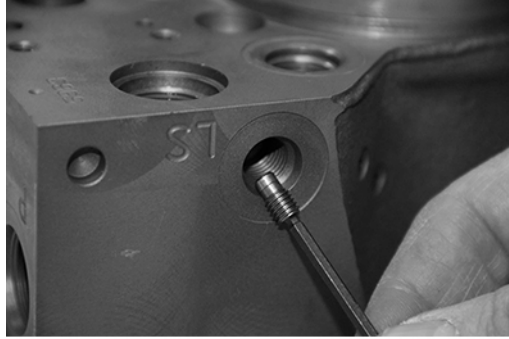
<p>Remove the plug (93) for the pilot relief valve (95)</p>	 <p>F302 099</p>
<p>Screw out the pilot relief valve cartridge (95) using special key Danfoss code 155L6494.</p>	 <p>F302 100</p>  <p>F302 101</p>
<p>Screw out the orifice (222) using a 3 mm  Hex key.</p> <p><u>This orifice is not present in all OSPE's.</u></p>	 <p>F302 102</p>

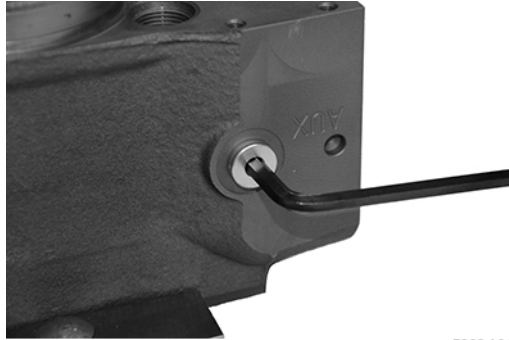
Dismantling

Dismantling OSPE (continued)

<p>Screw out the LS check valve (221) using a 3 mm  Hex key.</p> <p><u>This check valve is not present in all OSPE's.</u></p>	 <p>F301 103</p>
<p>Screw out the plugs (253) and (254) using a 6 mm  Hex key.</p> <p><u>These plugs not present in all OSPE's.</u></p>	 <p>F302 104</p>
<p>OSPED: Remove the screws (1x27 and 6x31) with washers (35) using a 13 mm  socket or ring spanner.</p> <p>OSPE: Has 7 identical screws (7x 31).</p>	 <p>F302 105</p>
<p>Remove the end cover (36), sideways.</p>	 <p>F302 106</p>



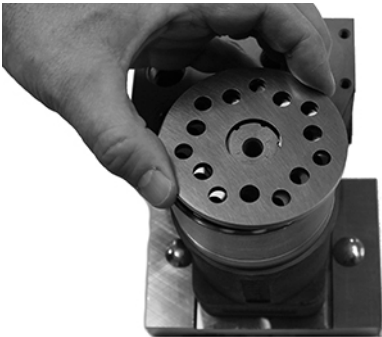
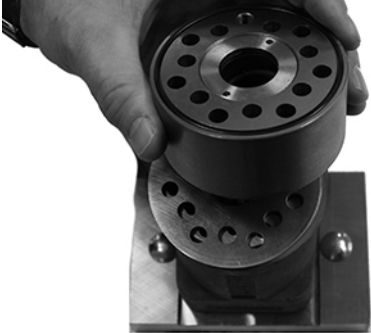
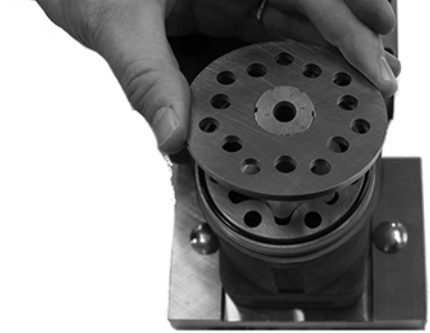

Dismantling

Dismantling OSPE (continued)

<p>OSPED: Lift the gearwheel set (115) off the unit. Remove the two O-rings (39).</p>	 <p>F302 107</p>
<p>OSPED: Remove the distributor plate (117).</p>	 <p>F302 108</p>
<p>OSPED: Remove valve housing assembly (122). Remove the two O-rings (39).</p> <p><u>Do not dismantle the entire valve (122).</u></p>	 <p>F302 109</p>
<p>OSPED: Remove the distributor plate (116).</p>	 <p>F302 110</p>

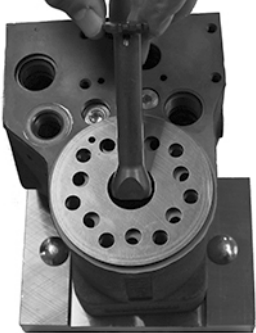

Dismantling

Dismantling OSPE (continued)

<p>OSPED: Remove the cardan shaft (120).</p>	 <p style="text-align: right;">F302 111</p>
<p>Lift the gearwheel set (30) off the unit. Remove the two O-rings (39).</p>	 <p style="text-align: right;">F302 112</p>
<p>Remove the cardan shaft (13).</p>	 <p style="text-align: right;">F302 113</p>
<p>Remove the distributor plate (34) from the housing.</p>	 <p style="text-align: right;">F302 114</p>

Dismantling

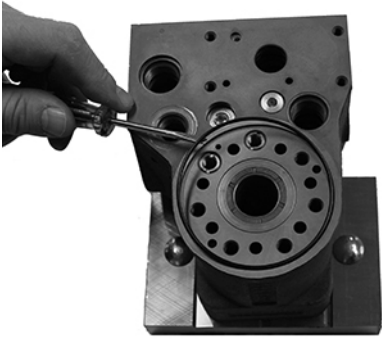
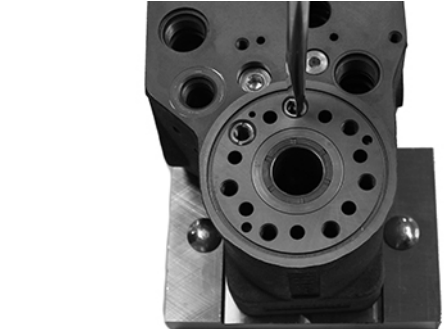
Dismantling OSPE (continued)

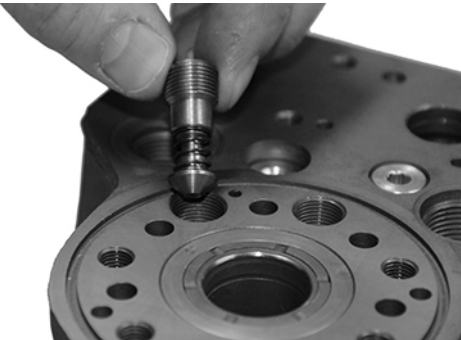
<p>Remove the O-ring (6) from housing.</p>	 <p>F302 115</p>
<p>Screw out threaded bushing/ball stop (4) from housing using a 12 mm screw driver and remove bushing from housing.</p>	 <p>F302 116</p>
<p>Screw out the screw (85) using a 12 mm screw driver. Spring (86) and valve cone (87) will be attached to the screw (85).</p>	 <p>F302 117</p>  <p>F302 118</p>

Dismantling

Dismantling OSPE (continued)

Screw out the pin bolts (80) using a 4 mm  Hex key.

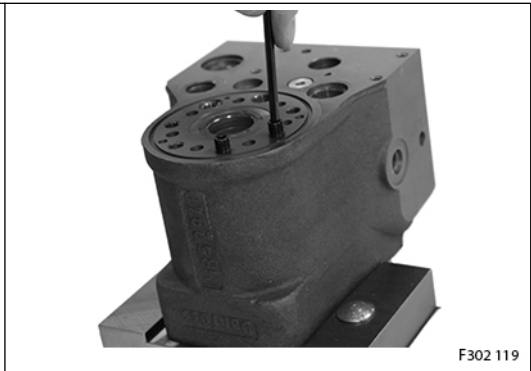

Screw out the plug (216) using a 6 mm  Hex key. O-ring 314 is fitted on plug (216).

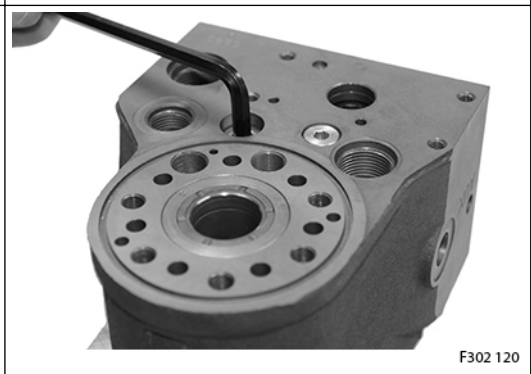

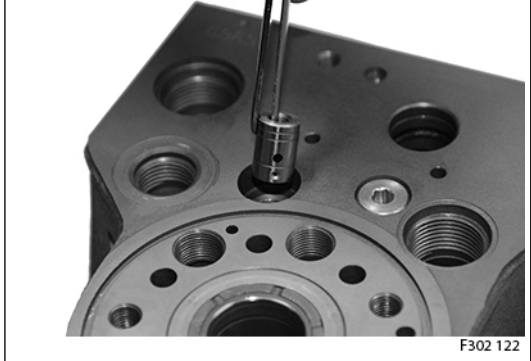

Remove plug (216) and spool (215).

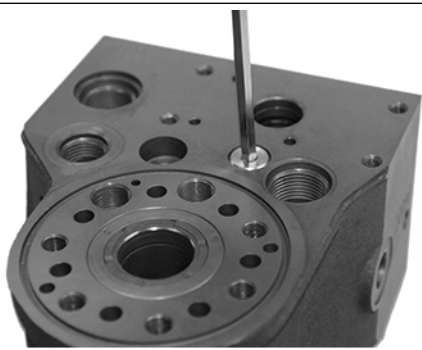

Dismantling

Dismantling OSPE (continued)

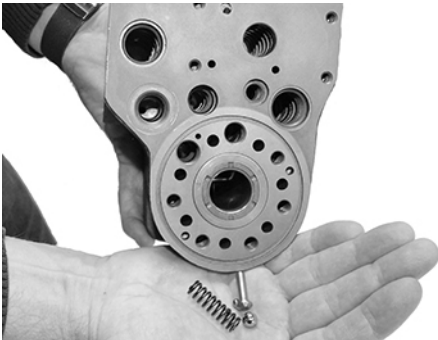
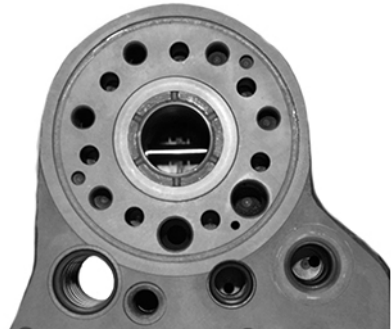
<p>Screw out the plug (225) using a 5 mm  Hex key.</p>	 <p>F302 123</p>
<p>Remove spool (224) using a 4 mm screw.</p>	 <p>F302 124</p>
<p>Shake out the check valve ball (5), suction valve balls (81), cone (214) and spring (213).</p>	 <p>F302 125</p>
<p>Place the housing with the ports facing down on the work bench. Ensure that the cross pin (12) in the spool and sleeve set (1) is in the horizontal position. The pin (12) can be observed through the open end of the spool.</p>	 <p>F302 126</p>

Dismantling

Dismantling OSPE (continued)

Press the spool (1) inwards (from the steering column end) and the sleeve (1), ring (16), neutral position springs (14) and bearing assembly (18) will be pushed out of the housing together.



F302 127

Take the bearing races with needle bearing (18) and the ring (16) off from the spool and sleeve set (1). The outer bearing (18) race can sometimes "stick" in the housing, therefore check that it has come out.



F302 128

Press out the cross pin (12).



F302 129



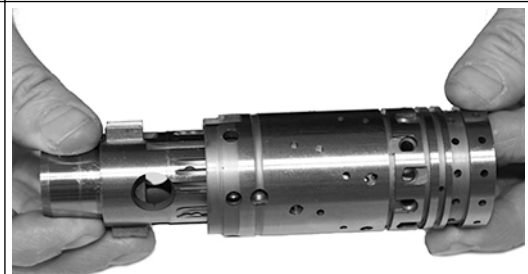

Carefully press the spool out of the sleeve.



F302 130

Dismantling

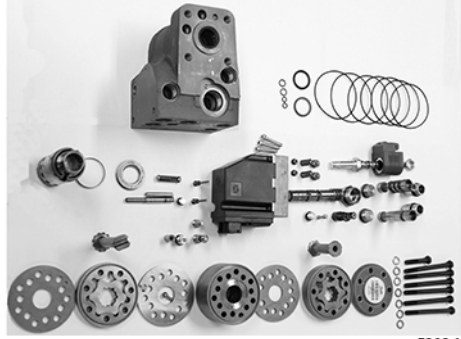
Dismantling OSPE (continued)

<p>Press the neutral position springs (14) out of the slot of the spool.</p>	 <p style="text-align: right;">F301 808</p>
<p>Remove dust seal (9) and shaft seal (Roto Glyd) (7) carefully with a screw driver or similar tool.</p>	 <p style="text-align: right;">F302 131</p>
<p>The steering unit OSPED is now completely dismantled</p>	 <p style="text-align: right;">F302 132</p>
<p>Cleaning Clean all parts carefully in Shellsol K or similar cleaner fluid.</p>	
<p>Inspection and replacement  Replace all seals and washers. Check all parts carefully and make any replacements as is necessary.</p>	

Assembly

Assembling OSPE

Assembling OSPE

Place the two flat neutral position springs (from item 14) in the slot of the spool (from item 1).
Place the curved springs between the flat ones and press them into place.



F301 810

Configuration of spring set (14).
There can be different numbers of curved springs depending on configuration of spring set.
There can be 2, 4 or 6 curved springs.

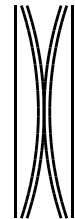

150-386.10

OSPEF: Spool and sleeve must be positioned correctly relatively to each other. Small marks are present on both spool and sleeve close to one of the slots for the spring set.

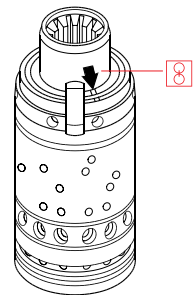

150-412.10



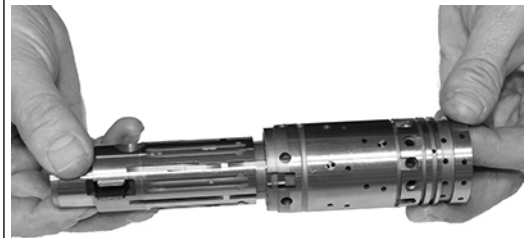

Guide the spool into the sleeve (1).
If the spool and sleeve has marks as shown above, these must be placed on same side.
Make sure the neutral position springs (14) are placed into the slot.



F302 133

Assembly

Assembling OSPE (continued)

<p>Line up the spring set (14).</p>	 <p>F301 812</p>
<p>Guide the ring (16) down over the sleeve. <u>The ring should be able to move free of the springs</u></p>	 <p>F302 134</p>
<p>Fit the cross pin (12) into the spool/sleeve set (1).</p>	 <p>F302 135</p>
<p>Fit bearing races and needle bearing (18) as shown on the drawing below.</p>	 <p>F301 815</p>



Assembly

Assembling OSPE (continued)

<p>! Caution</p> <p>Assembly pattern for standard bearing</p> <ol style="list-style-type: none"> 1. Outer bearing race 2. Needlebearing 3. Inner bearing race 4. Spool 5. Sleeve <hr/> <p>* The inside chamfer on the inner bearing race must face the chest of the inner spool.</p>	
<p>Place the steering valve housing with the port face down on the work bench. Guide the outer part of the assembly tool into the bore for the spool/sleeve set (1).</p>	
<p>Grease the shaft seal (Roto Glyd, 7) with hydraulic oil and place them on the tool. Ensure that the Roto Glyd seal is placed on the insertion tool as per the photograph.</p>	
<p>Hold the outer part of the assembly tool in the bottom of the steering unit housing and guide the inner part of the tool right to the bottom.</p>	

Assembly

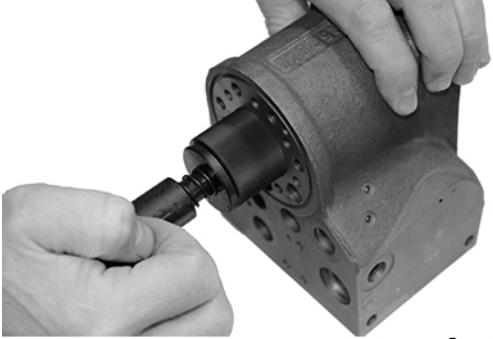
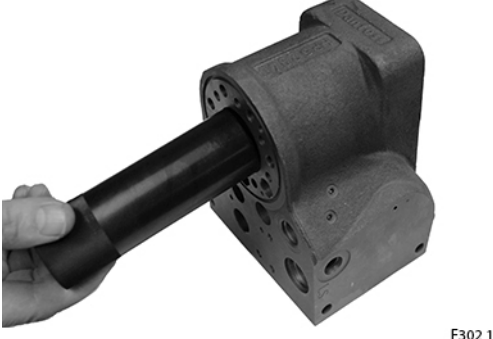
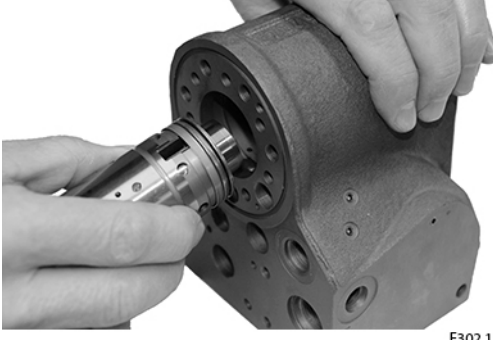
Assembling OSPE (continued)

<p>Press and turn the shaft seal (7) into position in the housing.</p>	 <p>F302 138</p>
<p>Draw the inner and outer parts of the assembly tool out of the steering unit bore, leaving the guide from the inner part in the bore.</p>	 <p>F302 136</p>
<p>With a light turning movement, guide the spool and sleeve into the bore.</p> <p><u>Fit the spool set holding the cross pin (12) horizontal.</u></p>	 <p>F302 139</p>
<p>The spool set will push out the assembly tool guide. The shaft seal (7) is now installed.</p>	 <p>F302 140</p>
<p>Place the steering valve housing (3) on the holding tool on the steering column end.</p>	

Assembly

Assembling OSPE (continued)

Put the check valve ball (5) into the hole indicated by the circle.



F302 141

Screw in the screw (4) using a 12 mm screw driver.  1.5 ± 0.3 Nm.



F302 142

Assemble spring (86) and cone (87) on screw (85). Place the assembly in the hole indicated by the circle.

Screw in the screw (85) using a 12 mm screw driver.  1.5 ± 0.3 Nm.

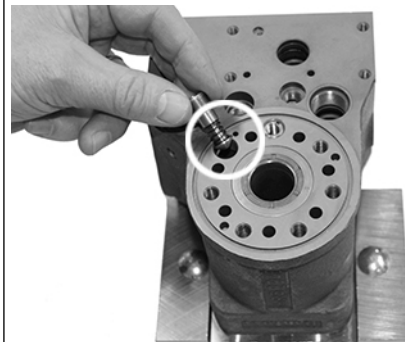

F302 143



Put the suction valve balls (81) into the holes indicated by the circles.



F302 144

Assembly

Assembling OSPE (continued)

Screw in the pin bolts (80) using a 4 mm  Hex key.  3 ± 0.5 Nm.

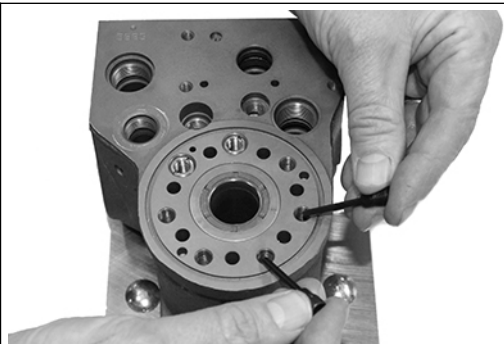

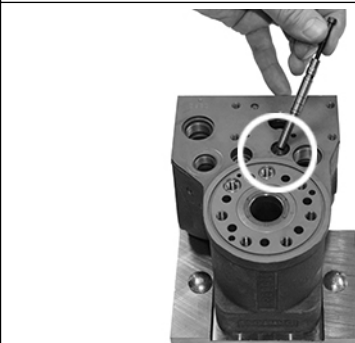

F302 145

Place the spool (224) in the hole indicated by the circle.



F302 146

Screw in the plug (225) using a 5 mm  Hex key.  10 ± 2 Nm

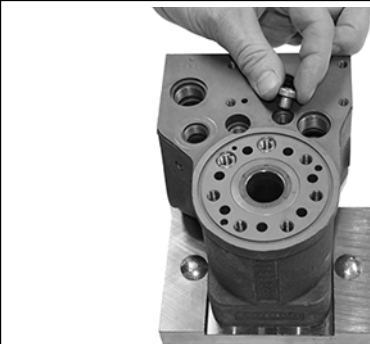

F302 147

Assembly

Assembling OSPE (continued)

Place the spring (213), cone (214) and spool (215) in the hole indicated by the circle.



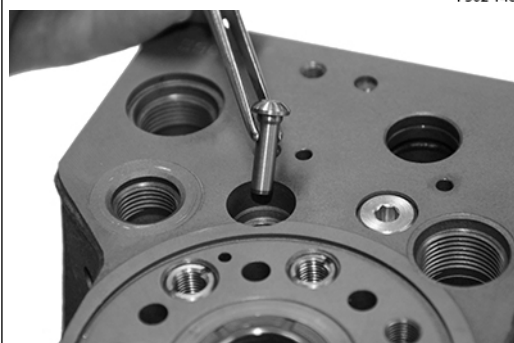

F302 148



F302 149



F302 150



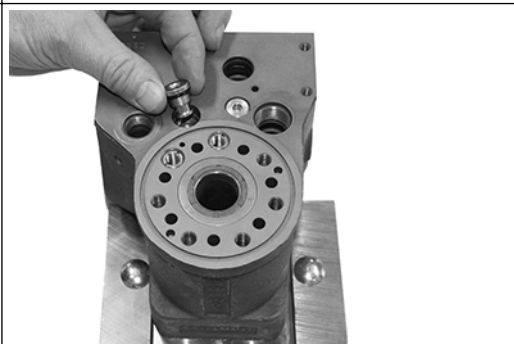

Place the O-ring (314) on plug (216). Screw in the plug (216) using a 6 mm  Hex key.  30 ± 3 Nm.

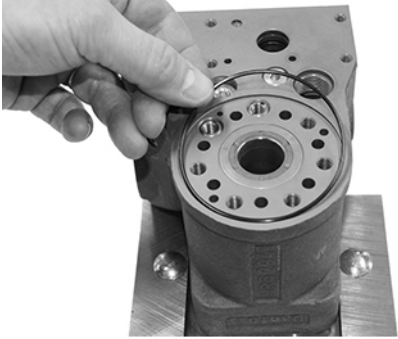

F302 151

Assembly

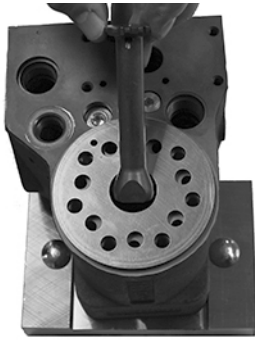
Assembling OSPE (continued)

<p>Insert the O-ring (6) in the groove on the housing.</p>	 <p>F302 152</p>
<p>Place the distributor plate (34). OSPED: the small $\varnothing 4$ mm hole of the plate (34) must be placed above the $\varnothing 3$ mm hole in the housing. The radial channel groove of the plate (34) must be facing the housing side.</p>	 <p>F302 153</p>
<p>Guide the cardan shaft (13) down into the bore so that the slot is parallel with the connection flange for P, T, L and R ports and lines up with the cross pin (12).</p>	 <p>F302 113</p>
<p>Place the 2 O-rings (39) in the two grooves in the gear rim. Fit the gearwheel with rim (30) on the cardan shaft (13). <u>Place the gear wheel side with all the deeper splines facing downwards. Only this side will fit on the cardan shaft due to all gear sets used in OSPE have timing securing: splines of gear wheel and cardan shaft can only be assembled with correct timing.</u></p>	 <p>F302 112</p>

Assembly

Assembling OSPE (continued)

OSPED: Place and rotate the cardan shaft (120) with the big diameter end until it moves in gear with gear wheel of gear set (30).

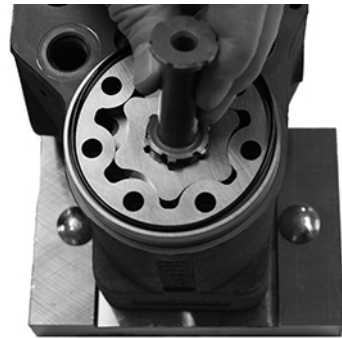

F302 111

OSPED: Place the middle distributor plate (116) so that the channel holes match the holes in the gear set.

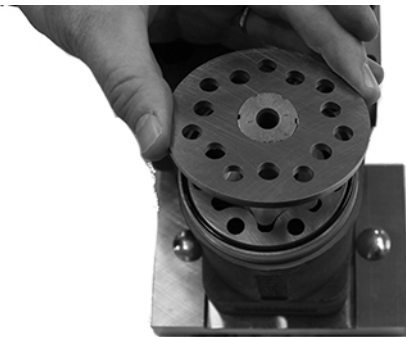

F302 110

OSPED: Place the 2 O-rings (39) in the two grooves in the valve housing assembly (122). Place the valve housing assembly so that the one and only M8 thread whole points upwards and direction port face for P, T, L and R connections.



F302 173







Make sure that channel holes of the valve housing assembly (122) match the holes in the distributor plate (116).



F301 827







Assembly

Assembling OSPE (continued)

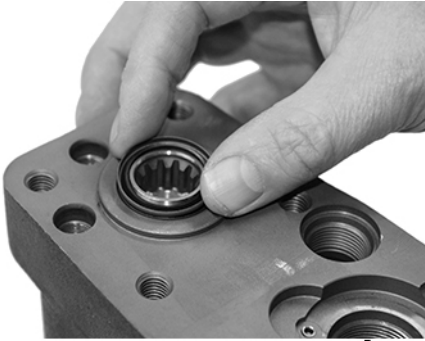
<p>OSPED: Place the rear distributor plate (117) so that the channel holes match the holes in valve housing assembly (122).</p>	 <p style="text-align: right;">F301 828</p>
<p>OSPED: Place the 2 O-rings (39) in the two grooves in the gear rim. Fit the gearwheel with rim (115) on the cardan shaft (120). Place the gear wheel side with all the deeper splines facing downwards. Only this side will fit on the cardan shaft due to all gear sets used in OSPE have timing securing: splines of gear wheel and cardan shaft can only be assembled with correct timing.</p>	 <p style="text-align: right;">F302 107</p>
<p>Place the end cover (36) in position. Ensure that the bar codes and writing are parallel with the port face for P, T, L and R connections.</p>	 <p style="text-align: right;">F302 154</p>
<p>OSPED: Fit the short screw (27) with washer (35) and place it in the hole indicated by circle. OSPED: Fit the six screws (31) with new washers (35) and insert them. Cross-tighten all the screws (27 and 31) using a 13 mm  socket spanner.  30 ±6 Nm. OSPE: Has 7 identical screws (7x 31).</p>	 <p style="text-align: right;">F302 155</p>
<p>Replace the unit in the holding tool on gear set end. Use appropriate support under the mounting surface for the PVE to support the steering valve.</p>	



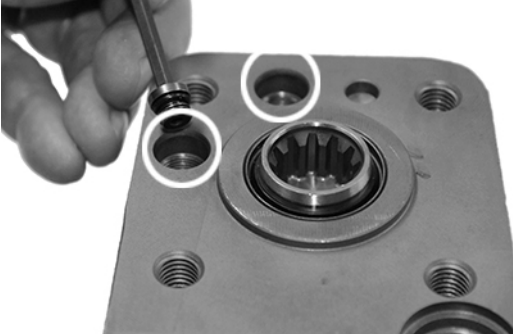



Assembly

Assembling OSPE (continued)

<p>The OSPE can now be function tested manually: it must be possible to rotate input shaft with torque < 3.5 Nm [31 lbf·in].</p>	
<p>Place the dust seal ring (9) in the housing.</p>	 <p>F302 156</p>
<p>Fit the dust seal ring (9) in the housing using special tool for dust seal assembly (see page 7) and a plastic hammer.</p>	 <p>F302 157</p>
<p>Place O-ring (41) on the shock valve seats (63). Screw in the seats (63) using a 2.75 mm  Hex key into the cavities indicated by the circles.  6 ± 1 Nm. [53.1 \pm 8.85 lbf·in].</p>	 <p>F302 158</p>
<p>Place one ball (61) in each of the shock valve cavities.</p>	 <p>F302 159</p>

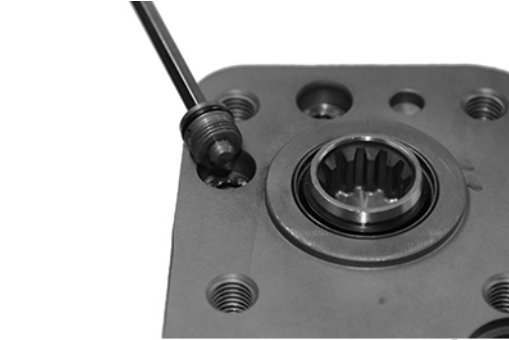
Assembly

Assembling OSPE (continued)

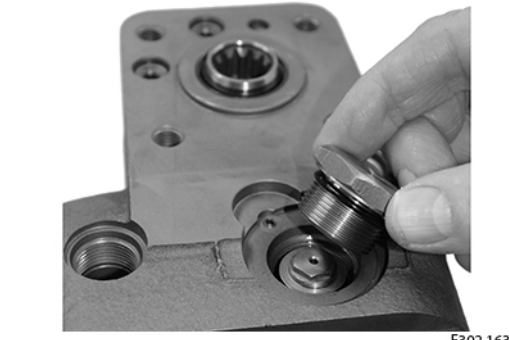
<p>Place springs with trust pads (62) over the two balls.</p>	 <p>F302 160</p>
<p>Place O-rings (40) on adjusting screws (64). Screw in the two adjusting screws (64) using a 5 mm  Hex key. After entire assembly of the steering valve, make the pressure setting on a test panel according to valve setting specification, see Shock valves on page 44.</p>	 <p>F302 161</p>
<p>Insert the EH-spool (202).</p>	 <p>F302 162</p>
<p>Place O-ring (310) on plug (205). Screw in the plug (205) using a 32 mm  socket spanner.  45 ±5 Nm</p>	 <p>F302 163</p>

Assembly

Assembling OSPE (continued)

Place O-rings (311) on plugs (209). Screw in the plugs (209) using a 8 mm Hex key. 45 ±5 Nm

The left side positioned plug is only present on OSPE's with priority valve integrated.

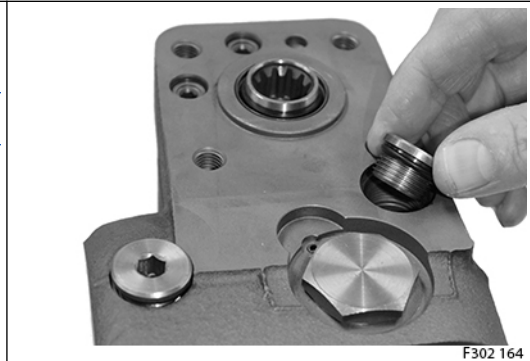

F302 164

Replace the unit in the holding tool on steering column end.

Place back up ring (303), O-rings (301, 302, 304), filter (305) and locking ring (300) in/on cartridge (95). Screw in cartridge (95) using special key Danfoss code 155L6494.

20 ±3 Nm.

After entire assembly of the steering valve, make the pressure setting on a test panel according to valve setting specification, see *Shock valves* on page 44. Insert plastic protection plug (93).

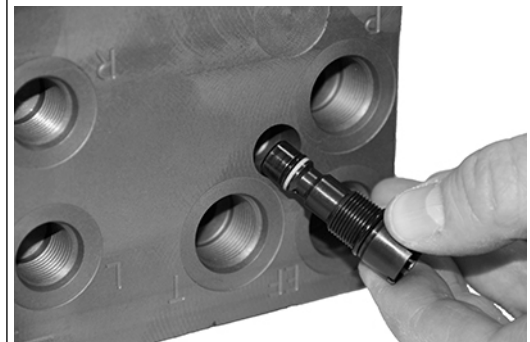

F302 101

Screw in the LS check valve (221) using a 3 mm Hex key. 3 ±0.5 Nm.

This check valve is not present in all OSPE's.

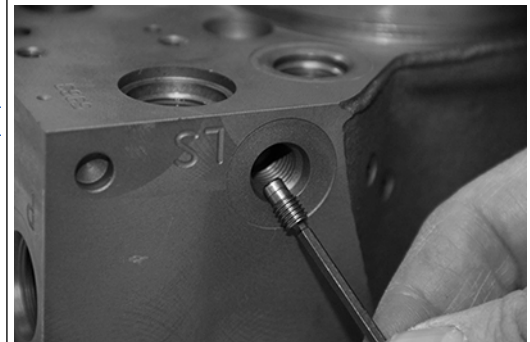

F301 103

Screw in the orifice (222) using a 3 mm Hex key. 3 ±0.5 Nm.

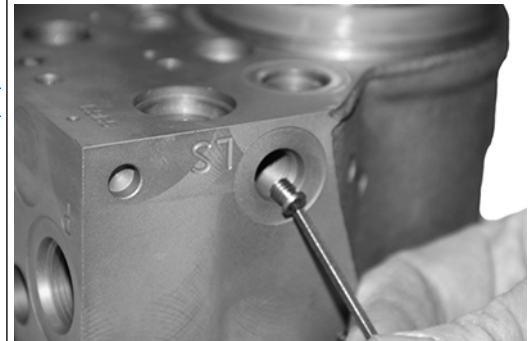

This orifice is not present in all OSPE's.



F302 102

Assembly

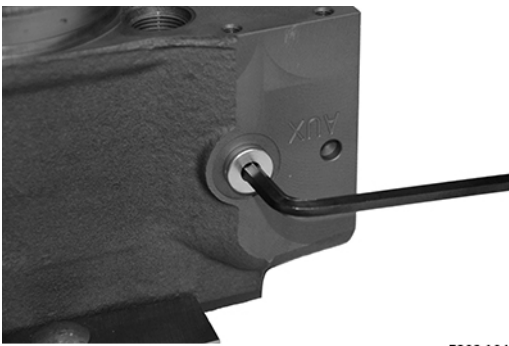
Assembling OSPE (continued)

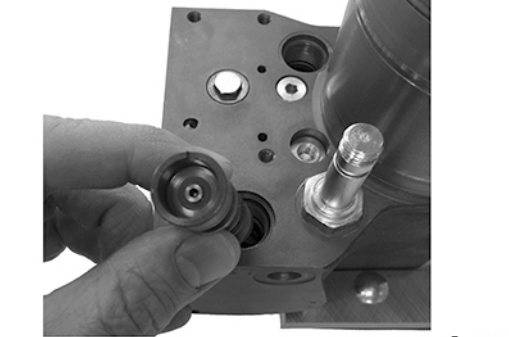
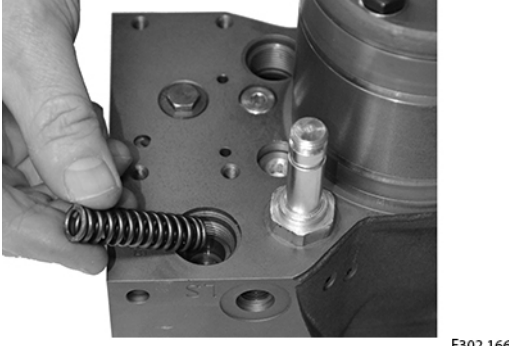
<p>Screw in the plugs (253) and (254) using a 6 mm Hex key. 20 ±3 Nm.</p> <p><u>These plugs not present in all OSPE's.</u></p>	 <p style="text-align: right;">F302 104</p>
<p>Place O-rings (330, 331, 332) on cartridge spool (246). Screw in the cartridge spool (246) using a 7/8 inch ring spanner. 15 ±2 Nm.</p>	 <p style="text-align: right;">F302 090</p>
<p>OSPE with priority valve: Assemble spool (203) with the PP orifice (230) using a 3 mm Hex key. 3.5 ±0.5 Nm. And with dynamic orifice (232) using a 2 mm Hex key. 1 ±0.1 Nm. Insert the priority valve spool (203) with the spring bore pointing outwards.</p>	 <p style="text-align: right;">F302 165</p>
<p>OSPE with priority valve: Insert the spring (231). Dimension of this spring depends on specification of priority valve.</p>	 <p style="text-align: right;">F302 166</p>

Assembly

Assembling OSPE (continued)

OSPE with priority valve:
Place the O-ring (312) on plug (207 with 17 mm key profile).
Screw in the plug (207) using a 17 mm socket spanner 45 ±5 Nm.

OSPE without priority valve:
Place the O-rings (312, 313) on plug (207 with 8 mm Hex key profile).
Screw in the plug (207) using a 8 mm Hex key.
 45 ±5 Nm.

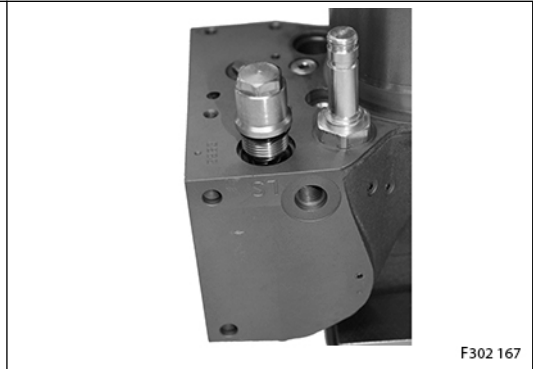

Insert the EH L&R cut off spool (242) with the spring bore pointing outwards.

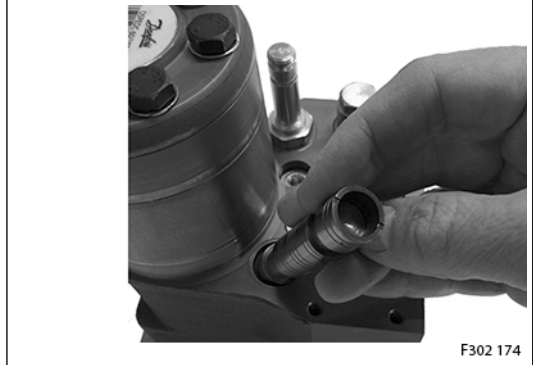

Insert the spring (241). Dimension of this spring: Wire diameter: 2.2 mm Length: 50.2 ±0.8 mm





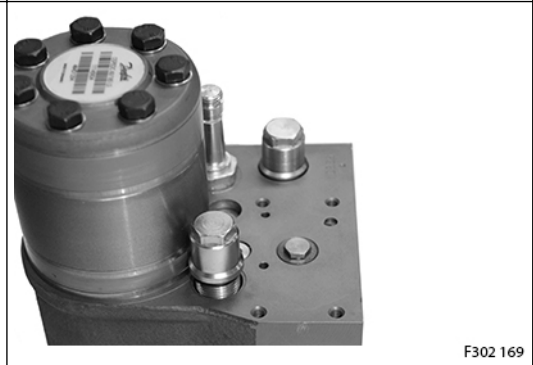



Place the O-ring (312) on plug (243). Screw in the plug (243) using a 17 mm socket spanner 45 ±5 Nm.

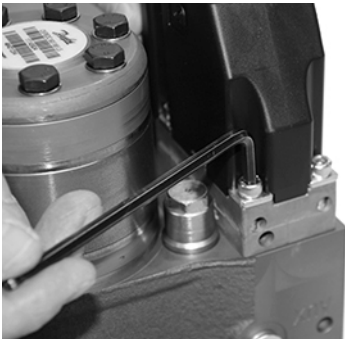

Assembly

Assembling OSPE (continued)

<p>Check proper movement of EH spool (202): press on spool end, the spool must be able to be moved downwards 4 mm with force < 100N, and it must be able to return to starting position by help of the neutral spring package integrated in the spool end facing plug (205).</p>	 <p>F302 170</p>
<p>Place O-rings (320, 321, 322) and filter (323) on PVE (204). Place the PVE (204) on OSPE housing as illustrated and screw in the 4 screws for the PVE (233) using a 5 mm  Hex key.  8 ± 1 Nm.</p>	 <p>F302 080</p>
<p>Place coil 247 on cartridge for pilot dump (246). Place O-ring (249) and nut (248) on cartridge for pilot dump (246). Screw in the nut (248) using a 19 mm  socket spanner  5 ± 1 Nm.</p>	 <p>F302 171</p>
<p>Make test and valve setting according to description, see Steering test on page 43.</p>	
<p>Screw in the plastic plugs into the connection ports to keep the ports clean during storage and transportation.</p>	 <p>F302 172</p>

Test and valve setting of OSPE

This section describes minimum tests needed, when the OSPE steering valve has been disassembled and reassembled.

OSPEDC LSRM with integrated priority valve:

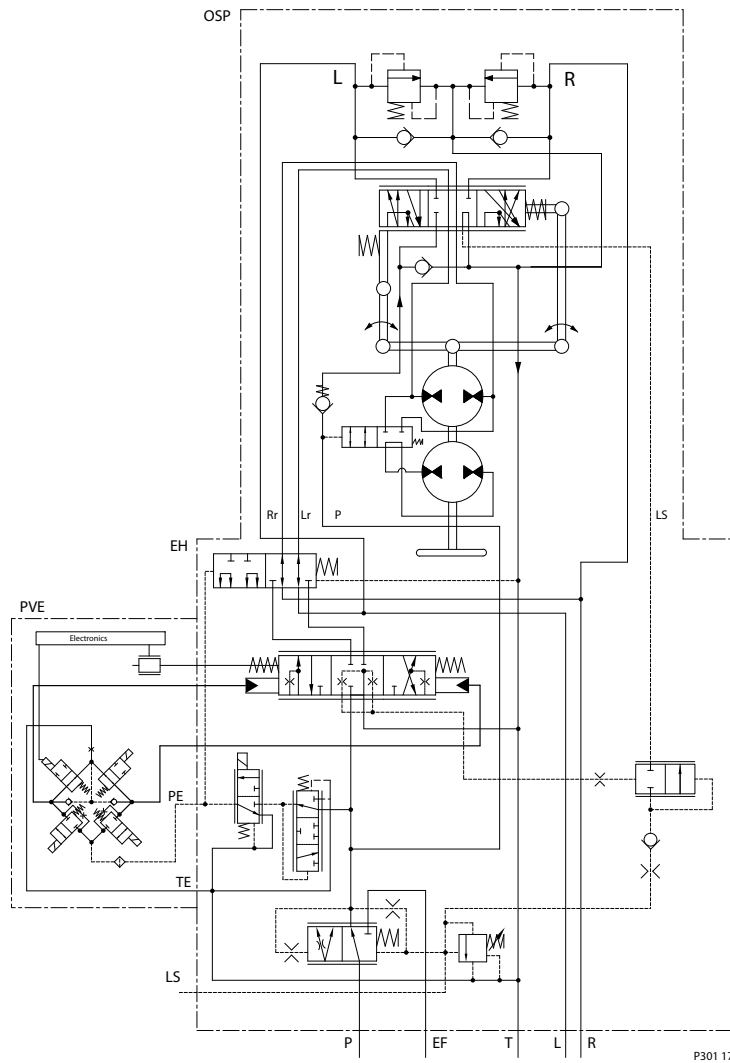

Set up for testing

A universal hydraulic work bench is required for this setup. The work bench must support the following pump capacity.

- 25 l/min and up to 210 bar pressure for relief valve setting and steering test
- 3 l/min and up to 280 bar pressure for shock valve setting

The hydraulic oil must have a viscosity of 21 cSt. at 50°C with a maximum degree of contamination according to ISO 4406: 21/19/16.

Set up OSPE with integrated priority valve

1. Connect double rod cylinder to L and R ports of OSPE.
2. Connect pressure gauges to all ports of OSPE.
3. Connect steering column and steering wheel to the input shaft of the OSPE.

Test and valve setting of OSPE

4. If OSPE with PVES, PVED CC, or PVED CL, connect battery power cables with on/off switch to the coil of control valve for mode select (247).

Voltage must meet the specification for the code.

[For OSPE with PVED CLS, the coil \(247\) is controlled by the PVED CLS.](#)

5. Connect voltage supply and signal input for the PVE.
6. Connect P port to pump supply.
7. Block LS port with steel plug.
8. Connect T and EF ports separately to tank of pump station.

T pressure should not exceed ~5 bar. The maximum allowed T pressure is 25 bar.

The pump supply circuit should not exceed 210 bar P-T.

9. Screw the adjusting screws of shock valves to block.
Screw clockwise as much as possible to a torque < 5 Nm to ensure the shock valves do not open during steering test or setting of pilot relief valve.

Set up OSPE without integrated priority valve

1. Connect double rod cylinder to L and R ports of OSPE.
2. Connect pressure gauges to all ports of OSPE.
3. Connect steering column and steering wheel to the input shaft of the OSPE.
4. If OSPE with PVES, PVED CC, or PVED CL, connect battery power cables with on/off switch to the coil of control valve for mode select (247).

Voltage must meet the specification for the code.

[For OSPE with PVED CLS, the coil \(247\) is controlled by the PVED CLS.](#)

5. Connect voltage supply and signal input for the PVE.
6. Connect an external priority valve between P of pump station and P of OSPE.
Use Danfoss priority valve OLS 80 code 152B8269, or other OLS 80 with same orifice and spring specification.

Dynamic orifice: Ø1,0 mm

LS orifice: Ø1,2 mm

Spring: 7 bar

7. Connect LS port of OSPE with LS port of OLS.
8. Connect T port of OSPE to tank.
9. Screw the adjusting screws of shock valves to block.
Screw clockwise as much as possible to a torque < 5 Nm to ensure the shock valves do not open during steering test or setting of pilot relief valve.

Steering test

During the testing no motor effect, disturbing vibrations, noise, sticking or other irregularities must occur.

1. Start the pump, the pump flow is adjusted to approx. 25 l/min and pump pressure control must be set to app. 70 bar.
2. Let the supplied oil flow through the steering unit for a few minutes. At the same time the steering wheel is to be rotated a few times in both directions to bleed of air from the unit and the system.
3. Operate the steering wheel by approx. 10 rpm in a smooth manner from end stroke to end stroke of the steering cylinder for at least 5 cycles. Make sure pressure P-T, 70 bar can be achieved, when steering against end stroke. If this is not possible, the adjusting screw of the pilot relief valve (item 95 of exploded view) must be turned clockwise until P-T, 70 bar is achievable.

Test and valve setting of OSPE

Pilot relief valve

The pump flow is adjusted to approx. 25 l/min and pressure to max 210 bar.

The steering wheel is actuated until the steering cylinder reaches one of its end strokes and the steering wheel is actuated in this cylinder position with steering torque 25 ± 5 Nm.

The pilot relief valve (item 95 of exploded view) is set according to specification: Maximum steering pressure (P-T), bar, for the code in question.

The setting pressure is the pressure on the P-port minus the T-port of OSPE.

Neutral positioning test, OSP part

After adjusting the pilot relief valve, the steering wheel must be able to go to neutral position by itself no later than ~1 second after the activation of the steering wheel has been stopped.

The steering unit is in neutral position when the pressure drop (P-T) is no higher than 18 bar.

Neutral positioning test, EH part

For OSPE with PVES, PVED CC, PVED CL: Apply battery power to the coil (item 247 on exploded view). Apply battery power and input signal to the PVE: observe that the steering cylinder is moving according to direction of input signal for PVE. Apply neutral position signal for PVE, observe that cylinder movement stops and that pressure LS-T drops to max. 10 bar.

For OSPE with PVED CLS: The coil (item 247 of exploded view) is controlled by the PVED CLS.

Manual steering

Without pressure on P and T ports, the unit must be able to steer in a smooth manner to the right and to the left observed by the cylinder movement.

For OSPED: the number of turns on the steering wheel for moving the steering cylinder from lock to lock, must increase in comparison to do this test with normal pump supply. Without pump supply the number of turns must match cylinder volume/emergency steer displacement of OSPED. Example: Cylinder volume: 600 ccm, and OSPED 60/185 LSRM > Number of turns must be $600/60 \approx 10$ turns.

Shock valves

Remove pump supply to P port of OSPE and plug the P-port. Remove the steering cylinder connection. T must still be connected to tank of pump station.

OSPE LSRM

L and R ports are connected through the spool/sleeve set in neutral, steering wheel must be untouched during setting of shock valves:

1. Plug the L- port and apply pump pressure to the R-port. The shock valves are to be set at an oil flow of 3 l/min. The supply must be limited to max 280 bar on the pump station.
2. Screw one of the shock valves (item 64) outwards until pressure is reduced to the lower specified value + 15-20 bar and flows comes out of the T-port (e.g. 235-240 bar of specified value 220-240 bar)
3. Screw the other shock valve (item 64) outwards until pressure is reduced to the lower specified value + 0-5 bar and check that flow out of T-port continues (e.g. 220-225 bar of specified value 220-240 bar).

OSPE LS (non reaction/non reaction versions)

The shock valves are to be set at an oil flow of 3 l/min applied to one of the servo ports L and R at a time. The supply must be limited to maximum 280 bar on the pump station.

Test and valve setting of OSPE

Adjust the pressure (R-T/L-T) by adjusting screws of shock valves (item 64) to the specified value for the shock valve setting for the code in question.

Check for external leakage

After testing of the former items, the steering column (wheel) and port connections are removed. P, L, R, EF and LS ports are to be plugged and oil pressure of 20 bar is supplied to the T port for approx. 3 minutes: No leakage must be found in any assemblies or at the input shaft for the steering column.

Tightening Torques
Tightening torques for connections OPSE

Tightening Torques for Connections OSPD V2

Connections	Maximum tightening torque Nm [lbf.in]			
	With cutting edge	With copper washer	With alum. Washer	O-ring
M12 • 1.5	30 [265]	20 [177]	30 [265]	25 [221]
M18 • 1.5	80 [708]	55 [486]	70 [619]	50 [442]
M22 • 1.5	100 [885]	65 [575]	80 [708]	60 [531]



Products we offer:

- Bent Axis Motors
- Closed Circuit Axial Piston Pumps and Motors
- Displays
- Electrohydraulic Power Steering
- Electrohydraulics
- Hydraulic Power Steering
- Integrated Systems
- Joysticks and Control Handles
- Microcontrollers and Software
- Open Circuit Axial Piston Pumps
- Orbital Motors
- PLUS+1® GUIDE
- Proportional Valves
- Sensors
- Steering
- Transit Mixer Drives

Danfoss Power Solutions is a global manufacturer and supplier of high-quality hydraulic and electronic components. We specialize in providing state-of-the-art technology and solutions that excel in the harsh operating conditions of the mobile off-highway market. Building on our extensive applications expertise, we work closely with our customers to ensure exceptional performance for a broad range of off-highway vehicles.

We help OEMs around the world speed up system development, reduce costs and bring vehicles to market faster.

Danfoss – Your Strongest Partner in Mobile Hydraulics.

Go to www.powersolutions.danfoss.com for further product information.

Wherever off-highway vehicles are at work, so is Danfoss. We offer expert worldwide support for our customers, ensuring the best possible solutions for outstanding performance. And with an extensive network of Global Service Partners, we also provide comprehensive global service for all of our components.

Please contact the Danfoss Power Solution representative nearest you.

Comatrol

www.comatrol.com

Schwarzmueller-Inverter

www.schwarzmueller-inverter.com

Turola

www.turolaocg.com

Hydro-Gear

www.hydro-gear.com

Daikin-Sauer-Danfoss

www.daikin-sauer-danfoss.com

Local address:

Danfoss Power Solutions (US) Company
2800 East 13th Street
Ames, IA 50010, USA
Phone: +1 515 239 6000

Danfoss Power Solutions GmbH & Co. OHG
Krokamp 35
D-24539 Neumünster, Germany
Phone: +49 4321 871 0

Danfoss Power Solutions ApS
Nordborgvej 81
DK-6430 Nordborg, Denmark
Phone: +45 7488 2222

Danfoss Power Solutions Trading (Shanghai) Co., Ltd.
Building #22, No. 1000 Jin Hai Rd
Jin Qiao, Pudong New District
Shanghai, China 201206
Phone: +86 21 3418 5200

Danfoss can accept no responsibility for possible errors in catalogues, brochures and other printed material. Danfoss reserves the right to alter its products without notice. This also applies to products already on order provided that such alterations can be made without changes being necessary in specifications already agreed. All trademarks in this material are property of the respective companies. Danfoss and the Danfoss logotype are trademarks of Danfoss A/S. All rights reserved.