

Technical Information
OMSU Series 3 Orbital Motor

Contents

Chapter 1: Code numbers.....	5
OMSU Series 3 code numbers.....	6
Chapter 2: Dimensions.....	9
OMSU dimensions.....	10
Chapter 3: Connection dimensions, attached component	11
Chapter 4: Internal spline data for the component to be attached.....	13
Material:	14
Hardening specification:	14
Chapter 5: General data.....	17
Drain connection on OMSU or attached component	18
Installing OMSU.....	18
Mounting.....	18
Direction of rotation.....	19
Maximum tightening torque	19
Checking OMSU.....	19
Exploded view OMSU.....	20
OMSU spare parts list	21

Chapter

1

Code numbers

Topics:

- *OMSU Series 3 code numbers*

OMSU Series 3 code numbers

Table 1: Ultra-short motor

Without output shaft	OMSU 80	OMSU 100	OMSU 125	OMSU 160	OMSU 200	OMSU 250	OMSU 315	OMSU 400
	151F0578	151F0579	151F0580	151F0581	151F0582	151F0583		(*)

Table 2: Technical data

Motor size			OMSU 80	OMSU 100	OMSU 125	OMSU 160	OMSU 200	OMSU 250	OMSU 315	OMSU 400
Geometrical displacement	cm ³		80.5	100	125.7	159.7	200	250	314.9	393
Max. speed	min ⁻¹	cont.	810	750	600	470	375	300	240	190
		int.	1000	900	720	560	450	360	285	230
Max. torque	daNm	cont.	20	25	32	36	46	50	63	67
		int. ⁽¹⁾	24	30	38	48	60	63	79	79
		peak	26	32	40	51	65	72	90	98
Max. output	kW	cont.	16	17.5	17.5	16	14	12.5	11.5	10.5
		int. ⁽¹⁾	19	21	21	21	17.5	15	13.5	12.5
Max. pressure drop	bar	cont.	175	175	175	160	160	140	140	120
		int. ⁽¹⁾	210	210	210	210	210	175	175	140
		peak ⁽²⁾	225	225	225	225	225	200	200	175
Max. oil flow	l/min	cont.	65	75	75	75	75	75	75	75
		int. ⁽¹⁾	80	90	90	90	90	90	90	90
Max. starting pressure with unloaded shaft	bar		12	10	10	8	8	8	8	8

(*) Please contact the sales Organization for the code numbers of these motors.

(1) Intermittent operation: permissible values may occur for max. 10% of every minute.

(2) Peak load: permissible values may occur for max. 1% of every minute.

Motor size			OMSU 80	OMSU 100	OMSU 125	OMSU 160	OMSU 200	OMSU 250	OMSU 315	OMSU 400
Min. starting torque	daNm	at max pressure cont.	15.5	19.5	24.5	28.5	35.5	39	49	53
		At max. pressure int. ⁽¹⁾	19	23.5	30	37.5	47	49	61	61
Min. speed	min ⁻¹		10	10	8	8	6	6	5	5
Max. Inlet pressure	bar	cont.	210	210	210	210	210	210	210	210
		Int. ⁽¹⁾	250	250	250	250	250	250	250	250
		peak ⁽²⁾)	300	300	300	300	300	300	300	300
Max. return pressure with drain line	bar	cont.	140	140	140	140	140	140	140	140
		Int. ⁽¹⁾	175	175	175	175	175	175	175	175
		peak ⁽²⁾)	210	210	210	210	210	210	210	210

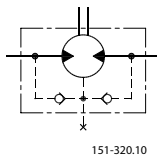

OMSU motors have built-in check valves.

⁽³⁾ At speeds lower than those given, the motor cannot be expected to run evenly.

⁽⁴⁾ If no drain line is fitted, the built-in check valves ensure that the case pressure is equal to the pressure in the return line. The max. case pressure for OMSU is dictated by the technical data of the component to be attached.

Chapter

2

Dimensions

Topics:

- [OMSU dimensions](#)
-

OMSU dimensions

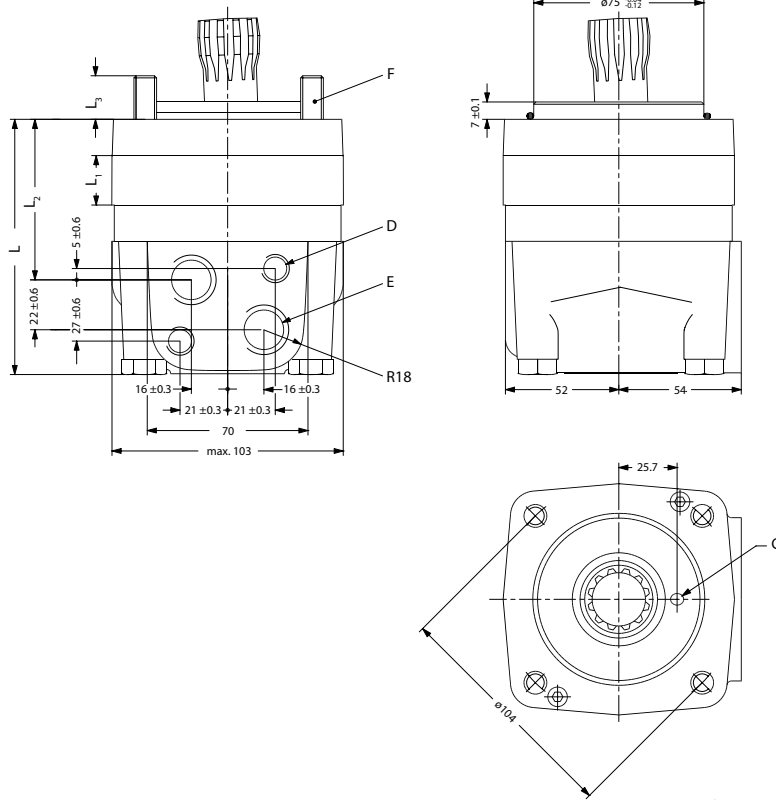

A151-1826.11

- C:** Drain hole $\phi 5 +0.2 -0.1$
- D:** M10; 11 mm deep
- E:** G 1/2; 15 mm deep

	L_{max}	L_1	L_2	L_3
OMSU 80	105	14.0	63	22.0
OMSU 100	109	17.4	67	18.6
OMSU 125	113	21.8	71	14.2
OMSU 160	119	27.8	77	18.2
OMSU 200	126	34.8	84	21.2
OMSU 250	135	43.5	93	22.5

Chapter 3

Connection dimensions, attached component

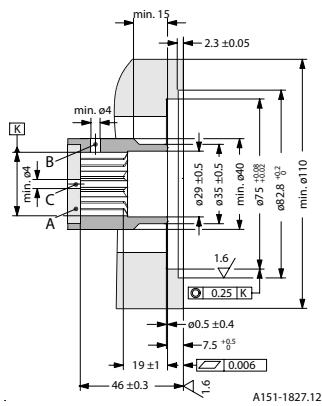

A: Hardened stop plate
B or C: oil circulation holes

Chapter

4

Internal spline data for the component to be attached

Topics:

- *Material:*
- *Hardening specification:*

The attached component must have internal splines corresponding to the external splines on the motor cardan shaft (see drawing below).

Material:

Case hardening steel with a tensile strength corresponding at least to 20 MoCr4 (900 N/mm²).

See also SAE 8620 for further information on steel material.

Hardening specification:

- On the surface: HV = 750 ±50
- 7 ±2 mm under the surface: HV = 560

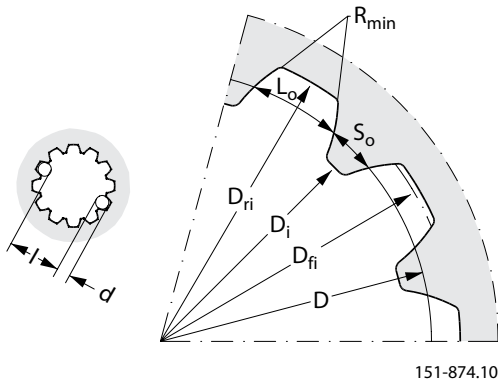

*Finished dimensions (when hardened)

Internal involute spline data
Standard ANS B92. 1-1970, class 5
(corrected $m \cdot x = 0.8$; $m = 2.1166$)

Table 3:

Fillet root side fit		mm [in]
Number of teeth	z	12
Pitch	DP	12/24
Pressure angle	D	30°
Pitch dia.		25.4 [1.0]
Major dia.	D_{ri}	$28.0_{-0.1}^0$ [$1.10_{-0.1}^0$]
Form dia. (min.)	D_{fi}	27.6 [1.09]
Minor dia	D_i	$23.0_{0}^{0.033}$ [$0.9055_{0}^{.0013}$]
Space width (circular)	L_o	4.308 ± 0.020 [0.1696 ± 0.0008]
Tooth thickness (circular)	S_o	2.341 [0.09217]
Fillet radius	$R_{min.}$	0.2 [0.008]
Max. measurement between pins*	l	$17.62_{0}^{+0.15}$ [$0.700_{-0.06}^0$]

Fillet root side fit	mm [in]
Pin dia	d 4.835 ±0.001 [0.1903 ±0.00004]

Chapter

5

General data

Topics:

- *Drain connection on OMSU or attached component*
- *Installing OMSU*
- *Mounting*
- *Direction of rotation*
- *Maximum tightening torque*
- *Checking OMSU*
- *Exploded view OMSU*
- *OMSU spare parts list*

Drain connection on OMSU or attached component

The case pressure is released to the motor return pressure by the motor drain hole (\varnothing 5 mm) and the incorporated check valves.

A drain line ought to be used when pressure in the return line can exceed the permissible pressure on the shaft seal of the attached component.

The drain line can only be connected to the drain connection of the attached component, i.e. the OMSU motor has no external drain connection.

The drain line on the attached component allows oil to flow freely between component and the motor.

The drain line must be led to the tank in such a way that there is no risk of the motor and attached component being drained of oil during operational stop.

The maximum pressure in the drain line is limited by the attached component and its shaft seal.

Installing OMSU

To ensure that the splines connection of the cardan shaft receive sufficient oil, we recommended a conical sealing between shaft of the attached component and the motor intermediate plate as well as an oil circulation the attached component (see page 3). The conical sealing ring (code no. 633B9023) is supplied with the motor. We further recommend O-ring seal between motor and the counter part. The O-ring (code no. 633B1396) is supplied with the motor.

Mounting

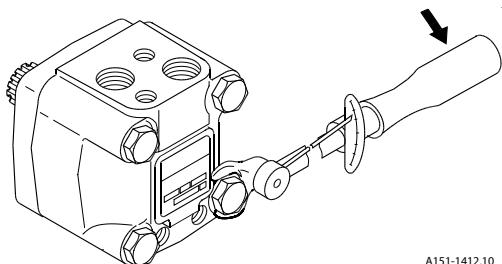

A151-1412.10

Max. tightening torque	
75^{+5}_0 Nm	[660 ⁺⁵⁰ ₀ lbf•in]

Direction of rotation

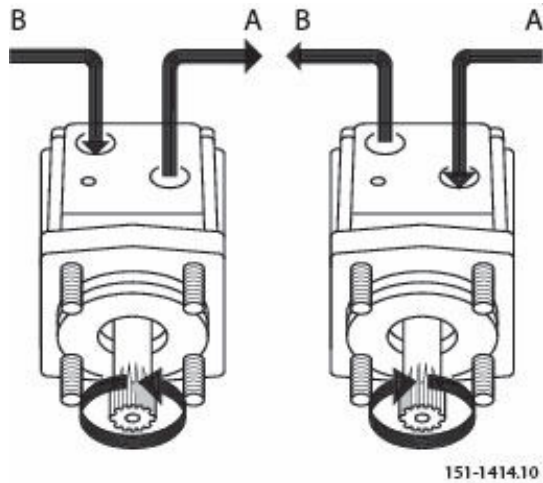

Maximum tightening torque

Maximum tightening torque	
Screwed connection	G 1/2 [7/8-14 UNF]
with steel washer	130 N•m [1150 lbf•in]
with aluminium washer	70 N•m [620 lbf•in]
with cutting edge	130 N•m [1150 lbf•in]
with O-ring Boss port	70 N•m [620 lbf•in]

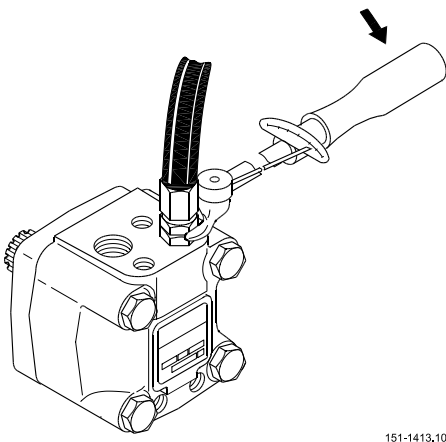

Checking OMSU

In order to make sure that the OMSU counterpart is correct, the drainflow should be measured on the first of each new application. Any subsequent modification of the counterpart should imply new checking. When the motor is fitted

onto the counter part with the correct tightening torque, the drain flow is measured at $Q = 30$ l/min and an oil viscosity of $35 \text{ mm}^2/\text{s}$ at differential pressure:

Motor	Differential pressure
OMSU 80 - 160	140 bar
OMSU 200	110 bar
OMSU 250	90 bar
OMSU 315	70 bar
OMSU 400	55 bar

After minimum 5 min. of operation the drainflow shall be minimum 0.03 l/min and maximum 1.00 l/min at maximum pressure of bar 6 in the drain line during testing.

Exploded view OMSU

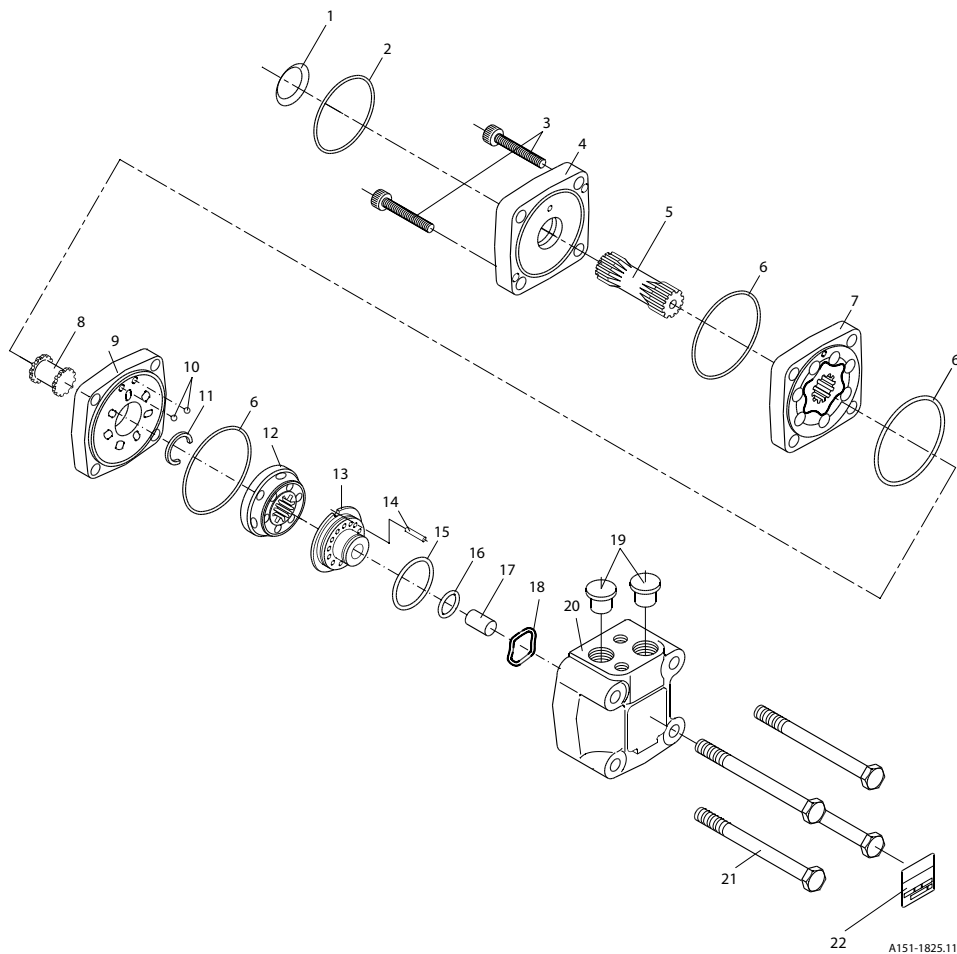

Table 4: Tightening torque

Item 21:	75 - 80 Nm [660 - 705 lbf•in]
----------	-------------------------------

OMSU spare parts list

Table 5: OMSU spare parts list

Item	Spare parts		Code number	Number per motor
1	Seal ring		633B9023	1
2	O-ring	74 x 3 mm NBR ISO 1629	633B1396	1
3	Screw M5			
	OMSU 80	L = 45 mm	681X1512	2
	OMSU 100	L = 50 mm	681X1702	2
	OMSU 125	L = 55 mm	681X9282	2
	OMSU 160	L = 60 mm	681X1703	2
	OMSU 200	L = 70 mm	681X0354	2
	OMSU 250	L = 80 mm	681X0568	2
4	Intermediate plate		151F1717	1
5	Cardan shaft			
	OMSU 80	l = 70 mm	11075495	1
	OMSU 100	l = 73 mm	11077519	1
	OMSU 125	l = 78 mm	11077838	1
	OMSU 160	l = 84 mm	11075528	1
	OMSU 200	l = 91 mm	11077921	1
	OMSU 250	l = 99.5 mm	11077919	1
6	O-ring	82.5 x 2 mm NBR ISO R 1629	633B1431	3

Item	Spare parts		Code number	Number per motor	
7	Gearwheel set				
	OMSU 80	w = 14 mm	151F1091	1	
	OMSU 100	w = 17 mm	151F1092	1	
	OMSU 125	w = 22 mm	151F1093	1	
	OMSU 160	w = 28 mm	151F1094	1	
	OMSU 200	w = 35 mm	151F1095	1	
	OMSU 250	w = 44 mm	151F1096	1	
8	Valve drive		11030924	1	
9	Channel plate		151F1822	1	
10	Check valve ball	ø 3/16 in	689X1005	2	
11	Stop ring (only OMSU 200, 250, 315 and 400)		151F1542	1	
12	Disc valve		151F1022	1	
13	Balance plate		151F1738	1	
14	Guide pin	ø 4 mm	l = 20 mm DIN 1481	682L9105	1
15	O-ring 45 x 2 mm				
	NBR, ISO R 1629		633B1429	1	
	FPM, ISO R 1629		633B1455	1	
16	O-ring 24 x 2 mm				
	NBR, ISO R 1629		633B1428	1	
	FPM, ISO R 1629		633B1453	1	
17	Spacer		151F1449	1	
18	Spring washer		684X0097	1	
19	Seal plug G 1/2		633X0074	2	
20	Valve housing		151F1803	1	

Item	Spare parts		Code number	Number per motor
21	Screw M10			
	OMSU 80, 100, 125	1 = 120 mm	681X1349	4
	OMSU 160	1 = 130 mm	681X1350	4
	OMSU 200	1 = 140 mm	681X1352	4
	OMSU 250	1 = 150 mm	681X1353	4
22	Name plate			
A	Set of seals items 1, 6, 15, 16		151F0103	
B	Set of seals items 1, 2		151F1020	
NBR: (Buna N, Perbunan); FPM (Viton)				

