

Technical Information

PLUS+1[®] Mobile Machine Displays

DP570 Series



Revision history

Table of revisions

| Date | Changed | Rev |
|---------------|---|------------|
| January 2017 | Added topic: High range input impedance for analog inputs | 0701 |
| November 2016 | Minor update | 0604 |
| March 2016 | Corrected literature number | 0603 |
| March 2016 | Updated to Engineering Tomorrow design | 0602 |
| February 2016 | DP570 overview text changes; Linux® operating system text changes | 0601 |
| July 2015 | Vault memory, removed reference to USB port (DP570 does not have one) | FB |
| March 2015 | Various | FA |
| February 2015 | Converted to Danfoss layout; Ingress Protection (IP) rating updated; new drawing with updated bracket and seal for flush mounted option | EA |
| December 2013 | Model feature | DA |
| November 2013 | Screw lengths and torque | CA |
| November 2013 | Operating temperature | BA |
| November 2013 | First edition | AA |

Contents

Literature references

DP570 reference literature.....4

User liability and safety statements

OEM responsibility..... 5

Overview

DP570 Series Displays.....6
 PLUS+1® GUIDE.....6
 Linux® operating system.....6

Ordering information

Product naming convention..... 7
 Related products.....8

Inputs/outputs

Inputs.....9
 Digital/Analog/CAN.....9
 Digital/Analog/4-20mA.....9
 High range input impedance for analog inputs..... 11
 Multifunction.....12
 Encoder.....14
 Video.....14
 Outputs.....14
 Video power output.....14

Controller Area Network (CAN) specifications

CAN shield/analog inputs.....15
 CAN communication.....15

Memory

NV memory.....16
 FRAM Memory.....16
 Vault Memory.....16

Product ratings

Electrical.....17
 Environmental.....17
 Testing criteria.....17

Maintenance guidelines

LCD module19

Installation

Dimensions.....20
 Two mounting options.....21
 Flush mounted.....21
 Stand-alone on post.....21
 Pin assignments.....22
 Machine wiring guidelines.....23
 Machine welding guidelines.....23

Literature references

DP570 reference literature

| Literature title | Literature type | Literature number |
|---|-----------------------|-------------------|
| <i>DP570 Series PLUS+1® Mobile Machine Displays</i> | Technical Information | L1328765 |
| <i>DP570 Series PLUS+1® Mobile Machine Displays</i> | Data Sheet | L1317788 |
| <i>PLUS+1® GUIDE Software User Manual</i> | Operation Manual | 10100824 |

Technical Information (TI)

A TI is comprehensive information for engineering and service personnel to reference.

Data Sheet (DS)

A DS is summarized information and parameters that are unique to a specific model.

API Specifications (API)

An API is specifications for programming variable settings.

[API specifications are the definitive source of information regarding pin characteristics.](#)

PLUS+1® GUIDE User Manual

This user operation manual (OM) details information regarding the PLUS+1® GUIDE tool set that is used to build PLUS+1® applications. This OM covers the following broad topics:

- How to use the GUIDE graphical application development tool to create machine applications
- How to configure module input and output parameters
- How to configure module input and output parameters
- How to download GUIDE applications to target PLUS+1® hardware modules
- How to upload and download tuning parameters
- How to use the PLUS+1® Service Tool

Latest version of technical literature

Danfoss product literature is online at: <http://powersolutions.danfoss.com/literature/>

User liability and safety statements

OEM responsibility

The OEM of a machine or vehicle in which Danfoss products are installed has the full responsibility for all consequences that might occur. Danfoss has no responsibility for any consequences, direct or indirect, caused by failures or malfunctions.

- Danfoss has no responsibility for any accidents caused by incorrectly mounted or maintained equipment.
- Danfoss does not assume any responsibility for Danfoss products being incorrectly applied or the system being programmed in a manner that jeopardizes safety.
- All safety critical systems shall include an emergency stop to switch off the main supply voltage for the outputs of the electronic control system. All safety critical components shall be installed in such a way that the main supply voltage can be switched off at any time. The emergency stop must be easily accessible to the operator.

Overview

PLUS+1[®] Mobile Machine Displays are designed to provide flexible, expandable, powerful and cost effective total machine management system displays for a wide variety of vehicle applications.

DP570 Series Displays

DP570 Series Displays are designed to perform in the most extreme mobile machine environments. The latest technology with backlight provides outstanding brightness and contrast performance resulting in an easy-to-read screen. Develop your own software and layout using the PLUS+1[®] GUIDE (Graphical User Integrated Development Environment) and the GUIDE Vector Based Screen Editor (VBSE). A basic graphic library is available.

PLUS+1[®] GUIDE

PLUS+1[®] GUIDE (Graphical User Integrated Development Environment) is a complete toolbox that generates downloadable applications for all programmable PLUS+1[®] Compliant products.

A screen editor allows easy development of applications by programmers without formal software development training. The expertise from a software engineer is not needed to find your way around in PLUS+1[®] GUIDE

Linux[®] operating system

DP570 Series Displays contain embedded Linux[®] operating system software that is copyrighted software licensed under the GPL Version 2.0 or LGPL Version 2.1.

Linux[®] operating system software is free software; you can redistribute it and/or modify it under the terms of the GNU General Public License as published by the Free Software Foundation; Licenses full notice available:

GPL Version 2.0 <http://www.gnu.org/licenses/old-licenses/gpl-2.0.html>

LGPL Version 2.1 <http://www.gnu.org/licenses/old-licenses/lgpl-2.1.html>

As an installer of Linux[®] operating system you will have your own obligations under the licensing agreements, which may include among other things the obligation to include a copy of these licenses or to include an offer of a physical copy of the source code for such software with your distributions of the equipment. You should carefully review the licenses to determine what your obligations and options may be for your intended use.

Anyone in receipt of this program may obtain the complete corresponding source code from Danfoss for a period of three years after the last shipment of this product and/or spare parts by going on line at <http://www.danfoss.com> or include "source code for DP570" in your written request to:

PLUS+1[®] Helpdesk Danfoss (US) Company, 3500 Annapolis Lane North Plymouth, MN 55447 USA

Ordering information

Product naming convention

DP570 model code

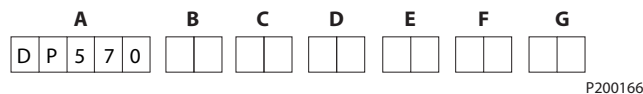

This is not a variant configurator.

Product configuration model code

| A | B | C | D | E | F | G | Part number |
|-------|----|----|----|----|----|----|-------------|
| DP570 | 01 | 00 | 00 | 00 | 00 | 01 | 11134525 |
| DP570 | 01 | 00 | 00 | 00 | 01 | 01 | 11130432 |
| DP570 | 01 | 00 | 00 | 00 | 00 | 00 | 11140997 |
| DP570 | 01 | 00 | 00 | 00 | 01 | 00 | 11140996 |

A—Model name

| Code | Description |
|-------|---------------------------------|
| DP570 | PLUS+1® Mobile Machine Displays |

B—Input/output options

| Code | Description |
|------|--|
| 01 | User configurable: 1 CAN, 2 DIN/AIN, 2 DIN/AIN/4-20 mA, 2 Multi-function, 1 DOUT or 2 CAN, 2 DIN/AIN/4-20 mA, 2 Multi-function, 1 DOUT |

C—Real time clock

| Code | Description |
|------|-------------|
| 00 | RTC |

D—Flash memory/application key

| Code | Description |
|------|--------------------------------|
| 00 | 512 MB/without application key |

E—Application log (vault memory)

| Code | Description |
|------|-------------|
| 00 | 16 MB |

F—Video input options

| Code | Description |
|------|-----------------|
| 00 | None |
| 01 | One video input |

Ordering information

G—Mounting options

| Code | Description |
|------|----------------|
| 00 | Post mounting |
| 01 | Panel mounting |

Related products

Mating connector kit contents

| Description | Part numbers |
|--|--------------|
| M12 5 pin male connector | 11130712 |
| DEUTSCH terminal | 10100743 |
| 16 to 22 AWG crimp tool | 10100744 |
| 20 AWG crimp tool | 10100745 |
| 12 pin DEUTSCH WM 125 locking plug | 10100741 |
| DEUTSCH DTM06-12SA 12 pin connector kit (16 to 22 AWG) | 10102025 |
| DEUTSCH DTM06-12SA 12 pin connector kit (20 AWG) | 10100944 |
| Connection-kit DP570 with camera cable | 11145163 |

Accessories

| Description | Part numbers |
|--|---|
| Panel mounting kit | 11140430 |
| PLUS+1® GUIDE Professional Software (Includes 1 year of software updates, a single user license, Service and Diagnostic Tool and Screen Editor) | 11179523 (annual renewal with 11179524 to keep the software updates) |
| Post mounting kit | 11144122 |

Inputs/outputs

Inputs

DP570 Series Displays support the following pin types:

- Digital or Analog (DIN/AIN)
- Digital, Analog, or 4–20 mA (DIN/AIN/4–20 mA)
- Multifunction (DIN/AIN/FreqIN, Rheo, 4–20 mA)

DP570 Series Displays have input pins that support multiple functions. Pins that support multiple input types are user-configurable using PLUS+1® GUIDE software.

Digital/Analog/CAN

Normal range multifunction input

| Description | Unit | Minimum | Maximum | Comment |
|-----------------------------------|------|------------|---------|----------|
| Range | V | 0 | 5.88 | — |
| Resolution | mV | 2.14 | | — |
| Worst case error | mV | 130 | | — |
| Input impedance | kΩ | 233 ± 3 | | To 0 V |
| Input impedance with pull-down | kΩ | 14.1 ± 0.2 | | To 0 V |
| Input impedance with pull-up | kΩ | 14.1 ± 0.2 | | To 5 V |
| Input impedance with pull-up/down | kΩ | 7.3 ± 0.1 | | To 2.5 V |

High range multifunction input

| Description | Unit | Minimum | Maximum | Comment |
|-----------------------------------|------|------------|---------|----------|
| Range | mV | 0 | 37.296 | — |
| Resolution | mV | 14.3 | | — |
| Worst case error | V | 1.296 | | — |
| Input impedance | kΩ | 110 ± 2 | | To 0 V |
| Input impedance with pull-down | kΩ | 13.2 ± 0.2 | | To 0 V |
| Input impedance with pull-up | kΩ | 13.2 ± 0.2 | | To 5 V |
| Input impedance with pull-up/down | kΩ | 7 ± 0.1 | | To 2.5 V |

Digital/Analog/4-20mA

Normal range multifunction input

| Description | Unit | Minimum | Maximum | Comment |
|-----------------------------------|------|------------|---------|--|
| Range | V | 0 | 5.88 | — |
| Resolution | mV | 2.14 | | — |
| Worst case error | mV | 130 | | Over the full temperature range -30° C to +60° C (-22° F to +140° F) |
| Input impedance | kΩ | 233 ± 3 | | No pull up or pull down |
| Input impedance with pull-down | kΩ | 14.1 ± 0.2 | | Pull down to ground |
| Input impedance with pull-up | kΩ | 14.1 ± 0.2 | | Pull up to +5 V |
| Input impedance with pull-up/down | kΩ | 7.3 ± 0.1 | | Pull up to +2.5 V |

Inputs/outputs

Current input

| Description | Unit | Minimum | Maximum | Comment |
|------------------|------|--------------|---------|--|
| Range | mA | 0 | 5.43 | — |
| Resolution | μA | 21 | | — |
| Worst case error | mA | 1.7 | | Over the full temperature range -30° C to +60° C (-22° F to +140° F) |
| Input impedance | Ω | 100.76 ± 0.1 | | — |

Inputs/outputs

High range input impedance for analog inputs

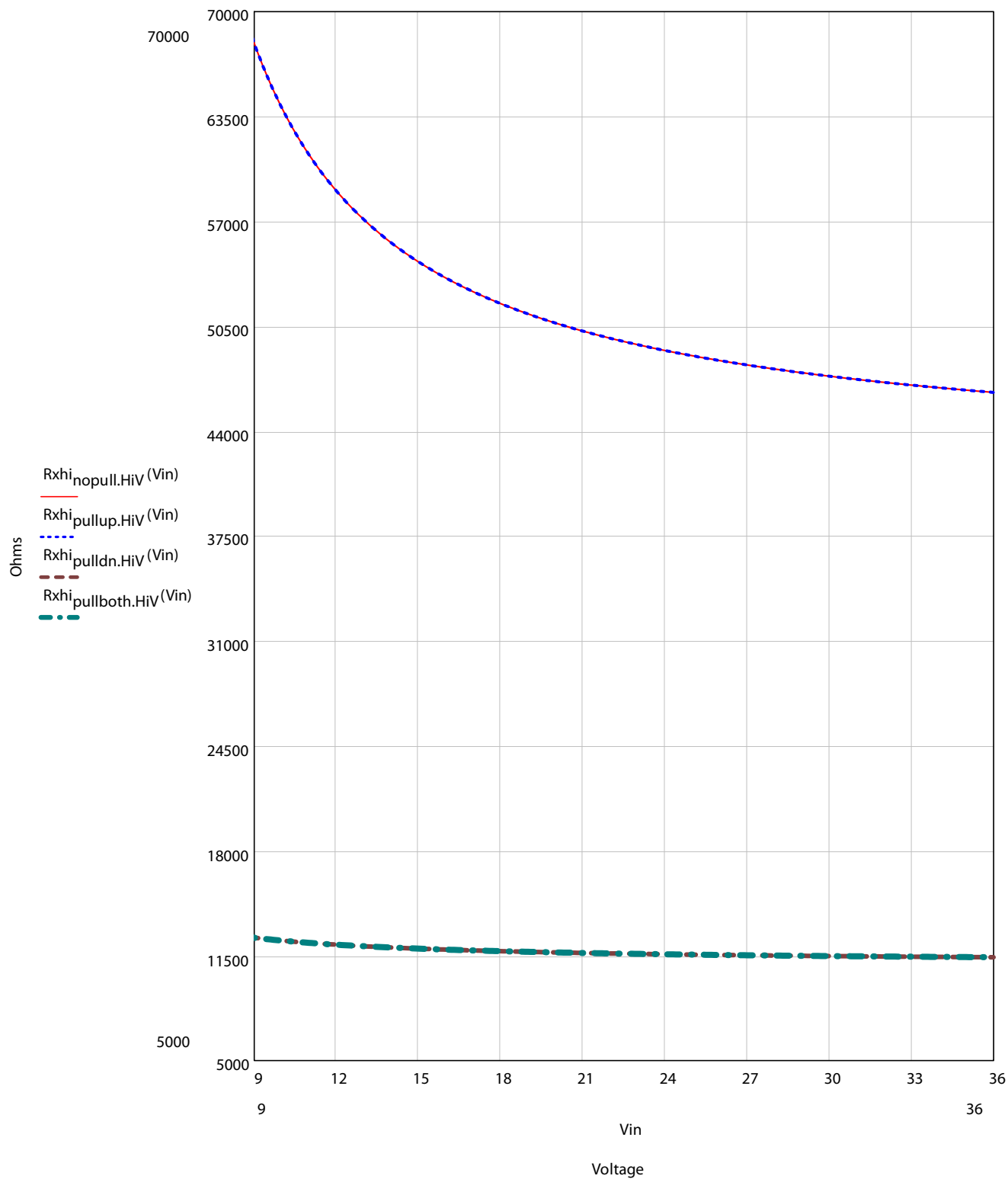

Inputs/outputs

Multifunction

Low range frequency input PPU

| Description | Minimum | Typical | Maximum | Comment |
|-----------------------------|---------|---------|----------|--|
| Minimum discernible voltage | 0 mV | — | 12.9 mV | — |
| Maximum discernible voltage | 377 mV | 404 mV | 431 mV | — |
| Precision | — | — | 0.149 mV | — |
| Worst case error | — | — | 27 mV | Over the full temperature range -30° C to +60° C (-22° F to +140° F) |
| Rising voltage threshold | 0.11 V | — | 0.30 V | Voltage required for frequency input to read high |
| Falling voltage threshold | 0.04 V | — | 0.22 V | Voltage required for frequency input to read low |
| Input impedance | 230 kΩ | 233 kΩ | 236 kΩ | No pull up or pull down |
| Input impedance | 13.9 kΩ | 14.1 kΩ | 14.3 kΩ | Pull up to +5V or pull down to ground |
| Input impedance | 7.2 kΩ | 7.3 kΩ | 7.4 kΩ | Pull to +2.5V |

Middle range frequency input PPU

| Description | Minimum | Typical | Maximum | Comment |
|-----------------------------|---------|---------|---------|--|
| Minimum discernible voltage | 0 mV | — | 20 mV | — |
| Maximum discernible voltage | 5.62 V | 5.75 V | 5.88 V | — |
| Precision | — | — | 2.14 mV | — |
| Worst case error | — | — | 130 mV | Over the full temperature range -30° C to +60° C (-22° F to +140° F) |
| Rising voltage threshold | 0.178 V | — | 3.92 V | Voltage required for frequency input to read high |
| Falling voltage threshold | 0.84 V | — | 2.79 V | Voltage required for frequency input to read low |
| Input impedance | 230 kΩ | 233 kΩ | 236 kΩ | No pull up or pull down |
| Input impedance | 13.9 kΩ | 14.1 kΩ | 14.3 kΩ | Pull up to +5V or pull down to ground |
| Input impedance | 7.2 kΩ | 7.3 kΩ | 7.4 kΩ | Pull to +2.5V |

High range frequency input PPU

| Description | Minimum | Typical | Maximum | Comment |
|-----------------------------|----------|---------|----------|---------|
| Minimum discernible voltage | 0 mV | — | 130 mV | — |
| Maximum discernible voltage | 34.704 V | 36 V | 37.296 V | — |
| Precision | — | — | 14.3 mV | — |

Inputs/outputs

High range frequency input PPU (continued)

| Description | Minimum | Typical | Maximum | Comment |
|---------------------------|---------|---------|----------|--|
| Worst case error | — | — | 1.296 mV | Over the full temperature range -30° C to +60° C (-22° F to +140° F) |
| Rising voltage threshold | 11.83 V | — | 26.55 V | Voltage required for frequency input to read high |
| Falling voltage threshold | 5.61 V | — | 18.89 V | Voltage required for frequency input to read low |
| Input impedance | 108 kΩ | 110 kΩ | 112 kΩ | No pull up or pull down |
| Input impedance | 13.0 kΩ | 13.2 kΩ | 13.4 kΩ | Pull up to +5V or pull down to ground |
| Input impedance | 6.9 kΩ | 7 kΩ | 7.1 kΩ | Pull to +2.5V |

Resistance input

| Description | Unit | Minimum | Maximum | Comment |
|----------------|------|---------|---------|---------|
| Range | Ω | 0 | 10000 | — |
| Resolution | — | — | — | — |
| Source current | mA | 0 | 3.6* | — |

* When configured as a resistance/rheostat/temp sensor input, the device will provide up to 3.76 mA current to an external load which can then be measured. The equation for calculating AD counts for a given load is: AD counts = $(2338 * RL / (RL + 1330))$.

Rheostat inputs: AD counts and load relationship

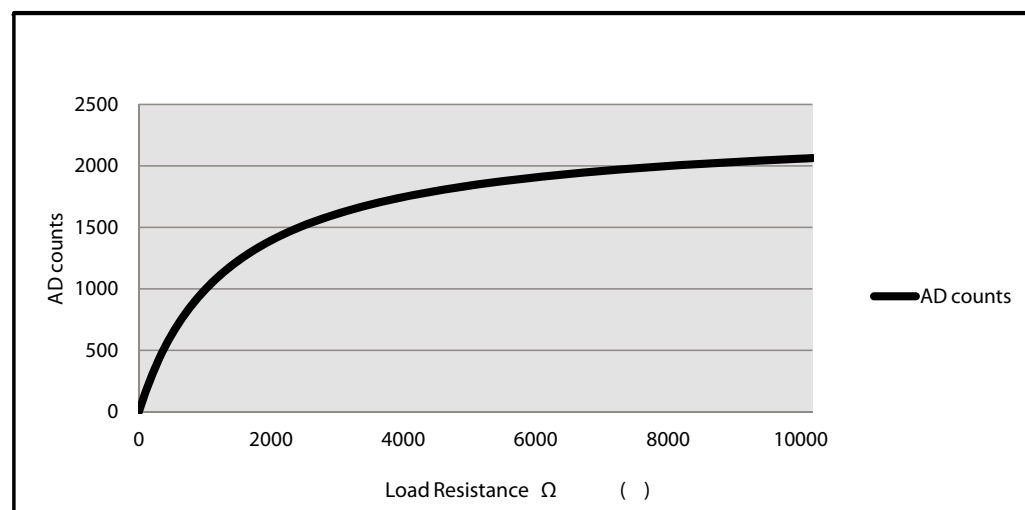

P200167

4–20 mA input

| Description | Unit | Minimum | Maximum | Comment |
|-------------|------|---------|---------|---------|
| Range | mA | 0 | 54.3 | — |
| Resolution | μA | 21 | | — |

Inputs/outputs

4–20 mA input (continued)

| Description | Unit | Minimum | Maximum | Comment |
|------------------------------|------|------------|---------|--|
| Worst case error | mA | 1.7 | | Over the full temperature range -30° C to +60° C (-22° F to +140° F) |
| Input impedance | Ω | 100.76 ± 2 | | — |
| Maximum over-current voltage | V | 5.43 | | — |

Warning

Using these inputs can affect the accuracy of any Safety Critical closed loop control. These displays do not have a Real Time Operating System (RTOS). Do not use these displays as the master control for any type of safety critical control, or closed loop control system. Frequency inputs are managed by the operating system. Accuracy can be affected by processor load. These displays should only be used for non-safety critical related functions.

Encoder

The encoder input is only suitable for user interface functions, such as, navigating in menus and adjusting values because there is no guarantee that all pulses are detected and the detected direction can be false. The rate of pulses should be kept at a few tens per second to minimize the loss of detected position changes.

The encoder function samples the A and B signals from the encoder and increments or decrements the counter according to the phase sequence. The counter is incremented/decremented on every low to high and high to low edge of the A signal. Some encoders with detents give a complete pulse between detents and the counter will be incremented/decremented by two for every detent. The counter is incremented when the A signal is the leading phase and decremented in the opposite case.

Video

There is one video input, which can accept either NTSC or PAL video signals.

Outputs

Video power output

| Description | Unit | Minimum | Maximum | Typical | Comment |
|----------------------------|------|---------|---------|---------|---------|
| 12V | V | 11.58 | 12.42 | 12 | — |
| Video camera power current | mA | 0 | 400 | — | — |
| Short circuit protection | V | — | 36 | — | — |

To power the camera up, it is recommended to use the display as power supply. If using a different power supply, it should meet the specification of the camera in regards of the voltage type and range, the current and voltage amount it can supply to its load, stability of the output voltage and current under varying line and load conditions, operating/storage temperature ranges.

The use of a different power supply for the camera can create “noise” on the signal line which will affect its functionality.

Controller Area Network (CAN) specifications

CAN shield/analog inputs

The CAN shield pin on the unit can be used as a non-configurable analog input.

The values in the following table assumes that software compensates for errors in the analog to digital (A/D) converter.

CAN shield

| Description | Unit | Minimum | Maximum | Typical | Comment |
|-----------------|------|---------|---------|---------------------------|---------|
| Input impedance | — | — | — | 0.68 μ F + 1 Ω | — |

Analog input (5 V only)

| Description | Unit | Minimum | Maximum | Comment |
|------------------------|------------|-------------------------|---------|---------|
| Allowed voltage at pin | V | 0 | 36 | — |
| Measuring range | V | 0 | 5.75 | — |
| Resolution | mV | 1.4 | | — |
| Worst case error | mV | $\pm(20 + U \cdot 2\%)$ | | — |
| Input impedance | k Ω | 233 \pm 3 | | — |

CAN communication

There are two stand-alone CAN-busses. Both CAN ports are software configurable and can be used for PLUS+1[®] communication. One of them can be used either as CAN or a digital-analog input.

CAN communication

| Description | Unit | Minimum | Maximum | Comment |
|-----------------------------|------|---------|---------|-----------------------------------|
| Available baud rates | kBd | 50 | 1000 | The default baud rate is 250kbit. |
| Maximum input voltage range | V | 0 | 36 | — |

Memory

NV memory

 **Caution**

Non-volatile (NV) memory data loss is possible when the NV write cycle is not fully completed. When downloading a new application ensure data is not being written to NV memory.

FRAM Memory

DP570 Series Displays use Ferroelectric Random Access Memory (FRAM). FRAM has a write endurance of over 100 trillion cycles, which is ideal for datalogging. 2kB is available for application.

Vault Memory

DP570 Series Displays have 16 MB of flash vault memory (application logging memory). Application developers use this memory to log machine event data then use the PLUS+1[®] Service Tool to extract the logged data.

Accessing non-volatile or application log memory can delay the service tool scan.

Product ratings

Electrical

Supply voltage

| Description | Unit | Minimum | Maximum | Comment |
|---|------|---------|---------|----------------------------------|
| DC supply voltage | V | 9 | 36 | With reverse polarity protection |
| DC supply current (circuit board only) | A | 0 | — | UBat = 12 V |
| | | 0 | — | UBat = 24 V |
| Power supply interruption (without rebooting) | ms | — | — | 200 ms |

Warning

Output pins produce high voltage. High voltage can cause fire and/or electrical shock, if flammable gasses or chemicals are present, can cause an explosion. To protect against product damage and possible injury, do not exceed power supply voltage ratings and do not store this product where flammable gasses or chemicals are present.

Environmental

General

| Description | Units | Minimum | Maximum | Comment |
|--------------------------------|---------|-----------|------------|--|
| Operating temperature | °C [°F] | -20 [-4] | +60 [+140] | — |
| Storage temperature | °C [°F] | -30 [-22] | +80 [+176] | — |
| Ingress Protection (IP) rating | IP67 | | | With mating connector installed and sealing plugs in unused connections. |

Warning

Excessive high/low operating/storage temperatures can damage electronics. Damaged electronics can result in performance failure. To protect against product damage and possible injury, do not operate/store product in a environment that exceeds specified temperature ratings.

Testing criteria

Climatic

| Condition | Rating |
|---------------------------------|------------------------------|
| Cold/heat storage and operation | IEC 60068-2-1, IEC 60068-2-2 |
| Temperature change | IEC 60068-2-14 |
| Moisture ingress | IEC 60529 |
| Sunlight radiation | ISO 16750-4 |
| Temp humidity voltage | IEC 60068-2-38 |

Mechanical

| Condition | Rating |
|----------------------|----------------|
| Vibration, resonance | IEC 60068-2-6 |
| Vibration, operation | IEC 60068-2-64 |

Product ratings

Mechanical (continued)

| Condition | Rating |
|------------------|----------------|
| Bump | IEC 60068-2-29 |
| Shock | IEC 60068-2-27 |
| Free fall | IEC 60068-2-32 |

Maintenance guidelines

Opening the display's housing voids the factory warranty.

LCD module

 **Caution**

Prolonged exposure to direct intense sunlight can cause premature failure of the LCD module. This risk can be reduced by providing shading or mounting the display at an incline rather than the horizontal.

 **Caution**

The protective glass will break if hit with a hard or heavy object. If the protective glass is broken, remove the display from your machine then return the display to Danfoss to be serviced.

Clean the display's housing and protective glass with a clean, soft, damp cloth, or mild dishwashing detergent because abrasive pads or solvents, including alcohol, benzene, and paint thinner can cause scratching and discoloration.

Installation

Dimensions

DP570 dimensions in millimeters

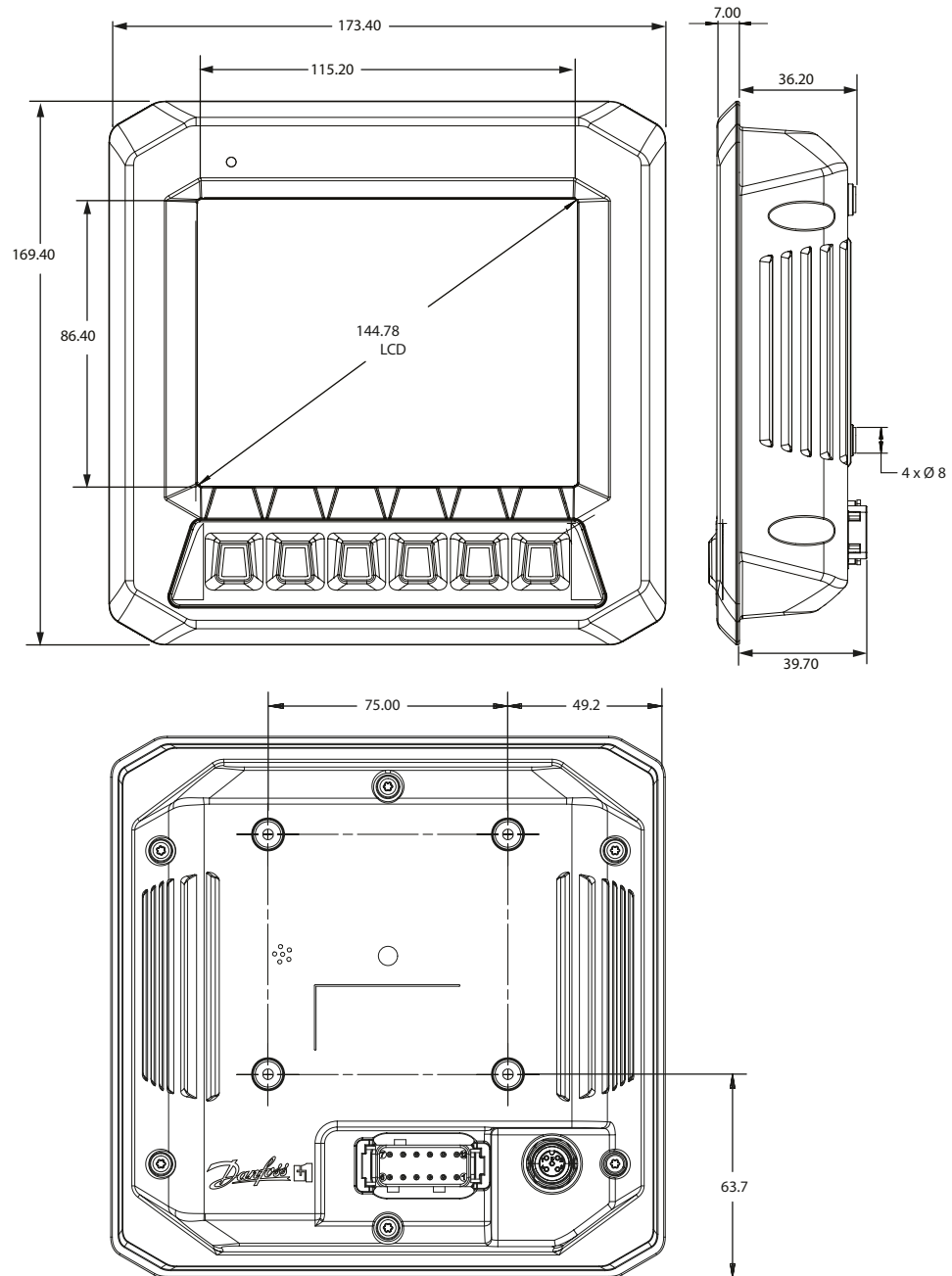

kwa1422303242511

Installation

Two mounting options

Flush mounted

DP570 panel cutout and mounting kit in milimeters

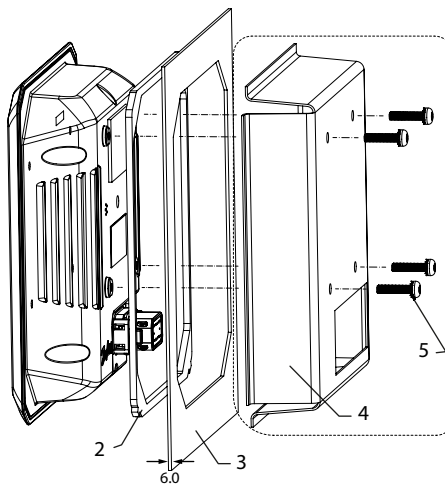
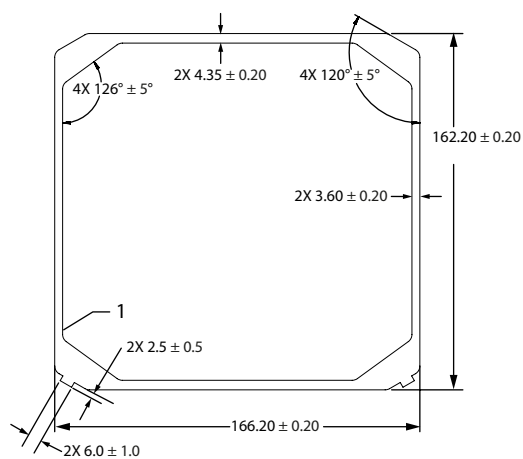

kwa1422304499473

1. 16X R (4)
2. Panel seal is part of the panel mount kit
3. Mounting panel: 6.00 mm maximum thickness
4. Panel bracket
5. M4X10 screws with lock washers (4X)

Stand-alone on post

Post mounting option in millimeters

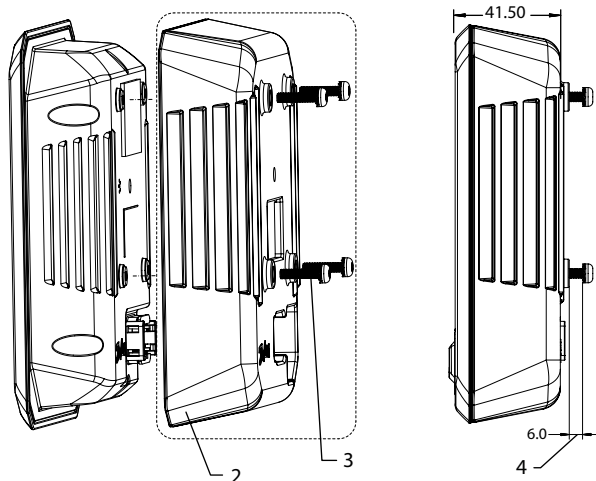
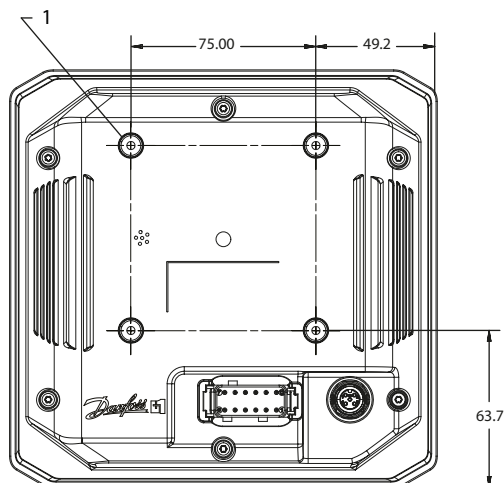

kwa1422368364473

1. 4X insert for M4 screw x 0.7 thread x 11 maximum depth
2. Post mount cover
3. M4X18 screws with Post mount cover lock washers (4X)
4. Maximum bracket thickness using screws provided with cover

Installation

Pin assignments

DP570 pin assignments

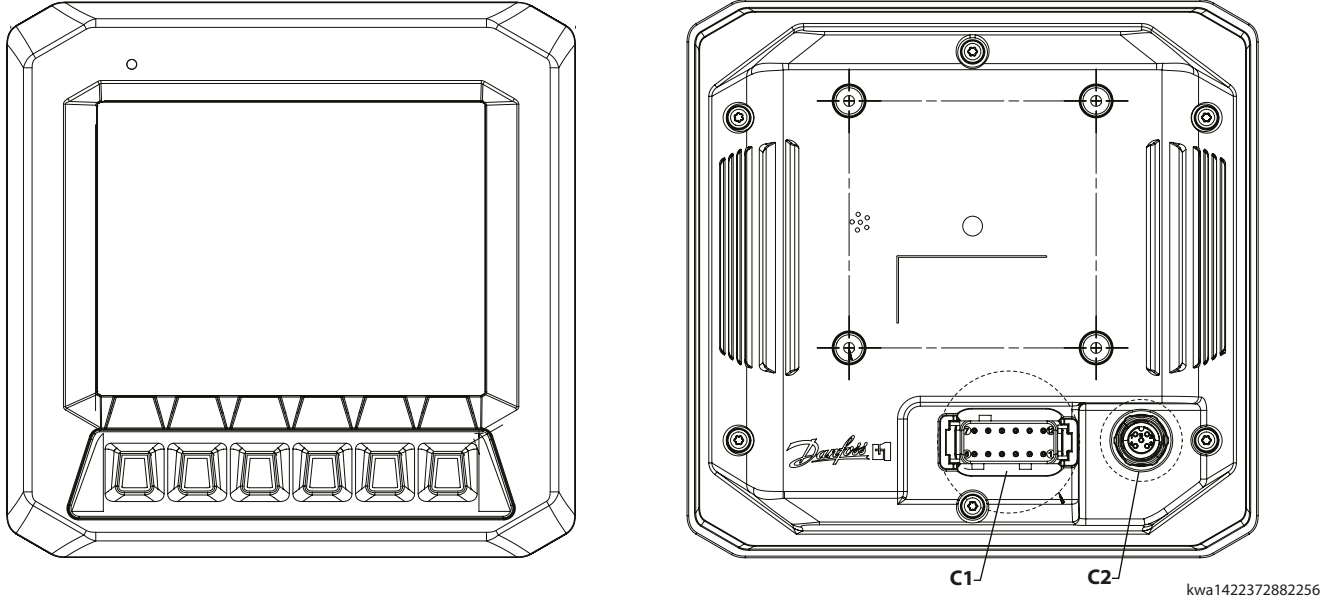

kwa1422372882256

Pin connectors

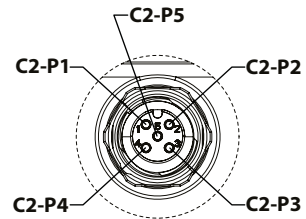
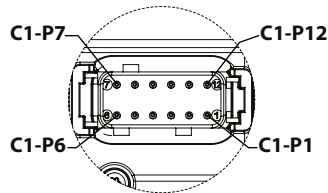

kwa1427484568455

| DEUTSCH DTM06 12-pin | Phoenix M12 5-pin | | |
|----------------------|------------------------|--------|----------------------|
| C1 pin | Function | C2 pin | Function |
| C1-P1 | Power Ground - | C2-P1 | Video Power Ground |
| C1-P2 | Power Input + | C2-P2 | Video Power Supply |
| C1-P3 | CAN0 High + | C2-P3 | Video Signal Input 1 |
| C1-P4 | CAN0 Low - | C2-P4 | Video Signal Ground |
| C1-P5 | CAN Shield | C2-P5 | NC |
| C1-P6 | CAN1 High + or DIN/AIN | | |
| C1-P7 | CAN1 Low - or DIN/AIN | | |
| C1-P8 | DIN/AIN/4-20 mA | | |
| C1-P9 | DIN/AIN/4-20 mA | | |
| C1-P10 | Multi-function Input | | |
| C1-P11 | Multi-function Input | | |
| C1-P12 | DOU | | |

Installation

Machine wiring guidelines

- Protect wires from mechanical abuse, run wires in flexible metal or plastic conduits.
- Use 85° C (185° F) wire with abrasion resistant insulation and 105° C (221° F) wire should be considered near hot surfaces.
- Use a wire size that is appropriate for the module connector.
- Separate high current wires such as solenoids, lights, alternators or fuel pumps from sensor and other noise-sensitive input wires.
- Run wires along the inside of, or close to, metal machine surfaces where possible, this simulates a shield which will minimize the effects of EMI/RFI radiation.
- Do not run wires near sharp metal corners, consider running wires through a grommet when rounding a corner.
- Do not run wires near hot machine members.
- Provide strain relief for all wires.
- Avoid running wires near moving or vibrating components.
- Avoid long, unsupported wire spans.
- Ground electronic modules to a dedicated conductor of sufficient size that is connected to the battery (-).
- Power the sensors and valve drive circuits by their dedicated wired power sources and ground returns.
- Twist sensor lines about one turn every 10 cm (4 in).
- Use wire harness anchors that will allow wires to float with respect to the machine rather than rigid anchors.

 **Caution**

Unused pins on mating connectors may cause intermittent product performance or premature failure. Plug all pins on mating connectors.

 **Warning**

Unintended movement of the machine or mechanism may cause injury to the technician or bystanders. Improperly protected power input lines against over current conditions may cause damage to the hardware. Properly protect all power input lines against over-current conditions.

Machine welding guidelines

 **Warning**

High voltage from power and signal cables may cause fire or electrical shock, and cause an explosion if flammable gasses or chemicals are present. Disconnect all power and signal cables connected to the display before performing any electrical welding on a machine.

The following is recommended when welding on a machine equipped with electronic components:

- Turn the engine off.
- Remove electronic components from the machine before any arc welding.
- Disconnect the negative battery cable from the battery.
- Do not use electrical components to ground the welder.
- Clamp the ground cable for the welder to the component that will be welded as close as possible to the weld.

Products we offer:

- Bent Axis Motors
- Closed Circuit Axial Piston Pumps and Motors
- Displays
- Electrohydraulic Power Steering
- Electrohydraulics
- Hydraulic Power Steering
- Integrated Systems
- Joysticks and Control Handles
- Microcontrollers and Software
- Open Circuit Axial Piston Pumps
- Orbital Motors
- PLUS+1® GUIDE
- Proportional Valves
- Sensors
- Steering
- Transit Mixer Drives

Danfoss Power Solutions is a global manufacturer and supplier of high-quality hydraulic and electronic components. We specialize in providing state-of-the-art technology and solutions that excel in the harsh operating conditions of the mobile off-highway market. Building on our extensive applications expertise, we work closely with our customers to ensure exceptional performance for a broad range of off-highway vehicles.

We help OEMs around the world speed up system development, reduce costs and bring vehicles to market faster.

Danfoss – Your Strongest Partner in Mobile Hydraulics.

Go to www.powersolutions.danfoss.com for further product information.

Wherever off-highway vehicles are at work, so is Danfoss. We offer expert worldwide support for our customers, ensuring the best possible solutions for outstanding performance. And with an extensive network of Global Service Partners, we also provide comprehensive global service for all of our components.

Please contact the Danfoss Power Solution representative nearest you.

Comatrol

www.comatrol.com

Schwarzmueller-Inverter

www.schwarzmueller-inverter.com

Turolla

www.turollaocg.com

Hydro-Gear

www.hydro-gear.com

Daikin-Sauer-Danfoss

www.daikin-sauer-danfoss.com

Local address:

Danfoss Power Solutions (US) Company
2800 East 13th Street
Ames, IA 50010, USA
Phone: +1 515 239 6000

Danfoss Power Solutions GmbH & Co. OHG
Krokamp 35
D-24539 Neumünster, Germany
Phone: +49 4321 871 0

Danfoss Power Solutions ApS
Nordborgvej 81
DK-6430 Nordborg, Denmark
Phone: +45 7488 2222

Danfoss Power Solutions Trading (Shanghai) Co., Ltd.
Building #22, No. 1000 Jin Hai Rd
Jin Qiao, Pudong New District
Shanghai, China 201206
Phone: +86 21 3418 5200

Danfoss can accept no responsibility for possible errors in catalogues, brochures and other printed material. Danfoss reserves the right to alter its products without notice. This also applies to products already on order provided that such alterations can be made without changes being necessary in specifications already agreed. All trademarks in this material are property of the respective companies. Danfoss and the Danfoss logotype are trademarks of Danfoss A/S. All rights reserved.